

Scan for more Information

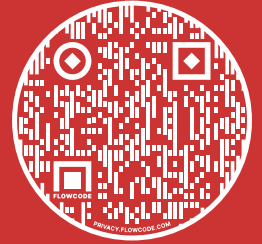

# FANUC

## ROBOCUT *α-CiC* SERIES WIRE EDM



High Speed. High Precision.  
Low Downtime.



## EDM Accuracy, Accelerated

Compared to traditional computer numerical control (CNC) machining, wire electrical discharge machining (EDM) has typically offered superior accuracy at the cost of longer cycle times. FANUC designed the RoboCut to give users the best of both worlds. Cut for hours uninterrupted and machine precision parts with extreme tolerances thanks to the RoboCut's user-friendly interface and resilient design. Every RoboCut model delivers efficient cutting, unmatched accuracy, and legendary longevity.

### Additional Enhancements

- Multiple sensors powered by artificial intelligence ensure stable cutting, regardless of temperature fluctuations
- High-precision taper cutting is made easy with taper adjustment function, including operation screen and jig
- Effortlessly locate precise positions with the workpiece edge-finding function
- Artificial intelligence (AI) technology for easy setup and cutting
- Durable, scratch-resistant, hardened workpiece table

## α-CiC Series

The next generation of the RoboCut has numerous features that allow operators to run machines at greater speeds and produce more precise cuts. The new mechanical structure reduces distortion for exceptional precision cutting. Achieve improved surface finishes without sacrificing cutting speed thanks to the new SF3 power supply, which generates miniaturization and high-frequency discharge pulses.



RoboCut α-C600ic

RoboCut α-C400ic

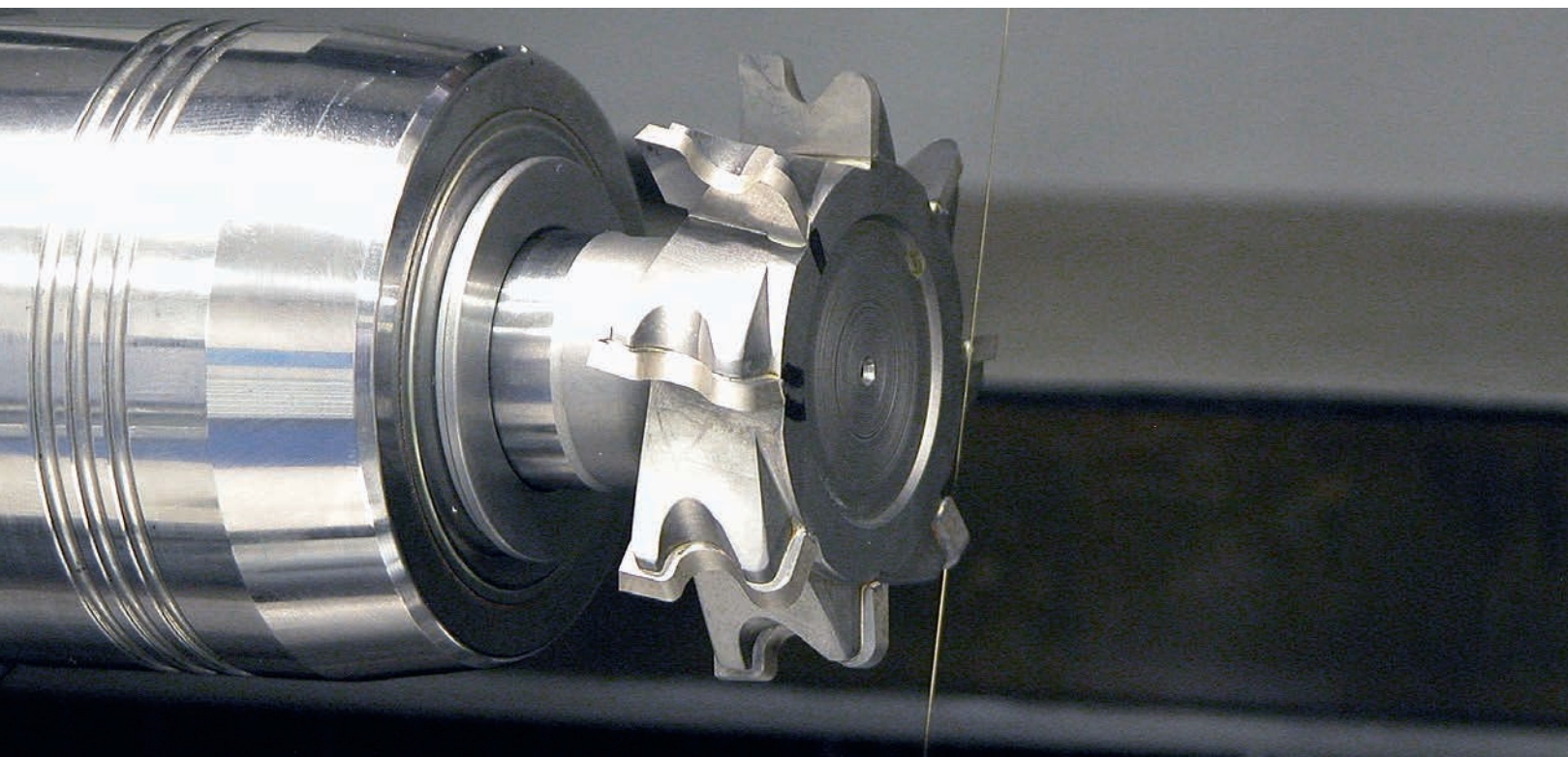

### Still Offering C800iB



#### FEATURES INCLUDE:

- Discharge Control Ai2
- Anti-recast Power Supply
- Automatic Door
- 3D Coordinate System Rotation
- Thermal Monitoring and Compensation
- "Core Stitch" Slug Retention
- Fully Integrated A/B axis for "Turn & Burn" Capability
- Auto Wire Feeding AWF3
- Available with 12" or 20" Z-axis



# Standard Features

- Anti-recast Power Supply
- 3D Coordinate System Rotation
- "Core Stitch" Slug Retention
- Capable of Operating Single and Dual Axis Rotary Tables
- Auto Wire Feeding System (AWF3)
- FANUC 31i-WB Controller with New iHMI User Interface
- Wire Size: 0.004" to 0.012" (0.002" Diameter Optional)
- Inverter Controlled Chiller
- RoboCut-LINKi Offline Cutting Monitor
- Power Saving Mode
- Positioning Accuracy:  $\pm 0.000050''$
- Heidenhain Glass Encoder (0.000002")

## Crash Protection

The system monitors servo data in real time, ensuring continuous protection against collision damage. When a crash occurs, the machine immediately stops. This feature is included in all RoboCut a-CiC models.

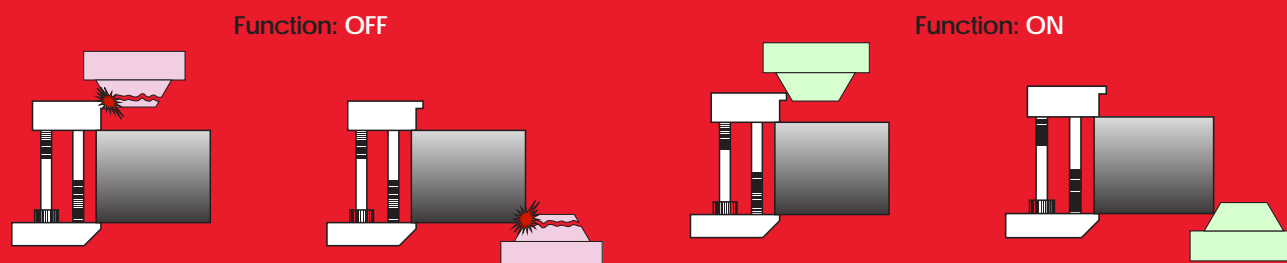

# Standard Features

## iPulse 3 Discharge Control

Take command and machine intricate shapes in a variety of materials with FANUC's new discharge control, the iPulse3. The improved discharge control enhances the ability to perform precise step- and corner-cuts with a greater level of accuracy.

With iPulse 3

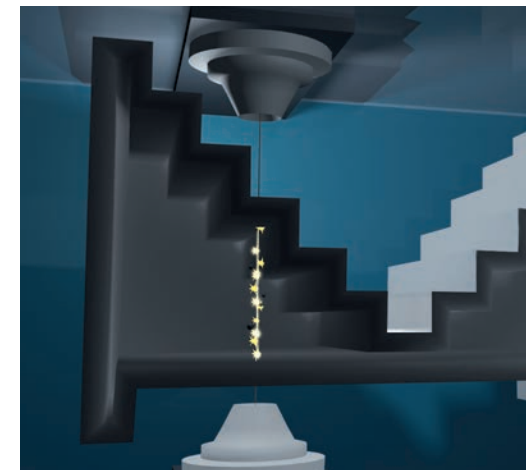

Without iPulse 3

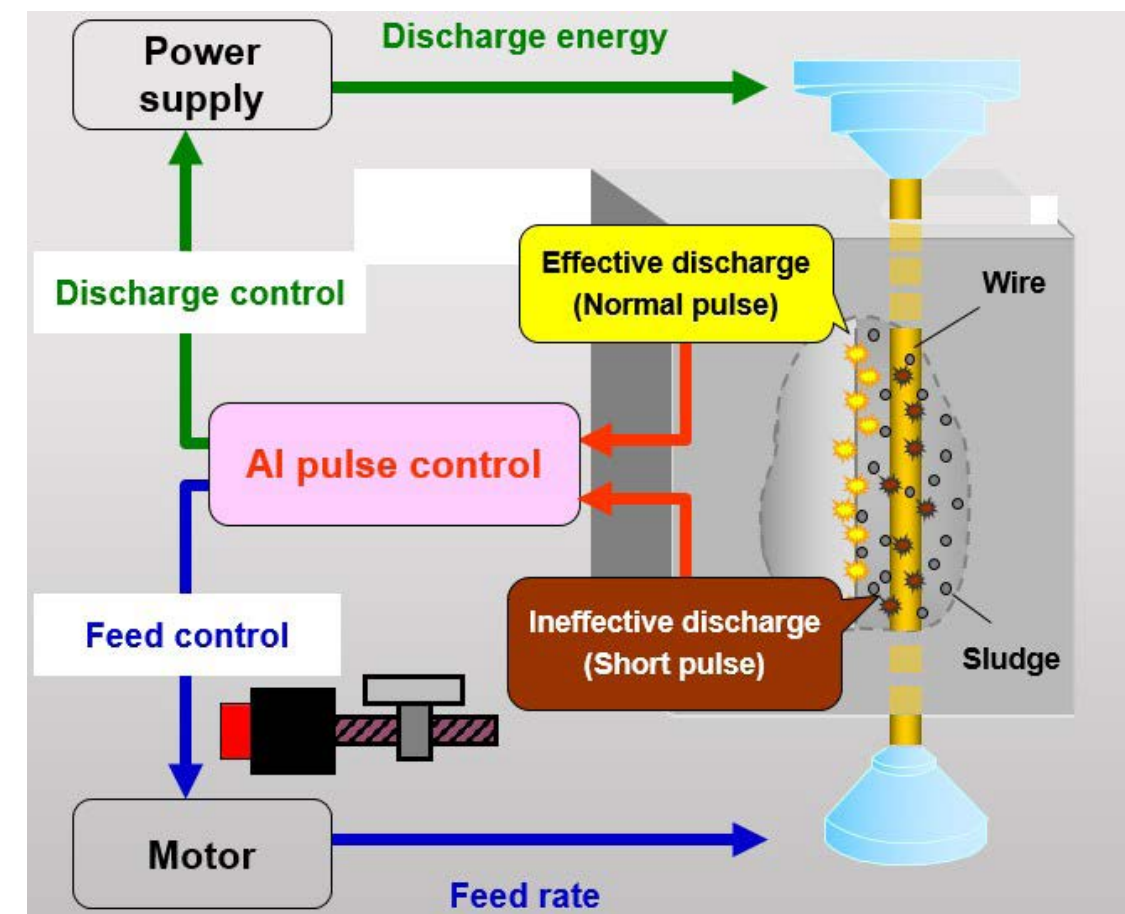
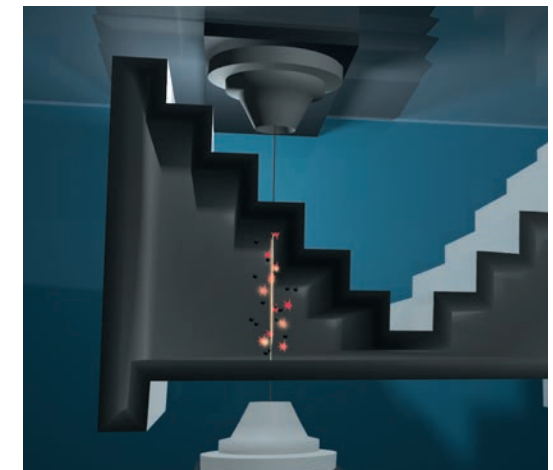



## AWF3: Reduced Cycle Times with Rapid, Reliable Automatic Wire Threading

Thread and re-thread wire through an entire work tank in the blink of an eye with FANUC's innovative automatic wire threading technology, AWF3. The unique system uses electricity to cut the wire with surgical precision, resulting in a straight, burr-free, tapered wire. By threading the wire through the full length of the work tank, operators can forego filling and draining the tank, reducing cycle times. The AWF3 can re-thread the wire at the breakpoint through the EDM kerf, eliminating the need to return to the start point. Additionally, the short release function allows operators to start machining in a short condition after the wire is connected.



The RoboCut does not need to return to the starting point after a wire break. This feature dramatically reduces machining times and by re-threading automatically in the wire path on workpieces.

## Industry-Leading Controls

Everything depends on machine tool control. Specifications and capabilities are important aspects of machining, but those components are meaningless if the operator can't control the machine properly. FANUC is world-renowned for its versatile, user-friendly CNC controls.

The α-CiC series is equipped with FANUC's 31i-WB control, which features power saving and energy recovery modes, lowering operating costs. The 31i-WB allows operators to constantly control and monitor data for up to seven axes for enhanced collision prevention.

- 15" touchscreen display
- Intuitive iHMI home screen
- Quick and easy data input
- Network access

- Fully functional pendant control

- Precise, predictive maintenance
- User-friendly automatic programming
- Easy-to-use control screen
- Supports multiple languages

- Fiber optic cable enables instant communication between control and machine
- Energy usage overview and low power functions
- Mouse and keyboard support via USB port
- Predefined shortcuts

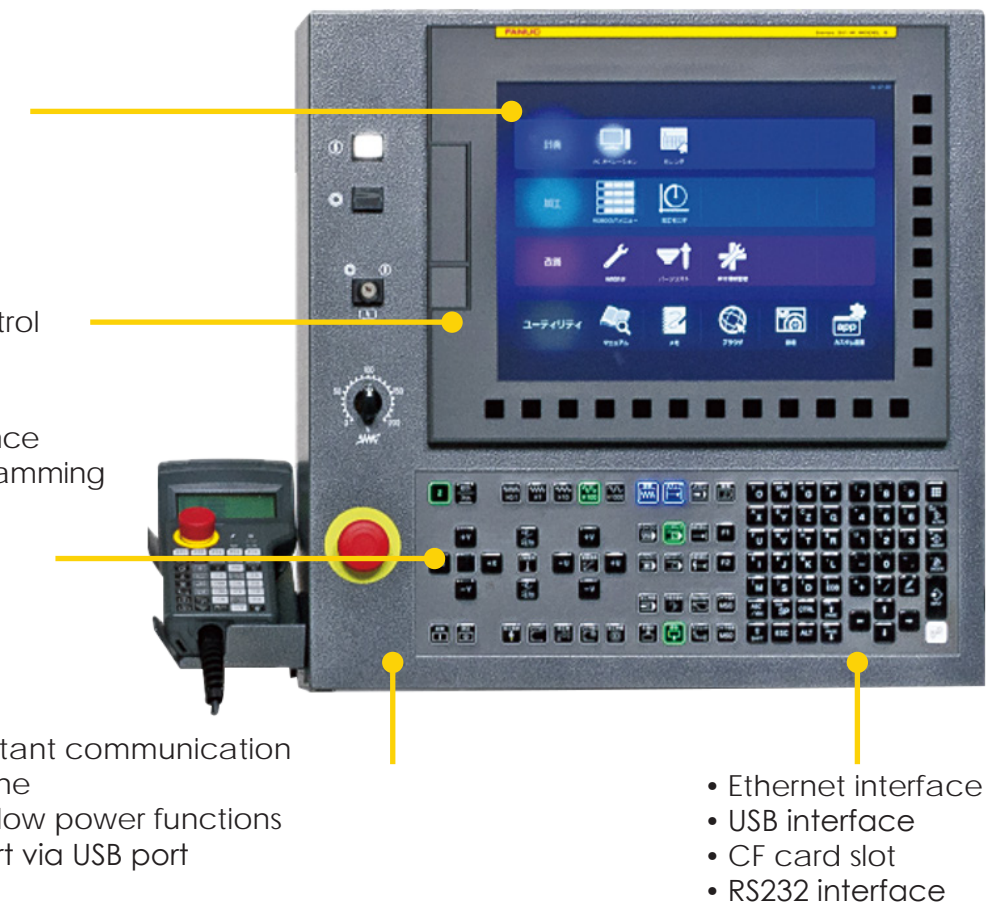

- Ethernet interface
- USB interface
- CF card slot
- RS232 interface

### Other Features Include:

- iH PRO panel which increases the drawing speed by 75% compared to the previous generation
- Effortlessly change cutting speed from 50% to 120% for greater stability
- Easily adjustable cutting technology and corner strategies
- Undo/redo function

# Standard Features

## LINKi: Remote Monitoring Made Easy

The LINKi is an interface that allows users to monitor the status of up to 32 RoboCut machines in real-time from remote computers or smart devices. Specific information is available for each cutting job, and users can send event-driven push notifications to different machines. The intuitive interface gives operators access to preventive maintenance functions as well as consumable and repair services. LINKi also allows users to transfer numerical control programs and run quality checks by comparing standard data to current cutting statuses.

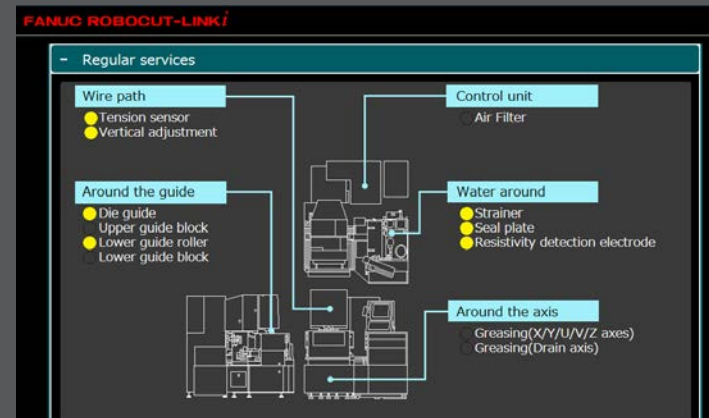
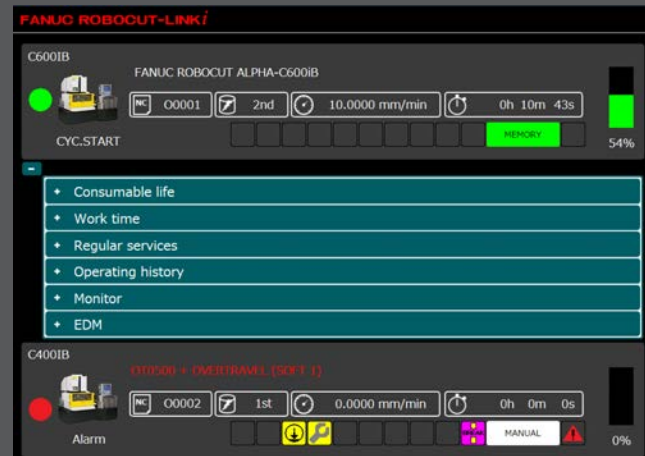

# Control Screens

## Artificial Intelligence Setting

FANUC's unique AI setting screen displays critical information such as wire diameter, material, and workpiece thickness in an easy-to-read format. Depending on the job's criteria, the AI screen shows information for single and multiple passes, allowing for easy selection of cutting technology.



## Cut Monitor Screen

FANUC developed the cut monitor screen to give the operator a comprehensive overview of a job to verify the information. Users can make real-time corrections with simple adjustments.

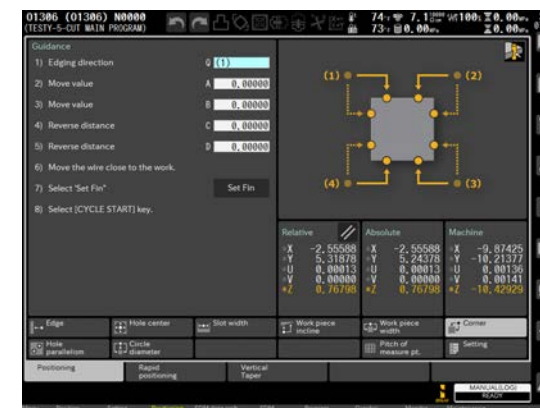

## Positioning Screens

All FANUC wire EDM machines utilize straightforward "pick up" modes which allow operators to locate their workpieces using the wire or an optional probe.

## Auto Programming Screen

Create custom geometry designs from scratch or import a DX file with the auto programming feature. The Robocut automatically creates the numerical control program after a path is created.





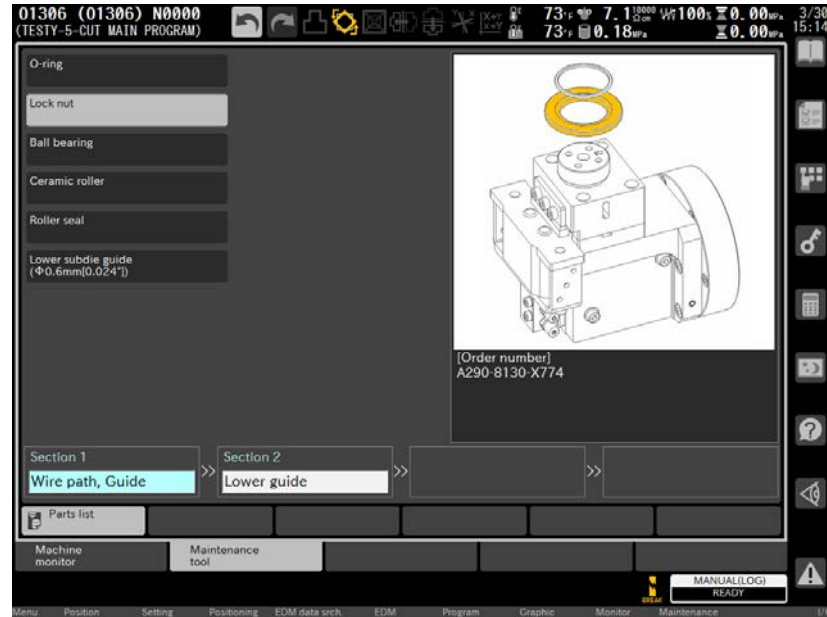

## Maintenance Screens

FANUC controls feature maintenance screens that give users easy step-by-step instructions and part numbers at their fingertips, rather than sifting through technical manuals.

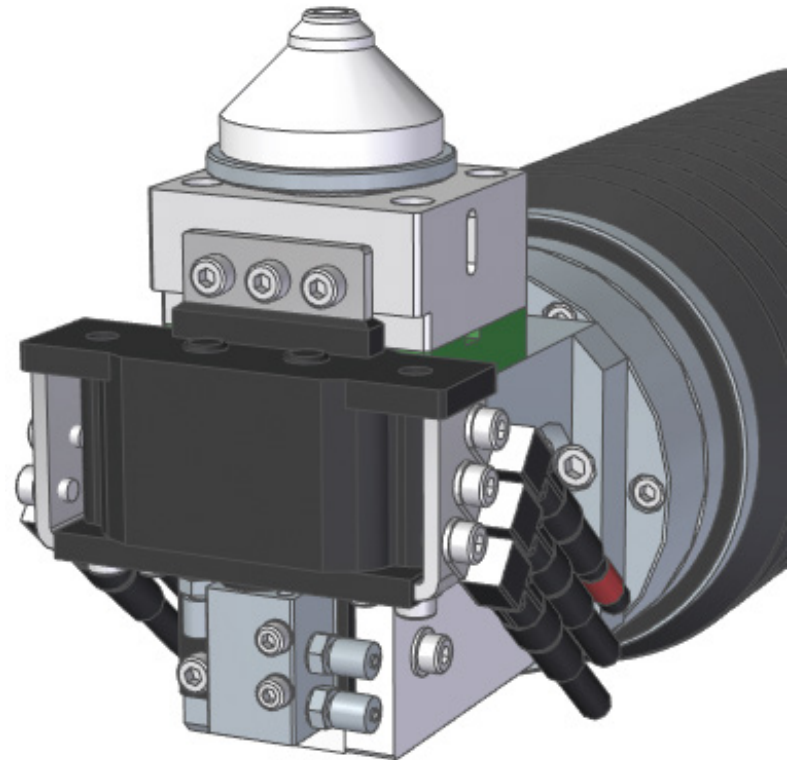

The machines display clear-cut instructions for maintenance operations, saving time and money.

## Seal Plate

The straightforward, effective seal plate continuously flushes clean water across the face of the seal plate to prevent contamination. The simple two-piece construction allows quick and easy cleaning. The improved construction of the CiC series drives the seal plate by the tank as opposed to the lower arm, eliminating drag and wear.

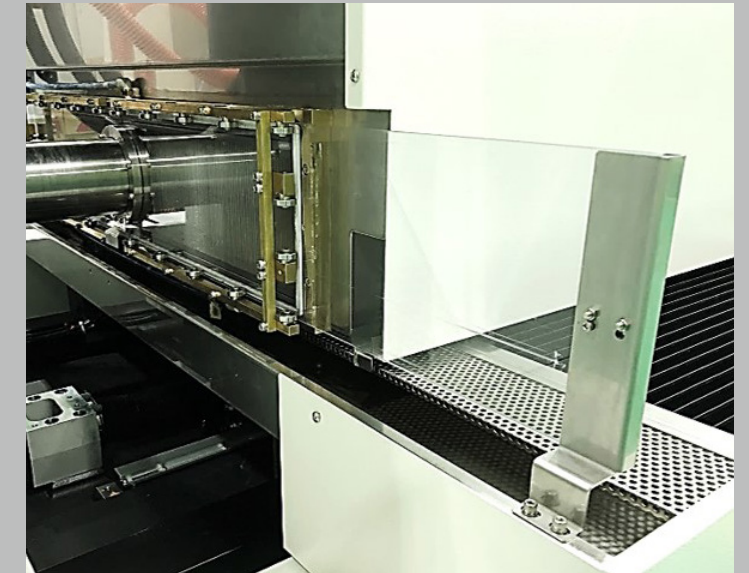

## Ball Screw

FANUC wire EDM ball screws are made with the highest quality material, double anchored, and pre-tensioned to ensure accuracy and reliability. FANUC also covers their ball screws to prevent impurities from reaching critical components, improving the screw's longevity. The addition of zerk fittings enable quick, straightforward maintenance procedures.

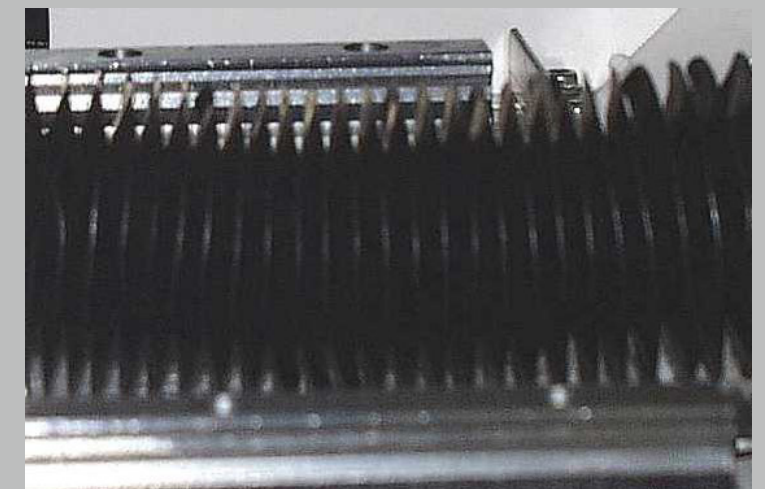
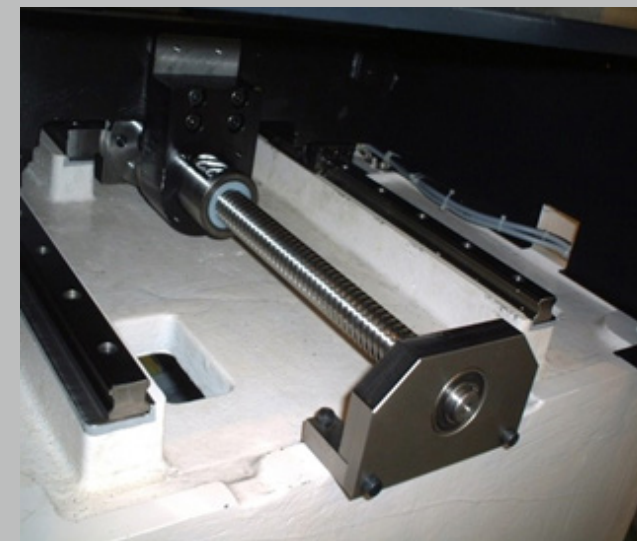

## Core Stitch

Program a complex, cumbersome job step back, and let the RoboCut and its core stitch function do the work. This technology allows operators to set stitch points, increasing the number of hours the RoboCut can run without manual intervention or additional operations. With core stitch technology, users tap out the cores, mitigating any risk to the machine and forgoing the need for glue tabs or magnets.

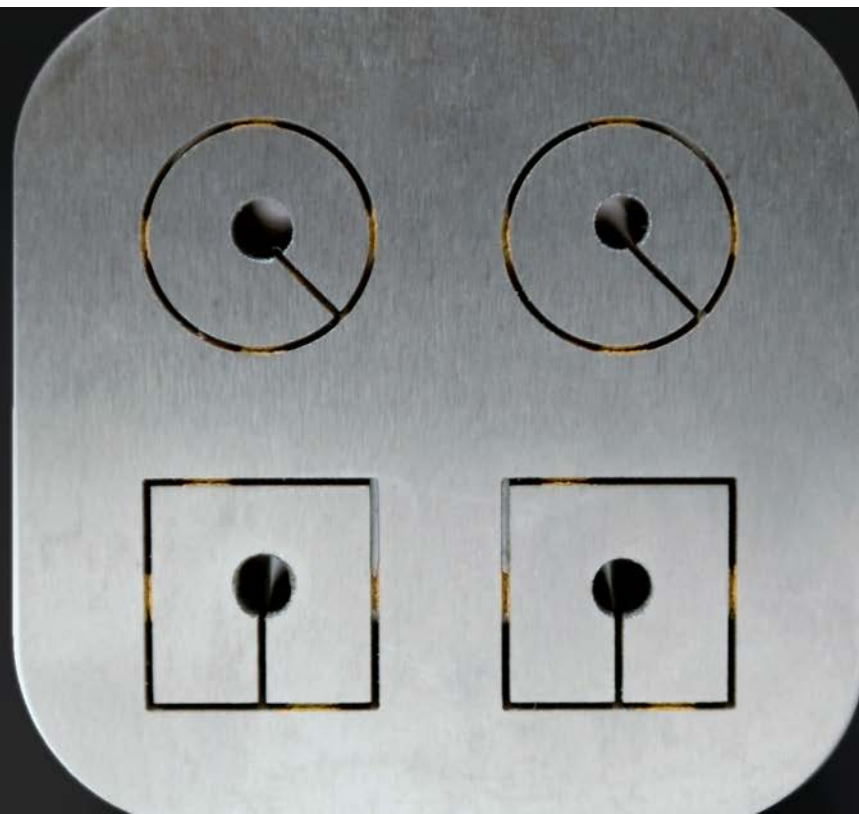
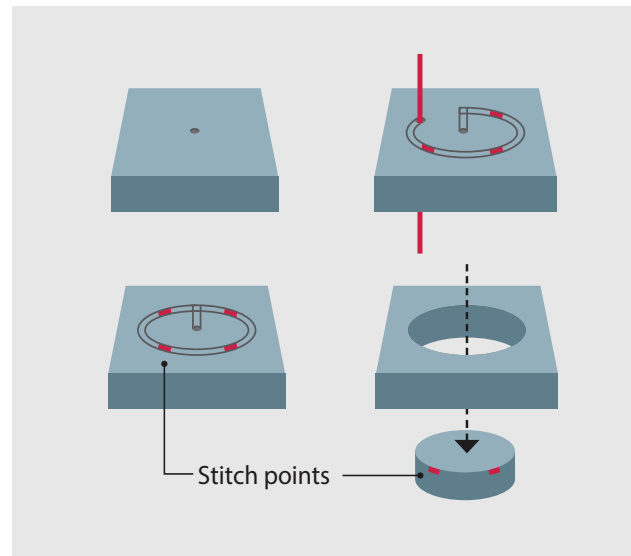

## Saving Energy, Saving Costs

The numerous energy-saving attributes embedded in the RoboCut reduce operating costs, enabling shop owners/managers to see a faster return on their investment. From motors and amplifiers to generators and pumps, every aspect of the machine is designed to consume the least amount of energy.



The power monitoring function allows the user to track energy usage during machining and standby. Other features include sleep mode, LED lighting, inverter pumps, auto startup via timer, auto-off functionality, and cooling and power regeneration.

### Power monitor

This energy-saving feature provides an overview of how much energy is being consumed and shows where operators can save energy.

### Sleep mode

The Robocut can automatically enter sleep mode during periods of inactivity for improved energy efficiency.





## Effortless Automation Integration: FANUC RoboCut, FANUC Robotics

FANUC machines are designed to work with FANUC robots, creating a flawless automation experience that maximizes throughput. Implementing automation is a painless process since all FANUC products communicate seamlessly with each other and share common servo and control platforms.



## CAMi Software

CAMi software unlocks the full potential of the RoboCut, giving users greater functionality and control from one central location. This optional program, driven by AI, enables users to choose the number of passes, view cutting conditions, and access surface finish and accuracy data. Core stitch functions, coreless cutting, four-axis taper programs, and other standard FANUC wire EDM functions are all easily available through CAMi software.

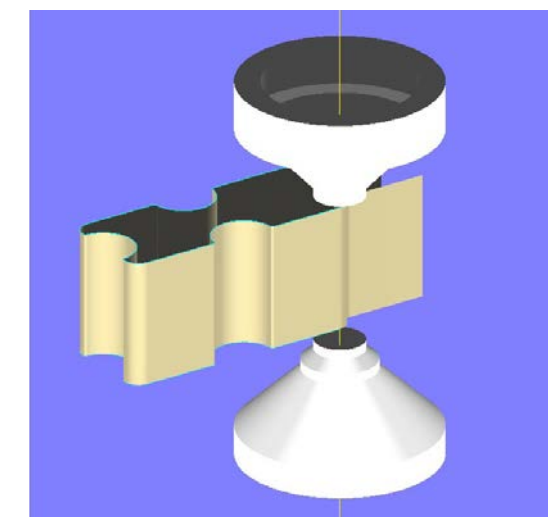
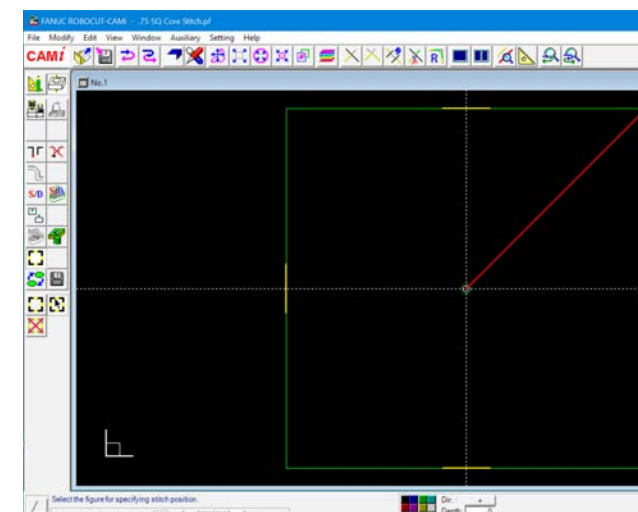
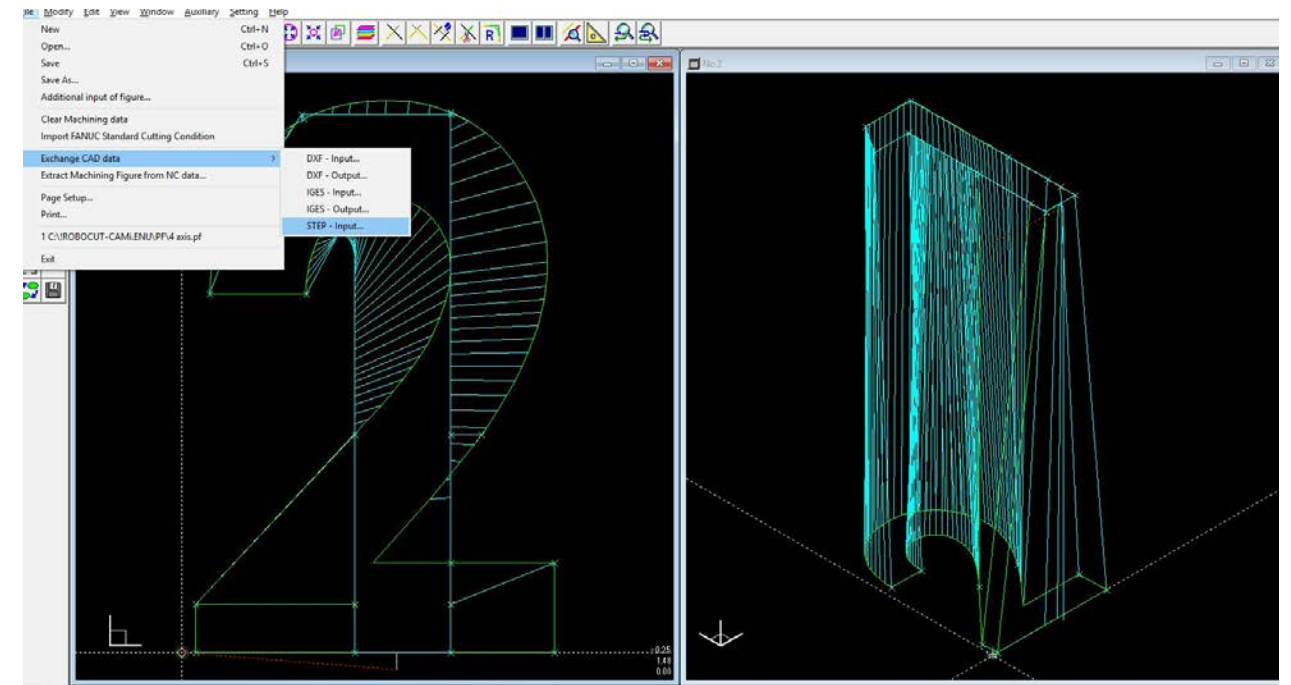



# Options

## AUTOMATIC FRONT DOOR

Users can remove the workpiece after draining a minimal amount of water from the machine, rather than completely draining it, saving valuable time.

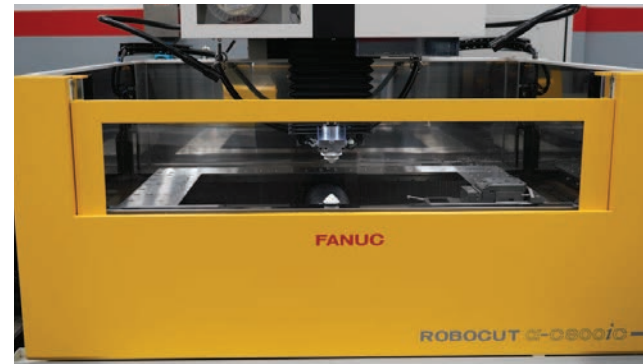

# Options

## ROTARY TABLE

Add a single-axis FANUC CCR or A/B-axis rotary table for simple indexing.



## PCD EDGE PROGRAMMING

Powered by GTR ProfDia, this software is the industry's choice for programming cutter profiles on flat and/or rotary cutting tools. PCD Edge guarantees tools are always cut on center.

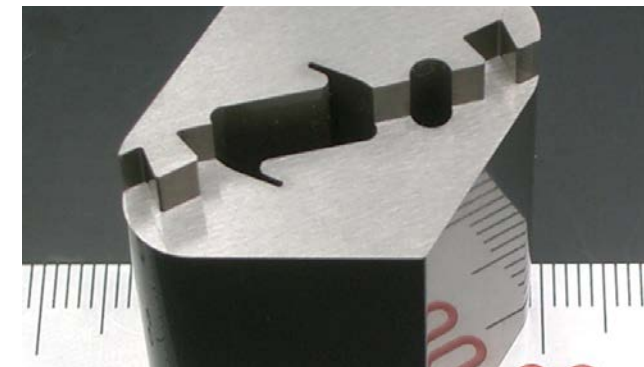

## MF2 FUNCTION

Achieve fine surface and mirror finishes while maintaining maximum accuracy and efficient cutting with FANUC's MF2 micro finish generator.

## SIXTY SIX-POUND AUTOMATIC WIRE LOADER

The auto-wire loader can be retrofitted for more than 140 hours of extended unmanned operation.



## LED TRIPLE ALARM LIGHT

Displays the operating status of the machine with red, yellow, and green lights.



## RENISHAW TOUCH PROBE

For precise automatic positioning and workpiece alignment, including 3D rotation function.

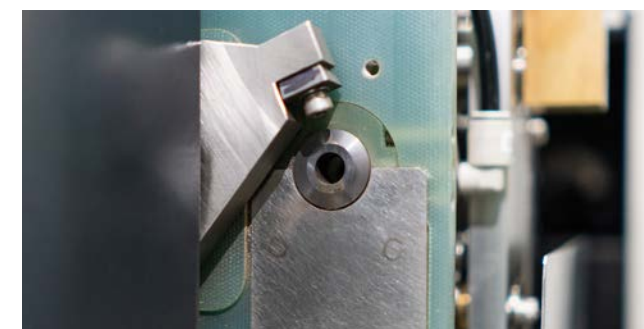

## WIRE CHOPPER

Allows the RoboCut to run unattended for longer periods of time, and is essential to adding automation to your machine.



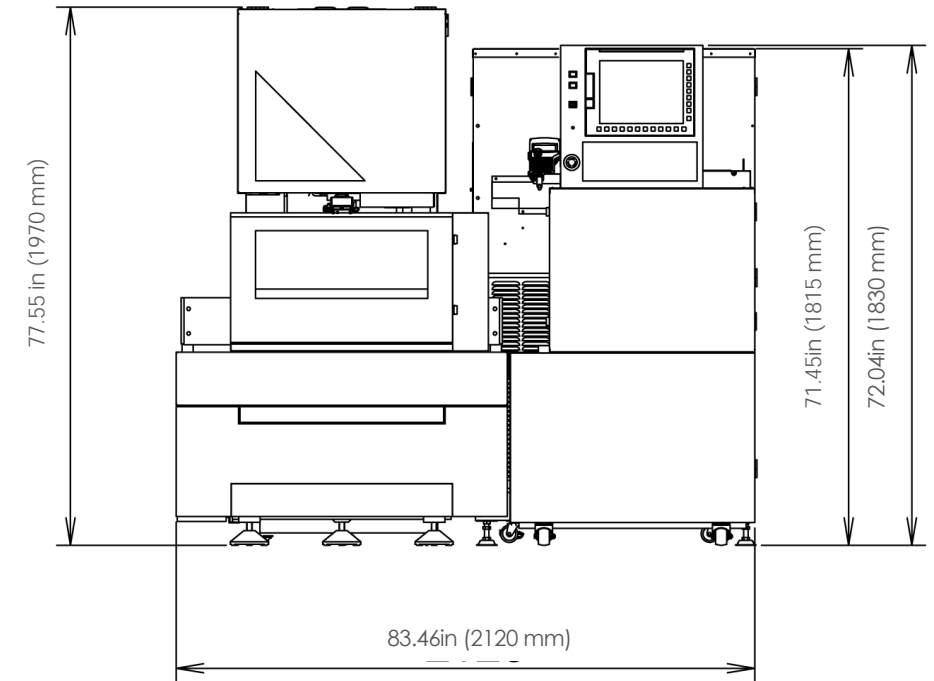

Features	Standard	Metric
Maximum workpiece dimensions	28.7" x 24.8" x 10.0"	730 mm x 630 mm x 255 mm
Maximum workpiece weight	1100 lbs	500 kg
X / Y Axis table travel	15.7" x 11.8"	400 mm x 300 mm
Z-Axis travel	10.0"	255 mm
U / V Axis travel	± 2.362"	± 60 mm
Maximum taper angle	± 30° / 3.15"	± 30° / 80 mm
Minimum step increment of the drives	0.000004"	0.0001 mm
Wire diameter	Ø 0.004" ~ 0.012"	Ø 0.10 mm ~ 0.30 mm
Maximum wire weight	35 lbs	16 kg
Machine weight (approx.)	4840 lbs	2200 kg
Controller	FANUC 31 i-WB	
Part program storage size (MB.)	4	
<b>Acoustic noise level</b>		
LPA (dB)	64	
LPC peak (dB)	81	
<b>Optional Features</b>		
<b>Thin Wire</b>		
Wire diameter	Ø 0.002" ~ Ø 0.012"	Ø 0.05 mm ~ Ø 0.3 mm
<b>45° die guide</b>		
Maximum taper angle	± 45° / 1.6"	± 45° / 40 mm
<b>30 kg wire feed unit</b>		
Maximum wire weight	66 lbs	30 kg

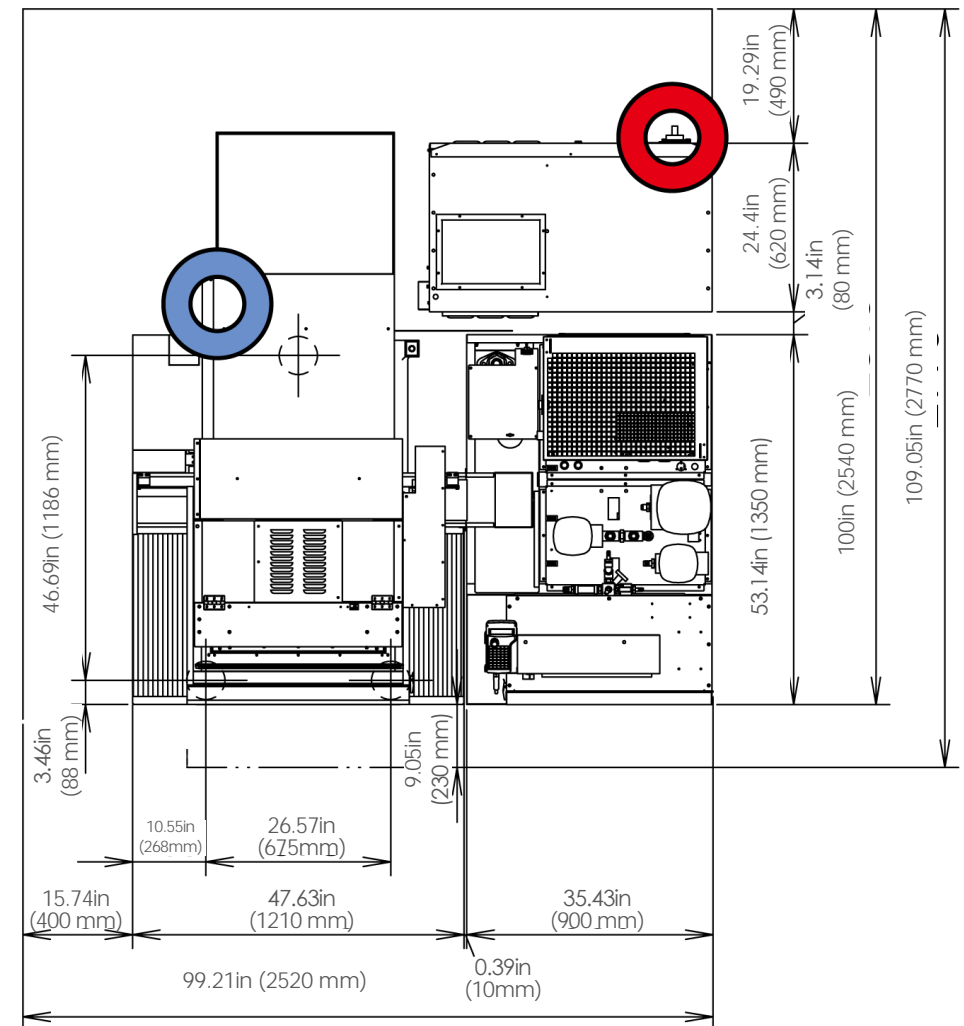



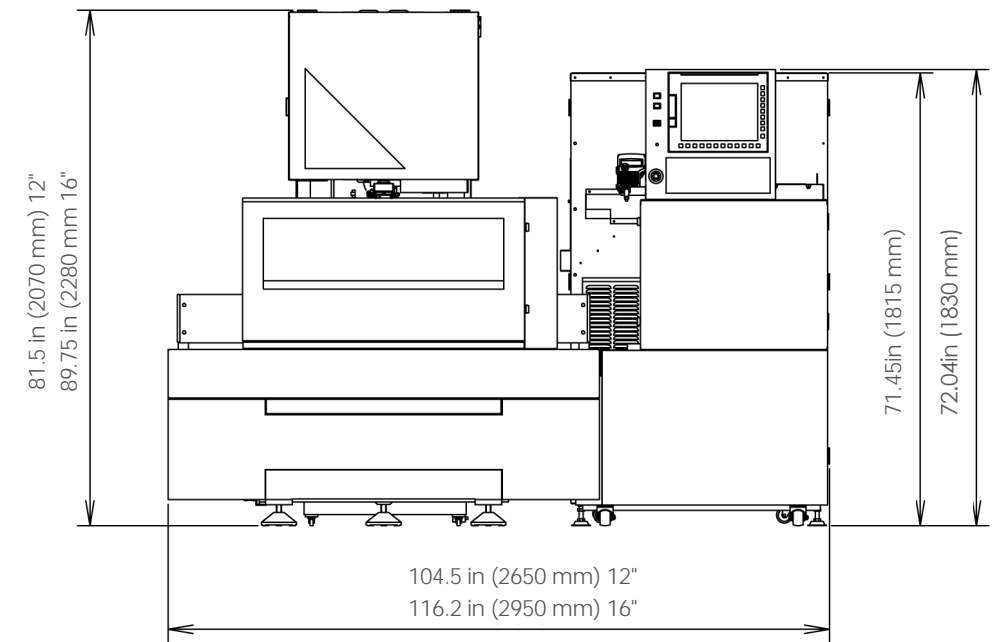

Features	Standard	Metric
Maximum workpiece Dimensions	41" x 32" x 12.2"	1050 mm x 820 mm x 310 mm
Maximum workpiece weight	2200 lbs	1000 kg
X / Y-axis table travel	23.6" x 15.7"	600 mm x 400 mm
Z-Axis travel	12.2"	310 mm
U / V-axis travel	± 3.937"	± 100 mm
Maximum taper angle	± 30° / 6.4"	± 30° / 150 mm
Minimum step increment of the drives	0.000004"	0.0001 mm
Wire diameter	Ø 0.004" ~ Ø 0.012"	Ø 0.10 mm ~ Ø 0.30 mm
Maximum wire weight	35 lbs	16 kg
Machine weight (approx.)	6700 lbs	3000 kg
Controller	FANUC 31 i-WB	
Part program storage size (MB.)	4	
<b>Acoustic noise level</b>		
LPA (dB)	64	
LPC peak(dB)	81	
<b>Optional Features</b>		
<b>Z axis 410</b>		
Z-axis travel	16.1"	410 mm
Maximum workpiece dimensions	41" x 32" x 15.7"	1050 mm x 820 mm x 410 mm
<b>45° die guide</b>		
Maximum taper angle	± 45° / 3.75"	± 45° / 70 mm
<b>30 kg wire feed unit</b>		
Maximum wire weight	66 lbs	30 kg

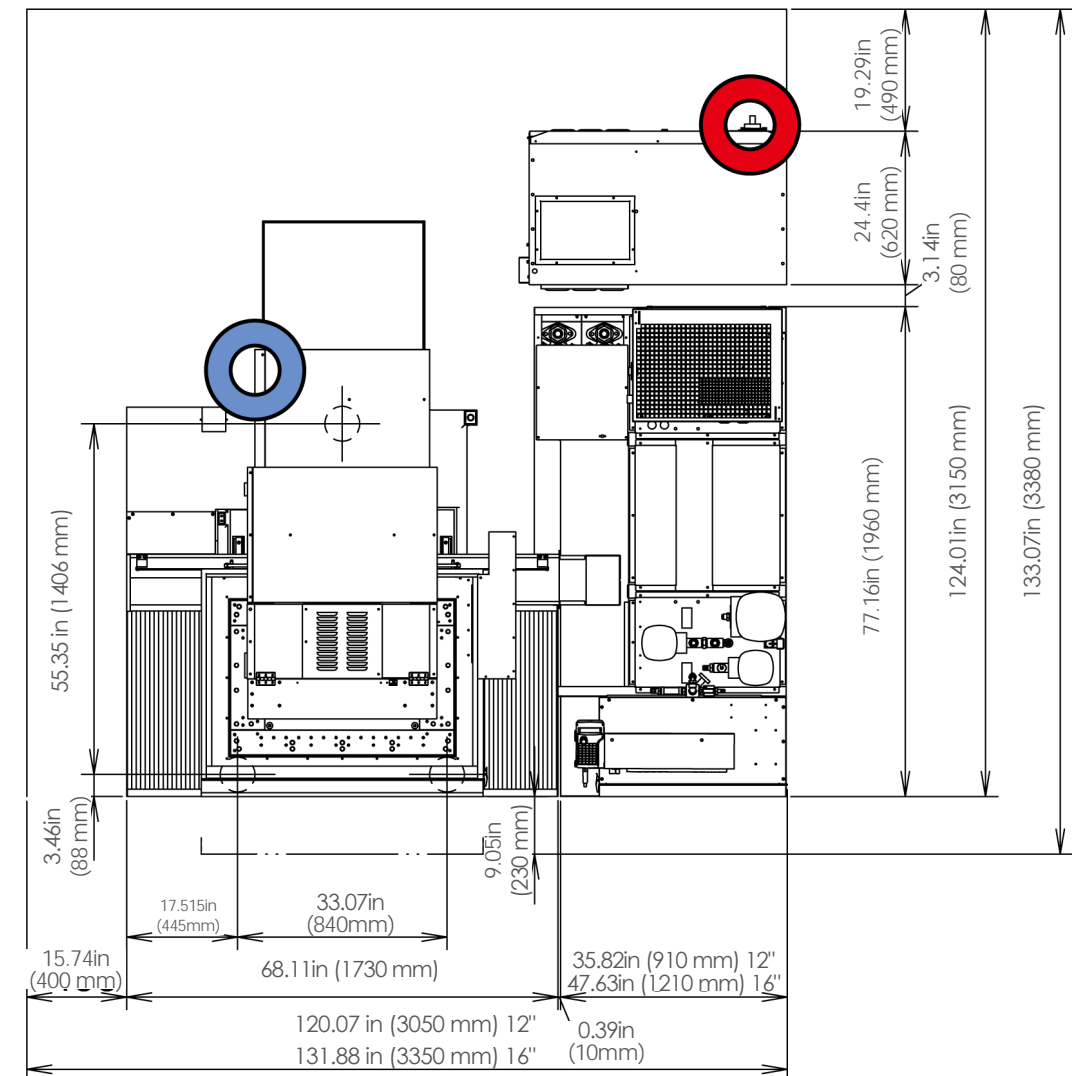



# About FANUC

## About FANUC | Service First

FANUC is committed to maximizing uptime. The company's products are known throughout the industry for their stability, reliability, and versatility.

The company achieved many "firsts" in its rich history, including the first numerical control and servo system in Japan's private sector. Like Methods, FANUC utilizes leading-edge technology and decades of machining knowledge to solve challenges while maintaining a customer-focused mindset.



# About Methods



## About Methods Machine Tools | Engineered for Results

Methods was founded in 1958 with three employees and a handful of refurbished machines. Since then, we have become one of the largest privately-owned suppliers of leading-edge precision machine tools and automation systems in North America. We attribute our success and growth to our unique, steadfast commitment to dependable customer service. We don't just sell machines; we craft unique machining configurations and setups to help customers reach new efficiency and profitability levels.

Methods provides superior products, engineering, service, parts, training, and integration. With more than 300 employees, nine technical centers, and a precision center, Methods has installed more than 40,000 machines throughout North America.



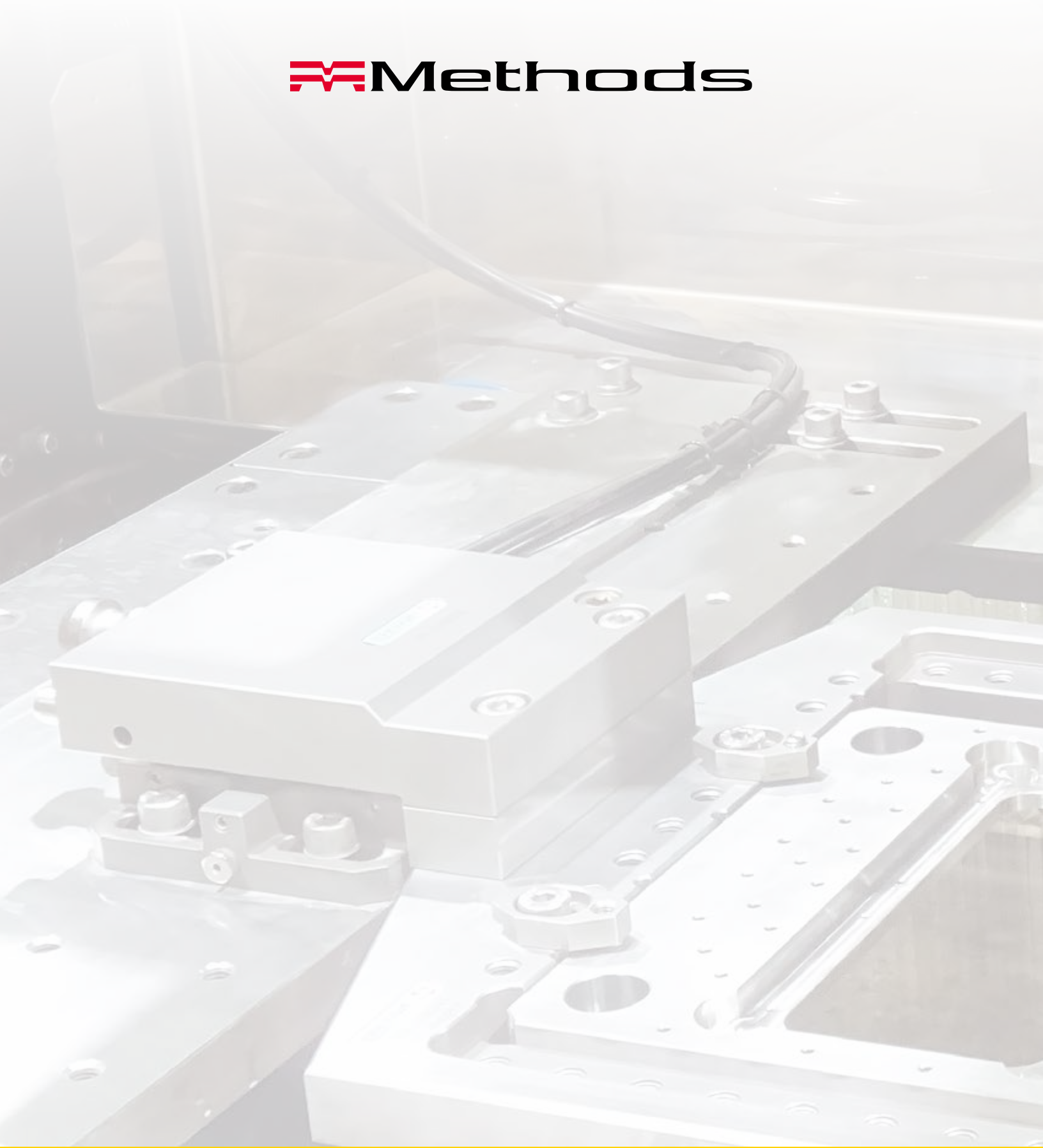

## Showrooms and Technical Centers

Boston ■ Charlotte ■ Chicago ■ Detroit ■ Los Angeles  
Memphis ■ Milwaukee ■ Phoenix ■ San Francisco

[methodsmachine.com](http://methodsmachine.com) | 877-668-4262