

Vertical Machining Center / 5-Axis Machining Center

# KCV SERIES

KCV1000

KCV1000-5AX



# KCV SERIES

**From Aircraft parts to Large LCD components, its flexible design meets the users needs.**

KCV1000



Touch sensor is optional

Conquering a wide range of applications from general to long work-pieces.

Exceptional productivity with large strokes.

In a continuous pursuit of high rigidity and high speed processing, KCV is the embodiment of overall efficient operations.

A highly rigid machine body design produces powerful cutting performance.

The traverse column provides excellent accessibility, operability and extensibility.

An advanced controller facilitates the finest quality throughout high speed and rapid response machining.

KCV1000-5AX



## Exceptional productivity with large strokes.

### Highly rigid machine structure produces highly accurate processing.

Solid thick walled structure of the bed and column provides high rigidity and stiffness. The table is fully supported without overhang allowing heavy work-piece and long life.

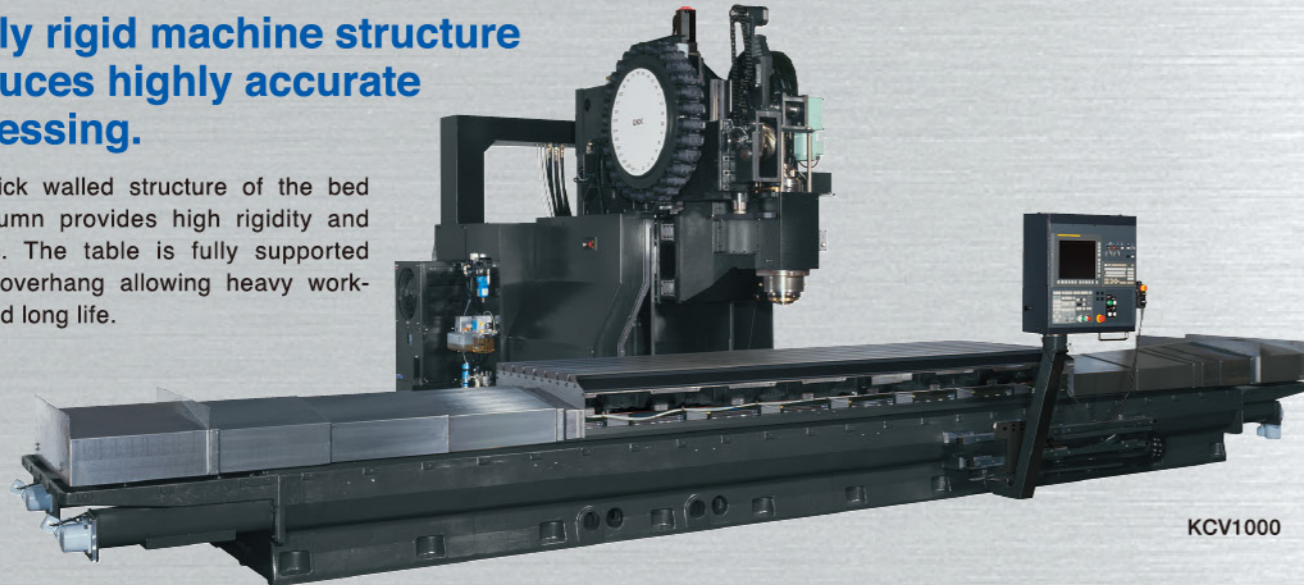

KCV1000

### Comprehensive chip processing measures

Coil conveyors are provided as standard equipment at the front and back of the table for improved chip discharge.

In addition, coil conveyors are added on the right and left sides of the column, and chips on the front of the column and on both sides of the X-axis shutter fall and are discharged from the machine onto the conveyor.

The coil conveyor is equipped with a reverse rotation function for easy discharge of chips even if they are stuck.

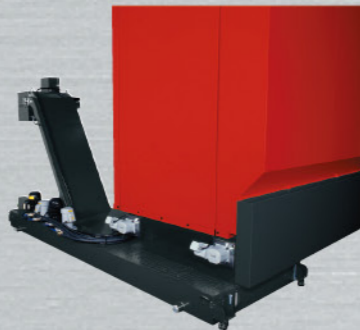

KCV1000



### Operator friendly traversing column

Traversing column ensures easy access to fixtures enabling quick setup and work piece loading.

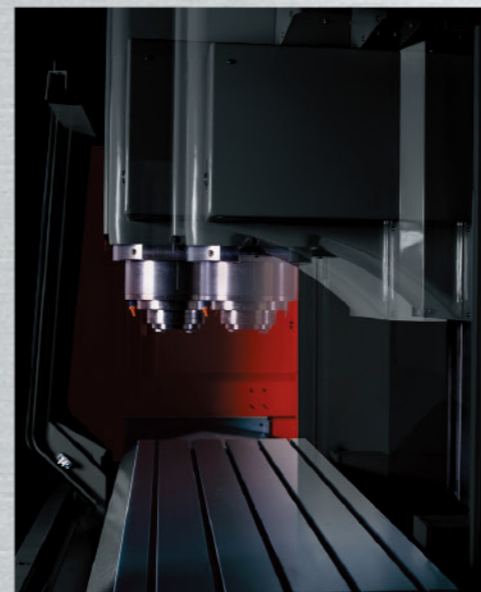

KCV1000

### Thorough measures to control thermal displacement

Bearing heat is suppressed by usage of a spindle housing cooling mechanism; further the KCV1000 implements core chilled ball screws in the feed axis and utilizes a spindle coolant walljacket design. These measures improve processing accuracy and stability.



KCV1000-5AX

### Highly rigid feed systems

Accurate and highly rigid linear ball guides are used on the axis guide faces and linear roller guides. For the feed screw supports a double anchoring method that ensures high feeding rigidity is adopted to realize high-speed response and powerful cutting performances.

### Movable operation panel

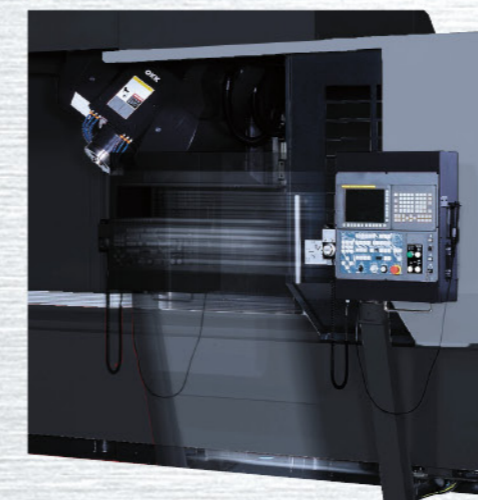

KCV1000-5AX

### ATC mechanism

The ATC unit of high-speed cam interlock method supports highly efficient processing: Tool exchange time of 2.5 seconds with #50 tools (tool-to-tool). (KCV1000-5AX is arm swing type)



KCV1000

### Maintenance-free structure

Designed to be the ultimate in safety and ease of operation. KCV1000 eliminated hydraulic equipment, decreasing power consumption, noise, and maintenance at KCV1000.

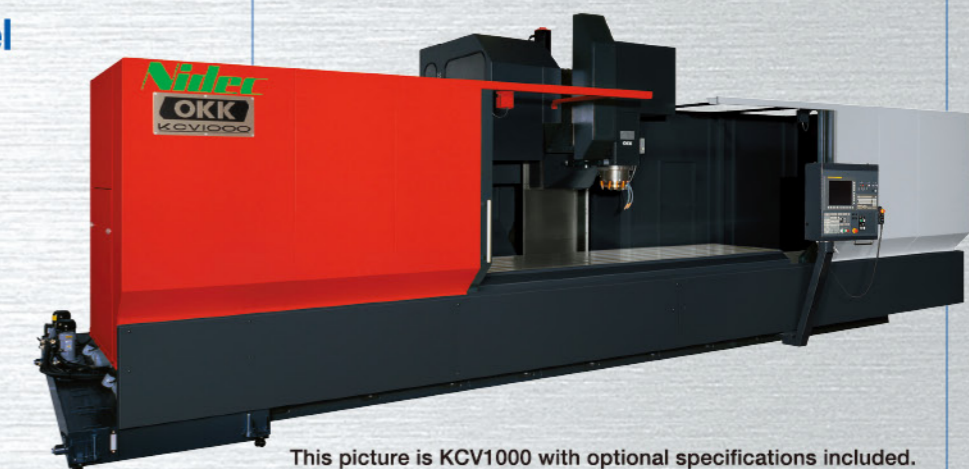

This picture is KCV1000 with optional specifications included.

# KCV SERIES

# VERTICAL MACHINING CENTER

## KCV1000

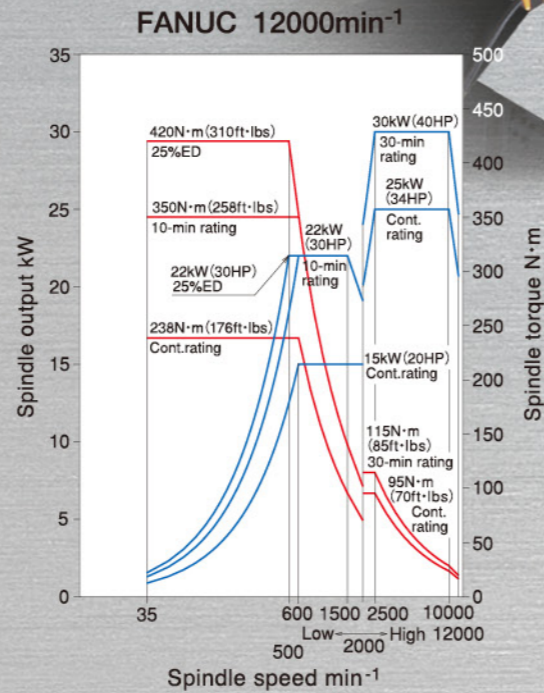
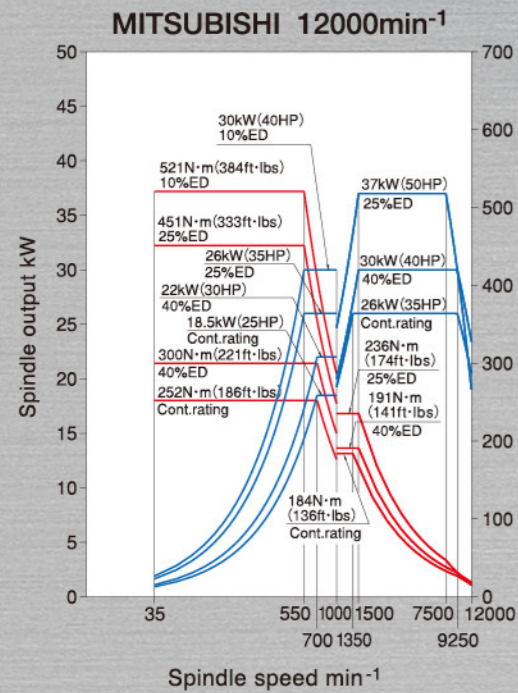

## KCV1000-5AX

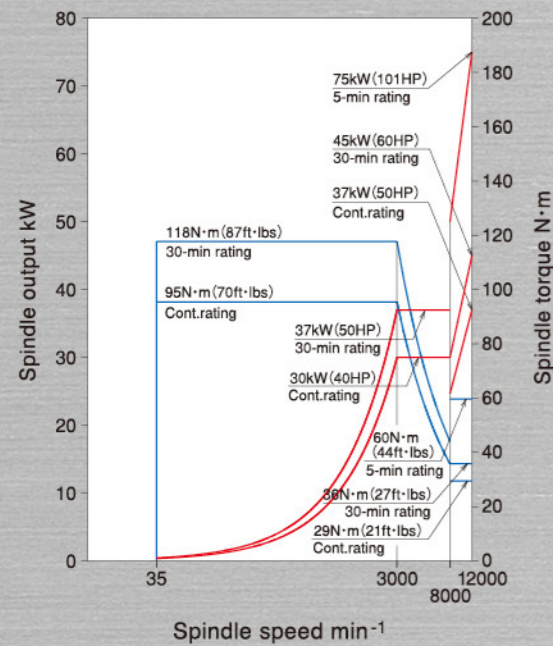

### Accuracy of KCV1000/KCV1000-5AX

**Positioning accuracy (without linear scale)** mm (inch)

	X	Y	Z
Positioning Accuracy	±0.0090 (0.00035") /fill stroke	±0.0030 (0.00012") /fill stroke	±0.0050 (0.00020") /fill stroke
Repeatability	±0.0020 (0.00008") /fill stroke (Nidec OKK tolerance)		

**Positioning accuracy (with linear scale)** mm (inch)

	X	Y	Z
Positioning Accuracy	KCV1000-5AX ±0.0060 (0.00024") /fill stroke	±0.0020 (0.00008") /fill stroke	±0.0030 (0.00012") /fill stroke
Accuracy	KCV1000 ±0.0050 (0.00020") /fill stroke	±0.0020 (0.00008") /fill stroke	±0.0030 (0.00012") /fill stroke
Repeatability	±0.0010 (0.00004") /fill stroke (Nidec OKK tolerance)		

**Positioning accuracy (with encoder)** (sec)

Positioning Accuracy	A axis: ±5 sec	B axis: ±5 sec
----------------------	----------------	----------------

KCV1000-5AX only. (Nidec OKK tolerance)

Remarks  
 1. The above sample data show the short-time machining examples and the results of continuous machining may differ from them.  
 2. The above sample data show the accuracies under Nidec OKK's in-house cutting test conditions. The results may vary with the conditions of the cutting tools and fixtures.

**Circular cutting accuracy** mm (inch)

Item	Nidec OKK tolerance	Result
Circularity	0.015 (0.00059")	0.0058 (0.00023")

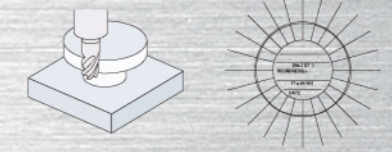

**Cutting accuracy** mm (inch)

Item	Nidec OKK tolerance	Result
Axis direction	0.015 (0.00059")	0.007 (0.00028")
Diagonal direction	0.015 (0.00059")	0.008 (0.00031")
Deviation of hole dia.	0.010 (0.0004")	0.005 (0.00020")

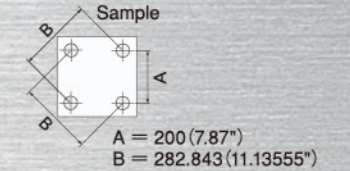
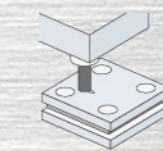

### Machining Capabilities (Examples of cutting data)

	kW (HP)	Face Mill		Roughing End Mill		Roughing End Mill	
		5" × 6t		φ40 × 6t	φ50 × 6t	φ40 × 6t	φ50 × 6t
		KCV1000	KCV1000-5AX	KCV1000	KCV1000-5AX	KCV1000	KCV1000-5AX
Spindle		30/26 (40/35)	45/37 (60/50)	30/26 (40/35)	45/37 (60/50)	30/26 (40/35)	45/37 (60/50)
Workpiece material		S45C	S45C	S45C	S45C	S45C	S45C
Spindle rotating speed	min <sup>-1</sup>	300	300	200	160	200	160
Cutting speed	m/min (ipm)	118 (4646)	120 (4724)	25 (984)	25 (984)	25 (984)	25 (984)
Cut width	mm (inch)	(A) 100 (3.94)	(A) 100 (3.94)	(C) 20 (0.79)	(C) 50 (1.97)	(E) 40 (1.57)	(E) 50 (1.97)
Cut depth	mm (inch)	(B) 6 (0.24)	(B) 3 (0.12)	(D) 50 (1.97)	(D) 5 (0.20)	(F) 15 (0.59)	(F) 5 (0.20)
Feed rate	mm/min (ipm)	500 (20)	300 (12)	200 (8)	140 (6)	300 (12)	192 (8)
Feed per tooth	mm (inch) /tooth	0.278 (0.011)	0.167 (0.007)	0.167 (0.007)	0.146 (0.006)	0.250 (0.010)	0.200 (0.008)
Cutting amount	cm <sup>3</sup> (in <sup>3</sup> ) /min	300 (18.3)	90 (5.5)	200 (12.2)	35 (2.1)	180 (11)	48 (2.9)
Spindle motor load	%	120	129	100	100	95	111

Note: The above machining data are only an example for reference.

## Standard Specifications

		KCV1000	KCV1000-5AX	
Travel	Travel on X axis (Table horizontal direction)	3500 (137.80")		
	Travel on Y axis (Column front-back direction)	1020+5 (ATCst) (40.16"+0.2")		
Table	Travel on Z axis (Spindle head vertical direction)	720 (28.35")		
	Travel on A axis (Spindle head front-back direction)	deg — —40~40		
	Travel on B axis (Spindle head horizontal direction)	deg — —40~40		
	Distance from table top surface to spindle nose	200~920 (7.87"~36.22")		
	Distance from column front to spindle center	1085 (42.72")		
	Table work surface area (X-axis direction × Y-axis direction)	3800×1020 (149.61"×40.16")		
Spindle	Max. workpiece mass loadable on table	4000 (8800 lbs)		
	Table work surface configuration (Number and nominal dimension of T slots and spacing)	22×140×7 tools (0.87"×5.51"×7)		
	Distance to the table work surface from the floor	1000 (39.37")		
	Spindle rotating speed	35~12000		
Feed Rate	Number of spindle speed change steps	Electrical two-speed control (MS)		
	Spindle nose (nominal number)	7/24 taper No.50		
	Spindle bearing bore diameter	φ 100 (dia.3.94")		
	Rapid traverse rate	X, Y and Z axes: m/min	20 (787ipm)	
	Cutting feed rate	A and B axes: deg/min	— 3600	
		X, Y and Z axes: mm/min	1~10000*1 (0.04 to 394ipm)	
	JOG feed rate	A and B axes: deg/min	— 0.001~3600	
		X, Y and Z axes: mm/min	2000 (79ipm)	
	Automatic Tool Changer	A and B axes: deg/min	— 2000	
		Tool shank (nominal number)	JIS B 6339 BT50	
Pull stud (nominal number)		OKK only 90°		
Number of storable tools		30		
Maximum tool diameter (with adjacent tools)		φ100 (dia.3.94")		
Maximum tool diameter (without adjacent tools)		φ200 (dia.7.87")		
Maximum tool length (from the gauge line)		350 (13.78")		
Maximum tool mass		20 (44 lbs)		
Tool selection method		Memory random method	Add fixed method	
Tool exchange time (tool-to-tool)		sec 2.5		
Motors	Tool exchange time (cut-to-cut)	sec 8.5 15		
	For spindle (30-min rating/continuous rating)	kW MISUBISHI 30/26 (40/35HP) FANUC 30/25 (40/34HP) FANUC 45/37 (60/50HP)		
	For spindle/ball screw cooling oil temperature controller (compression/discharge)	kW 1.5/0.75 (2/1HP)		
	For spindle oil-air lubrication pump	kW — 0.018 (0.02HP)		
	For feed supply	X, Y and Z axes: kW(HP)	MITSUBISHI XYZ : 7(9.4) FANUC X : 6(8) Y : 7(9.4) Z : 9(12.1) FANUC XY:9.0(12.1) Z:9.0×2(12.1×2)	
		A and B axes: kW	— FANUC AB:4.0(5.4HP)	
	For feed guide surface lubrication pump	kW 0.017 (0.02HP)		
	For coolant pump	kW 1.1×1 (1.5HP×1) 0.4×2 (0.5HP×2)		
	Workpiece flushing gun	kW 1.1 (1.5HP)		
	For turning ATC/unclamping a tool on the spindle	kW 0.75 (1HP) Turning ATC : 0.4 (0.5HP)*2		
	For moving ATC	kW — 0.5 (0.7HP)		
	For turning magazine	kW — 0.4 (0.5HP)		
	For driving pots	kW 0.09 (0.12HP) —		
	For coil conveyors	kW X : 0.2×2 (0.3HP×2) Y : 0.1×2 (0.15HP×2)		
	For hydraulic unit	kW — 1.5 (2HP)		
Required Power Sources	Power supply	kVA MITSUBISHI : 68 FANUC : 63 FANUC : 107		
	Supply voltage × supply frequency	V × Hz 200V±10%×50/60Hz±1 220V±10%×60Hz±1*3		
	Compressed air supply pressure	MPa 0.4~0.6*4 (58~87psi)		
Tank Capacity	Compressed air supply flow rate	L/min-1(ANR) 600*5 (159gpm) 400*5 (106gpm)		
	Coolant tank	L 700 (185gal) 1100 (291gal)		
	Spindle head cooling oil tank	L — 70 (18gal)		
	Spindle lubricating oil tank	L — 2 (0.5gal)		
	Slideway lubricating oil tank	L — 6 (1.6gal)		
	Hydraulic unit tank	L — 20 (5gal)		
Machine Size and Required Floor Space	Machine height from the floor surface	mm 3459 (136.18") 3730 (146.85")		
	Floor space required for operation (width × depth)	mm 9420×5253 (370.87"×206.81") 9714×5793 (382.44"×228.07")		
	Floor space including maintenance area (width × depth)	mm 11000×6000 (433.07"×236.22") 10714×6293 (421.81"×247.76")		
	Machine mass	kg 28000 (61700 lbs) 32000 (70500 lbs)		
Controller type	Controller type	F31iB Plus (FANUC)/N830 (MITSUBISHI) F30iB Plus (FANUC)		
	Temperature of operation environment	°C 5~40		

\*1 : Feed rate under the HQ or Hyper HQ control. (Hyper HQ II is standard for 5AX.)  
 \*2 : KCV1000-5AX uses the hydraulic system for unclamping tools.  
 \*3 : When the supply voltage is 220VAC, the supply frequency of 60Hz only is applicable.

\*4 : Purity of the supplied air should be equivalent to or higher than the Classes 3, 5 and 4 specified in ISO 8573-1/JIS B 8392-1.  
 \*5 : When optional specification such as an air blow is added, add appropriate air supply according to the operating frequency.

## Standard accessories

		KCV1000	KCV1000-5AX
Lighting system	Specification		Two LED lamps
	Coolant unit with lift-up type chip conveyor	Hinged type	Backwashing and filtration type aluminum chips
Coolant-through-spindle (Spindle compatibility only)	—		1set
Air blower	1set		—
Entire machine cover (Splash guard)	—		1set
Door interlock control	—		1set
Top cover	—		1set
Signal lamp	—		1 set (3-lamp tower type with alarm buzzer)
Workpiece flushing gun (moderate pressure)	—		1set
ATC shutter	—		1set
Slideway protection covers for X, Y and Z axes	—		1set
Feed system lubrication unit	—		1set
Spindle head and ball screw cooling oil temperature controller	—		1set
Hydraulic unit	—		1set
Coil conveyor with reverse rotation function	—		1set
Leveling block	—		1set
Foundation parts	—		1 set (including 3 × 330-ml bond for anchoring)
Parts for machine transfer (excluding the hoisting jig)	—		1set
Automatic power off	—		1set
Rotary encoder (A axis/B axis)	—		1set
Electrical spare parts (fuses)	—		1set
Instruction manual	—		1set
Electrical manuals (including electrical diagrams)	—		1set

## Special accessories

		KCV1000	KCV1000-5AX
Compatibility with two-surface locking tool	Specification		□
	Compatibility with MAS pull stud	MAS I / MAS II	
Number of storable tools	—		40 tools
Linear scale	—		XY axes / XYZ axes
Lift-up type chip conveyor	□ Scraper type		—
	□ Scraper type with floor magnet		
	□ Drum type for aluminum chips		
Chip bucket	□		—
Oil skimmer	□		—
Mist collector	□		—
Compatibility with oil-hole holder	□ Big □ NIKKEN		—
	Including 1.1-kW coolant pump		
Thickener bag filter (Spare parts for high-pressure unit)	□		—
HIGH SPINDLE ATM installation work	□ Big □ NIKKEN		—
Compatibility with through-spindle	□ 2Mpa □ 7Mpa □ Air		Including 7-MPa high-pressure unit
Air blower	—		□
Oil mist blower	□		—
Coolant cooler	□		—
Splash guard front door automatic operation	□		—
ATC shutter	□		—
NC rotary table	□ Type of rotary table specified by customer		—
Sub table	□ T-slot fixing type specified by customer		—
Touch sensor system T1 (automatic)	□ T1-A (Workpiece measurement)		—
	□ T1-B (Workpiece measurement, Tool length measurement, Tool break detection)		
Tool break detection with limit switch	□		—
Tool length/diameter measurement with laser	□ Renishaw laser system with no cover (□ Max φ85 / □ Max φ135 / □ Max φ85)		—
	□ BLUM Micro with no cover (□ Max φ85)		
Addition of M signals	□ 4 sets □ 8 sets		—
Standard tool set	□		—
Specified coating color	□		—
Magazine operation panel	□		—

# KCV1000

## Main Dimensions

# KCV1000-5AX

## Main Dimensions

Side view

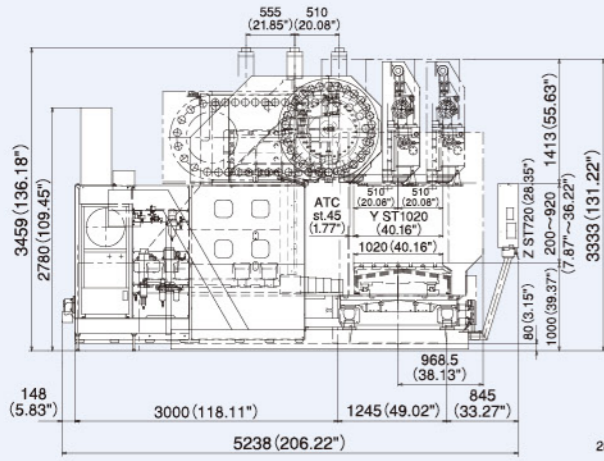

Front view

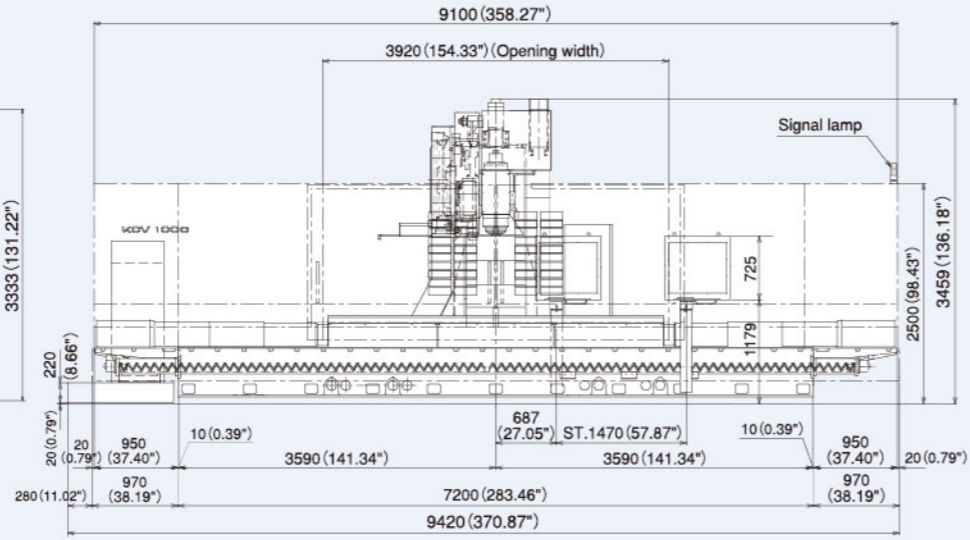

Side view

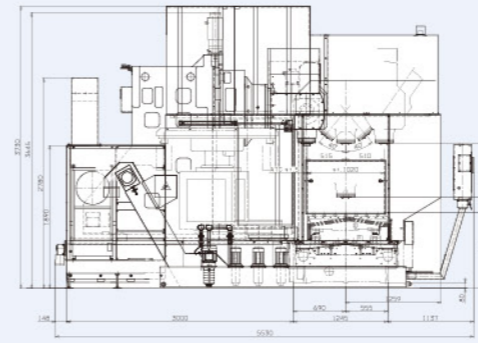

Front view

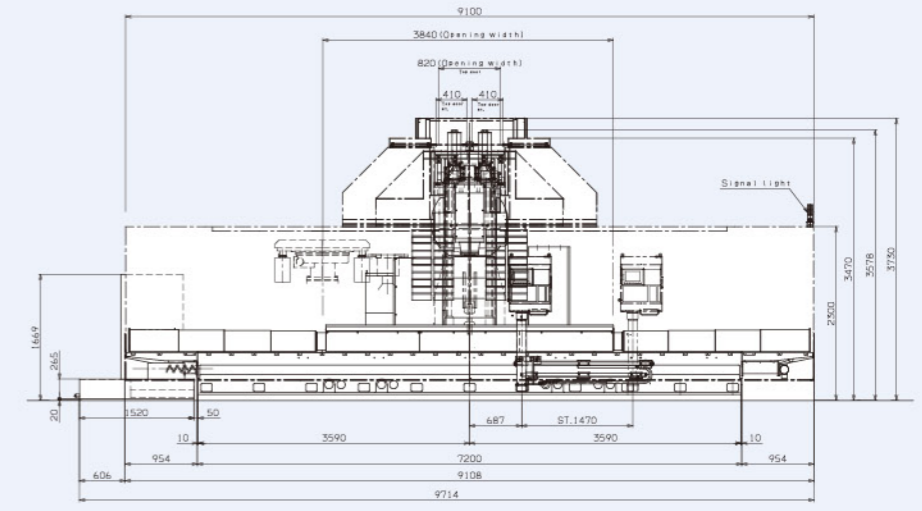

Floor space

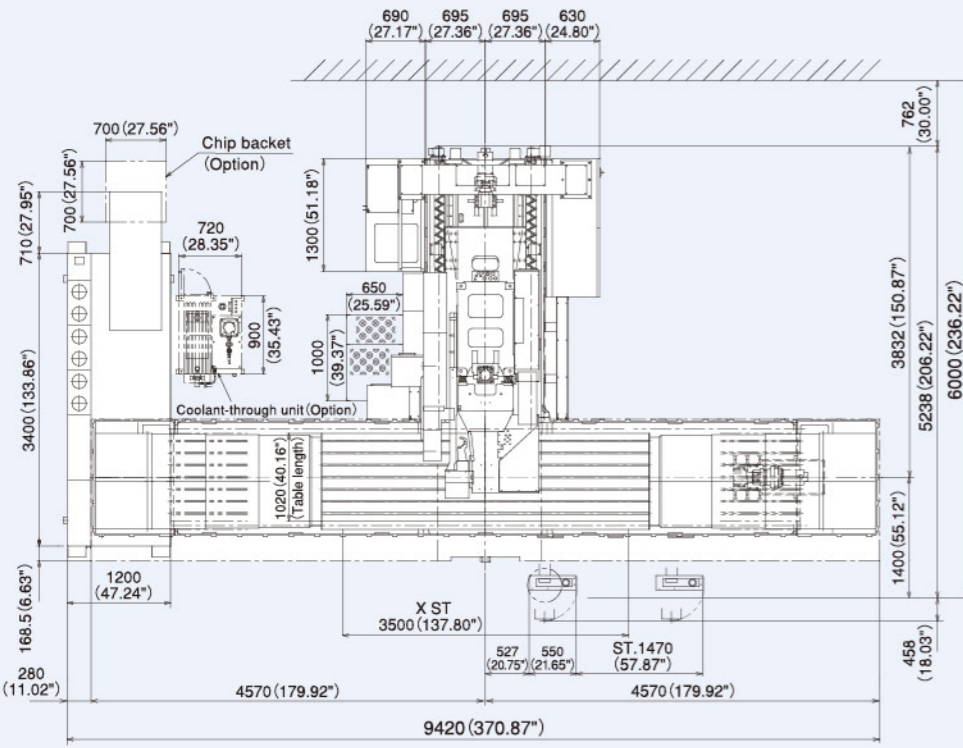

Table

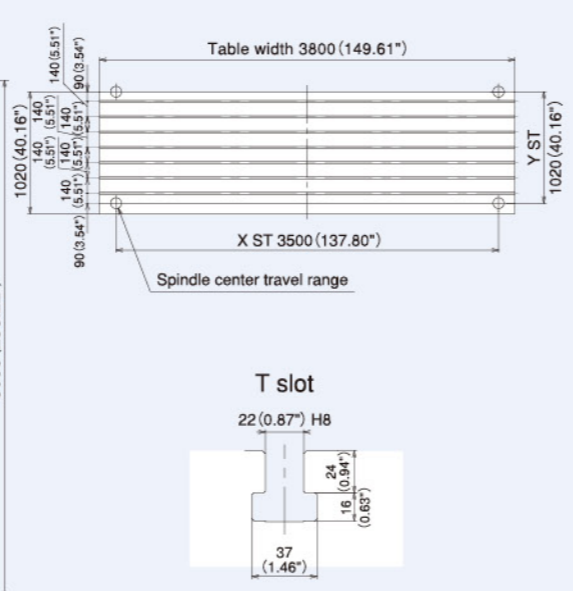

Floor space

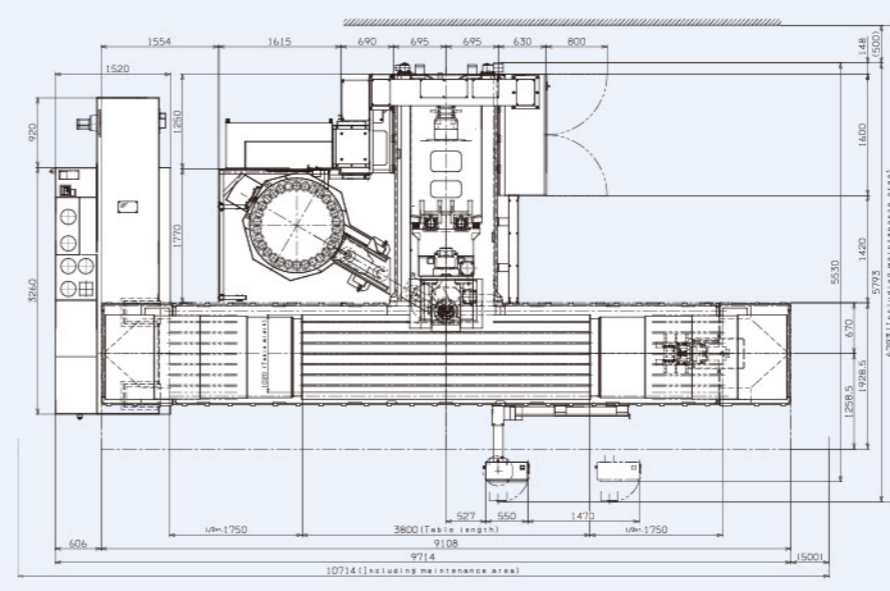

Table

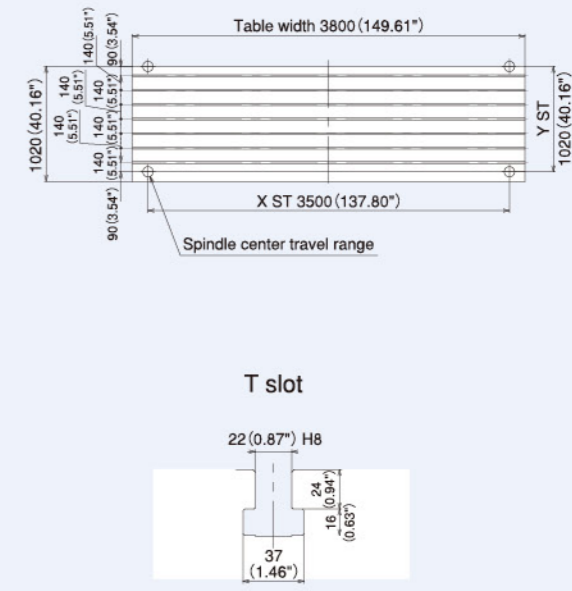

## Neomatic 830 (Windows 8-installed Open CNC)

### Standard Specification

No. of controlled axes: 3 axes (X, Y, Z)  
 No. of simultaneously controlled axes: 3 axes  
 Least input increment: 0.001 mm / 0.0001"  
 Max. programmable dimension:  
 ±99999.999 mm / ±9999.9999"  
 Inch / Metric conversion: G20 / G21  
 Program format:  
 Meldas standard format (M2 / M0 format needs to be instructed separately.)  
 Decimal point input I / II  
 Absolute / Incremental programming: G90 / G91  
 Program code: ISO / EIA automatic discrimination  
 Least control increment: 1nm  
 Positioning: G00  
 Linear interpolation: G01  
 Circular interpolation:  
 G02 / G03 (Including radius designation)  
 Unidirectional positioning  
 Helical interpolation  
 Cutting feed rate: 5.3-digit F-code, direct designation  
 One digit F-code feed  
 Rapid traverse override: 0 / 1 / 10 / 25 / 50 / 100%  
 Cutting feed rate override: 0 to 200% (every 10%)  
 Feed rate override cancel: M49 / M48 (cancel)  
 Rigid tap cycle: G74, G84  
 Manual handle feed:  
 Least input increment: X1, X10, X100 / graduation  
 Dwell: G04  
 Part program storage capacity: 1280m [500KB]  
 No. of registered programs: 1000  
 Part program editing  
 Background editing:  
 Possible to program or edit the machining program while NC machining is executed.  
 Buffer modification  
 Color touch-panel display  
 (15" LCD / QWERTY key MDI)  
 Integrating time display  
 Clock function  
 User definable key  
 MDI (Manual Data Input) operation  
 Menu list  
 Parameter / Operation guidance  
 Alarm guidance  
 Ethernet interface  
 SD card / USB memory interface  
 Operation inside display unit with high-speed program server  
 Operation with SD card / USB memory  
 Spindle function: Direct designation of spindle speed with 5-digit S-code  
 Spindle speed override: 50 to 150% (every 5%)  
 Tool function: Direct designation of called tool number with 4-digit T-code  
 ATC tool registration  
 Miscellaneous function:  
 Designation with 3-digit M-code  
 Multiple M-codes in 1 block: Maximum 3 codes in 1 block (Maximum 20 settings)  
 Tool length offset: G43, G44, G49 (cancel)  
 Tool position offset: G45 to G48  
 Cutter compensation: G38 to G42  
 Tool offset sets: Total 200 sets

Tool offset memory II :  
 tool geometry (length / diameter) and wear offset  
 Machine coordinate system: G53  
 Coordinate system setting: G92  
 Automatic coordinate system setting  
 Workpiece coordinate system: G54 to G59  
 Local coordinate system: G52  
 Manual reference position return  
 Automatic reference position return  
 2nd to 4th reference position return: G30 P2 to P4  
 Reference position return check: G27  
 Optional block skip: /n(n:1 to 9)  
 Single block  
 Dry run  
 Machine lock  
 Z-axis feed cancel  
 Miscellaneous function lock  
 3D solid program check  
 Graphic display check  
 Program number search  
 Sequence number search  
 Sequence number comparison and stop  
 Program restart function  
 Cycle start  
 Feed hold  
 Manual absolute  
 (ON / OFF setting with PLC parameter)  
 Auto restart  
 Program stop: M00  
 Optional stop: M01  
 Machining time computation  
 Automatic operation handle interruption  
 Manual numerical command  
 Sub program control: M98, M99  
 Canned cycle:  
 G73, G74, G76, G81 to G89, G80 (Cancel)  
 Linear angle designation  
 Circular cutting: G12, G13  
 Parameter mirror image  
 Programmable mirror image: G51.1, G50.1 (Cancel)  
 User macro and user macro interruption  
 Variable command: total 700 sets  
 Programmable coordinate system rotation:  
 G68, G69 (Cancel)  
 Parameter coordinate system rotation  
 Corner chamfering / corner R:  
 Insert between straight line-straight line / straight line-circle blocks  
 Programmable data input: G10 / G11 (Cancel)  
 Automatic corner override  
 Exact stop check / mode  
 Playback  
 Memory pitch error compensation  
 Backlash compensation  
 Skip function: G31  
 Manual tool length measurement  
 Tool life management II : 200 sets  
 External search  
 Emergency stop  
 Data protection key  
 NC alarm display  
 Machine alarm message  
 Stored stroke limit I / II  
 Load monitor

Self-diagnosis  
 Absolute position detection

### Optional Specification

Additional one axis control:  
 name of axis (A, B, C, U, V, W)  
 Additional two axes control:  
 name of axis (A, B, C, U, V, W) **Note**  
 Simultaneously controlled axes: 4 axes  
 Simultaneously controlled axes: 5 axes **Note**  
 Least input increment: 0.0001 mm / 0.00001 inch  
 Program format: M2 / M0 format  
 Spiral / Conical interpolation  
 Cylindrical interpolation  
 Hypothetical axis interpolation  
 NURBS interpolation  
 (Hyper HQ control mode II is required)  
 Handle feed 3 axes:  
 Standard pulse handle is removed.  
 Inverse time feed  
 Part program storage capacity: 2560m [1MB]  
 (No. of registered programs: total 1000)  
 Part program storage capacity: 5120m [2MB]  
 (No. of registered programs: total 1000)  
 RS232C interface: RS232C-1CH  
 Computer link B: RS232C  
 Spindle contour control (Spindle position control)  
 3-dimensional cutter compensation  
 Tool offset sets: total 400 sets  
 Tool offset sets: total 999 sets  
 Addition of workpiece coordinate system  
 (total 96 sets): G54.1 P1 to G54.1 P96  
 Addition of workpiece coordinate system  
 (total 300 sets): G54.1P1 to G54.1 P300  
 Tool retract and return  
 Scaling: G51, G50 (Cancel)  
 Pattern rotation  
 Chopping function  
 Special canned cycles: G34, G35, G36, G37  
 Additional tool life management sets: total 400 sets  
 Additional tool life management sets: total 999 sets

### Original Nidec OKK Software

Integrated machining support system ..... STD  
 Tool support ..... STD  
 Program Editor ..... STD  
 EasyPRO ..... STD  
 Work Manager ..... Opt  
 HQ control ..... STD  
 Hyper HQ control mode I ..... Opt  
 Hyper HQ control mode II ..... Opt  
 Soft Scale II m ..... STD  
 WinGMC8 (Including option H) ..... STD  
 Cycle Mate ..... Opt  
 Touch sensor T0 software ..... Opt  
 Soft CCM (Tool failure detection system) ..... Opt  
 Soft AC (Adaptive control unit) ..... Opt  
 Automatic restart at tool damage ..... Opt

Note: N850 (Windows 8-installed Open CNC)  
 STD: Standard Opt: Option

## F31i-B Plus (WindowsCE-installed Open CNC)

### Standard Specification

No. of controlled axes: 3 axes (X, Y, Z)  
 No. of simultaneously controlled axes: 3 axes  
 Least input increment: 0.001mm / 0.0001"  
 Max. programmable dimension:  
 +999999.999mm/+39370.0787"  
 Absolute / Incremental programming: G90 / G91  
 Decimal point input/Pocket calculator type decimal point input  
 Inch/ Metric conversion: G20 / G21  
 Program code: ISO / EIA automatic discrimination  
 Program format: FANUC standard format  
 FS15 tape format  
 Nano Interpolation (Internal)  
 Positioning: G00  
 Linear Interpolation: G01  
 Circular Interpolation: G02 / G03 (CW/CCW)  
 (Including radius designation)  
 Helical interpolation  
 Unidirectional positioning: G60  
 Cutting feed rate: 6.3-digit F-code, direct designation  
 Rapid traverse override: 0/1/10/25/50 / 100%  
 Cutting feed rate override: 0 to 200% (every 10%)  
 Feed rate override cancel: M49/M48  
 Rigid tapping: G84, G74 (Mode designation: M29)  
 Manual handle feed:  
 Least Input Increment X1, X10, X100/graduation  
 Dwell: G04  
 One-digit F code feed  
 Inverse time feed  
 Part program storage capacity: total 10240m [4MB]  
 (total 1000 programs)  
 Part program editing  
 Background editing:  
 Possible to program or edit the machining program while NC machining is executed.  
 Extended part program editing  
 15-Inch color LCD/QWERTY key MDI  
 Clock function  
 MDI (manual data input) operation  
 Run hour and parts count display  
 Memory card/USB interface  
 Spindle function: Direct designation of spindle speed with 5-digit S-code  
 Spindle speed override: 50 to 150% (every 5%)  
 Tool function: Direct designation of called tool number with 4-digit T-code  
 ATC tool registration  
 Auxiliary function: Designation with 3-digit M-code  
 Multiple M-codes in 1 block: Maximum 3 codes in 1 block (Maximum 20 settings)  
 Tool length offset: G43, G44 / G49  
 Tool diameter and cutting edge R compensation:  
 G41, G42/ G40  
 Tool offset sets: total 400 sets  
 Tool offset memory C  
 Tool position offset  
 Automatic reference position return: G28 / G29  
 2nd reference position return: G30  
 Machine coordinate system: G53  
 Coordinate system setting: G92  
 Automatic coordinate system setting  
 Workpiece coordinate system:  
 G54 to G59 G54.1 P1 ~ P48

Local coordinate system: G52  
 Polar coordinate command: G15,G16  
 Manual reference position return  
 Reference position return check: G27  
 Optional block skip:/  
 Single block  
 Dry run  
 Machine lock  
 Z-axis feed cancel  
 Auxiliary function lock  
 Graphic function  
 Program number search  
 Sequence number search  
 Program restart  
 Cycle start  
 Feed hold  
 Manual absolute (ON/OFF with PMC parameter)  
 Auto restart  
 Program stop: M00  
 Optional stop: M01  
 Sequence number collation and stop  
 Sub program control  
 Canned cycle: G73, G74, G76, G80 to G89  
 Mirror image function parameter  
 Custom macro  
 Programmable mirror image  
 Programmable data input: G10  
 Automatic corner override  
 Manual Guide i (Basic)  
 Exact stop check / mode  
 Scaling: G50,G51  
 Additional custom macro common variables:1000  
 Coordinate system rotation:G68,G69  
 Optional chamfering / corner R  
 Playback  
 Interpolation type pitch error compensation  
 Backlash compensation for each rapid traverse and cutting feed  
 Smooth backlash  
 Skip function  
 Tool life management: total 256 sets  
 Tool length manual measurement  
 Data protection key  
 NC alarm display / alarm history display  
 Machine alarm display  
 Stored stroke check 1  
 Stored stroke check 2  
 Load monitor  
 Self-diagnosis  
 Absolute position detection

### Optional Specification

Additional one axis control:  
 name of axis (A, B, C, U, V, W)  
 Additional two axes control:  
 name of axis (A, B, C, U, V, W) **Note 1**  
 No. of simultaneously controlled axes: 4 axes  
 No. of simultaneously controlled axes: 5 axes **Note 1**  
 Least input increment: 0.0001mm / 0.00001"  
 Spiral / Conical interpolation  
 Cylindrical interpolation  
 Hypothetical axis interpolation  
 Involute interpolation  
 NURBS interpolation

Smooth interpolation  
 (Hyper HQ control B mode is required)  
 Handle feed 3 axes:Standard pulse handle is removed  
 Part program storage capacity:  
 total 20480m [8MB] (1000 in total)  
 Machining time stamp  
 Data server: ATA card (1GB)  
 Machine lock  
 RS232C interface: RS232C-1CH  
 Spindle contour control (Cs contour control)  
 Tool offset sets: total 499 sets  
 Tool offset sets: total 999 sets  
 Addition of workpiece coordinate system  
 (total 300 sets): G54.1 P1 to P300  
 Optional block skip: Total 9  
 Manual handle interruption  
 Tool retract and return  
 Figure copy  
 Interruption type custom macro  
 Instruction of inclined plane indexing  
 Chopping  
 Manual Guide i (Milling cycle)  
 Addition of tool life management sets: total 1024 sets  
 High-speed skip

### Original Nidec OKK Software

Integrated machining support software  
 (incl. help guidance, etc.) ..... STD  
 Tool support ..... STD  
 Program Editor ..... STD  
 EasyPRO ..... STD  
 Work Manager ..... Opt  
 HQ control ..... STD  
 Hyper HQ control mode A ..... Opt  
 Hyper HQ control mode B ..... Opt  
 Hyper HQ varue kit Note 2 ..... Opt  
 Special canned cycle  
 (including circular cutting) ..... Opt  
 Cycle Mate F ..... Opt  
 Soft Scale II m ..... STD  
 Touch sensor T0 software ..... Opt  
 Soft CCM (Tool failure detection system) ..... Opt  
 Soft AC (Adaptive control unit) ..... Opt  
 Automatic restart at tool damage ..... Opt

Note 1: F31i-B5 Plus (WindowsCE-installed Open CNC)  
 Note 2: Includes Data server: ATA card (1GB) and Hyper HQ control mode B  
 STD: Standard Opt: Option

## F30i-B Plus (WindowsCE-installed Open CNC)

### Standard Specification

No. of controlled axes: 5 axes (X, Y, Z, A, B)  
 No. of simultaneously controlled axes: 5 axes  
 Least input increment: 0.001mm / 0.0001"  
 Max. programmable dimension:  
 ±999999.999mm / ±39370.0787"  
 Absolute / Incremental programming: G90 / G91  
 Decimal point input /  
 Pocket calculator type decimal point input  
 Inch / Metric conversion: G20 / G21  
 Program code: ISO / EIA automatic discrimination  
 FS15 program format switching function  
 Nano interpolation (internal)  
 Positioning: G00  
 Linear interpolation: G01  
 Circular interpolation: G02 / G03 (CW / CCW)  
 (Including radius designation)  
 Helical interpolation  
 Single direction positioning  
 Cutting feed rate: 6.3-digit F-code, direct designation  
 Dwell: G04  
 One-digit F code feed  
 Inverse time feed  
 Part program storage length: 10,240m [4Mbyte]  
 (Possible to extend optionally.)  
 Manual handle feed:  
 Least input increment ×1, ×10, ×100 / graduation  
 Rapid traverse override: 0 / 1 / 10 / 25 / 50 / 100%  
 Cutting feed rate override: 0 to 200% (every 10%)  
 Feed rate override cancel: M49 / M48  
 Rigid tapping: G84, G74 (Mode designation: M29)  
 Part program editing  
 Background editing:  
 Possible to program or edit the machining program  
 while NC machining is executed.  
 Extended part program editing  
 15-inch color LCD / QWERTY key MDI  
 Clock function  
 MDI (manual data input) operation  
 Run hour and parts count display  
 Memory card / USB interface  
 Spindle function: Direct designation of spindle speed  
 with 5-digit S-code  
 Spindle speed override: 50 to 150% (every 5%)  
 Tool function: Direct designation of called tool  
 number with 4-digit T-code  
 ATC tool registration  
 Auxiliary function: Designation with 3-digit M-code  
 Multiple M-codes in 1 block: Maximum 3 codes in  
 1 block (Maximum 20 settings)  
 Tool length offset: G43, G44 / G49  
 Tool diameter and cutting edge R compensation:  
 G41, G42 / G40  
 Tool offset pairs : Total 400 pairs  
 (Extension is possible optionally.)  
 Tool offset memory C  
 Tool offset  
 Manual reference position return  
 Automatic reference position return: G28 / G29  
 2nd reference position return: G30  
 Reference position return check: G27  
 Automatic coordinate system setting  
 Coordinate system setting: G92

Machine coordinate system: G53  
 Workpiece coordinate system: G54 to G59  
 Addition of workpiece coordinate system  
 (total 48 sets): G54.1 P1 to P48  
 Local coordinate system: G52  
 Polar coordinate command : G15, G16  
 Program stop: M00  
 Optional stop: M01  
 Optional block skip: /  
 Dry run  
 Machine lock  
 Z-axis feed cancel  
 Auxiliary function lock  
 Program number search  
 Sequence number search  
 Program restart  
 Cycle start  
 Auto restart  
 Single block  
 Feed hold  
 Manual absolute (ON / OFF with PMC parameter)  
 Sub program control  
 Canned cycle: G73, G74, G76, G80 to G89  
 Mirror image function parameter  
 Automatic corner override  
 Exact stop check / mode  
 Scaling  
 Addition of custom macro common variables 1000  
 Coordinate system rotation: G68, G69  
 Optional chamfering/corner R  
 Playback  
 Interpolation type pitch error compensation  
 Programmable data input: G10  
 Programmable mirror image  
 Custom macro  
 Graphic function  
 Backlash compensation for each rapid traverse and  
 cutting feed  
 Smooth backlash  
 Interpolation type pitch error compensation  
 Skip function  
 Tool length manual measurement  
 Tool life management: total 256 sets  
 Emergency stop  
 Data protection key  
 NC alarm display / alarm history display  
 Machine alarm display  
 Stored stroke check 1  
 Stored stroke check 2,3  
 (3: For the interference area preset by the manufacturer)  
 Load monitor  
 Self-diagnosis  
 Absolute position detection  
 Manual Guide i (Basic)  
 Tool center point control for 5 axis machining  
 Inverse time feed  
 Data server: ATA card (1GB)  
 Instruction of inclined plane indexing  
 (Instruction of inclined plane machining)  
 Manual feed for 5-axis machining  
 Tool length compensation along tool vector  
 Straightness compensation  
 3-dimensional coordinate system conversion

### Optional Specification

Least input increment: 0.0001mm / 0.00001"  
 Cylindrical interpolation  
 Hypothetical axis interpolation  
 Spiral / Conical interpolation  
 Smooth interpolation  
 (Hyper HQ control B mode is required)  
 NURBS interpolation  
 (Hyper HQ control B mode is required)  
 Involute interpolation  
 One-digit F code feed  
 Handle feed 3 axes: Standard pulse handle is removed  
 Part program storage capacity:  
 total 20480m [8MB] (1000 in total)  
 RS232C interface: RS232C-1CH  
 Data server: ATA card (4GB)  
 Spindle contour control (Cs contour control)  
 Tool position offset  
 3-dimensional cutter compensation  
 Smooth TCP  
 Tool offset sets: total 499 sets  
 Tool offset sets: total 999 sets  
 Addition of workpiece coordinate system  
 (total 300 sets): G54.1 P1 to P300  
 Machining time stamp  
 Optional block skip: Total 9  
 Tool retract and return  
 Manual handle interruption  
 Interruption type custom macro  
 3-dimensional coordinate system conversion  
 Figure copy  
 Chopping  
 Addition of tool life management sets: total 1024 sets  
 High-speed skip  
 Manual Guide i (Milling cycle)

### Original Nidec OKK Software

Integrated machining support software  
 (incl. help guidance, etc.) ..... STD  
 Tool support ..... STD  
 Program Editor ..... STD  
 EasyPRO ..... STD  
 Work Manager ..... Opt  
 HQ control ..... STD  
 Hyper HQ control mode B ..... Opt  
 Special canned cycle  
 (including circular cutting) ..... Opt  
 Cycle Mate F ..... Opt  
 Touch sensor T0 software ..... Opt  
 Soft CCM (Tool failure detection system) ..... Opt  
 Soft AC (Adaptive control unit) ..... Opt  
 Automatic restart at tool damage ..... Opt

Note: F31i-B5 (Windows CE-installed Open CNC)  
 STD: Standard Opt: Option

## 5-axis Machining Support Technologies

## KCV1000-5AX

### 5-axis Control Function

#### Tool Center Point (TCP) Control

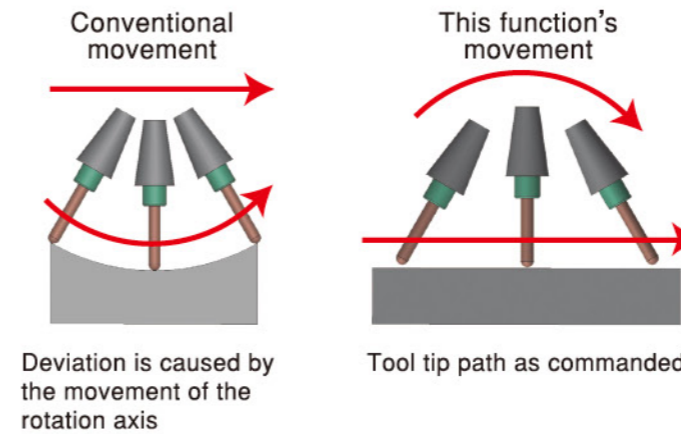

Normally the linear interpolation while changing the tool posture requires the commands for the changes in the tool shaft direction in accordance with the changes in the angle of the tool posture. Thus, the relevant machining data using minute line segments become complicated.

With the Tool Center Point (TCP) control, the tool tip path is as commanded regardless of the commands for the rotation axis. As the speed of the tool tip is constant (the commanded speed), high-quality surfaces can be achieved.

### 5-axis Indexing Function

#### Inclined Surface Indexing (Machining) Command (Option)

The inclined surface indexing (machining) commands allow defining flexibly the surface to be machined by setting a new coordinate system (feature coordinate system) so that the machining programs can be created efficiently similarly to the ones for the normal 3-axis machining centers.

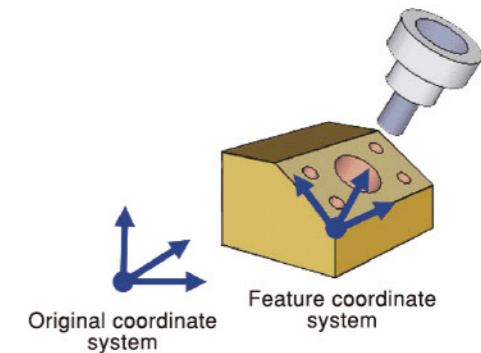

#### MULTI-FACER II

At the time of indexing the surface to be machined with the 5-axis machining center, it may take time to set the workpiece origin. MULTI-FACER II makes it possible to create the programs for indexing easily without using calculators and to set the workpiece origin easily.





## **NIDEC OKK CORPORATION**

**8-10, KITA-ITAMI, ITAMI  
HYOGO 664-0831 JAPAN**  
International Sales Department  
TEL: (81)72-771-1143  
[www.nidec.com/en/nidec-okk/](http://www.nidec.com/en/nidec-okk/)  
E-mail: [nokk.ovsd@nidec.com](mailto:nokk.ovsd@nidec.com)

### **NIDEC OKK A DIVERSIFIED MANUFACTURER OF MACHINE TOOLS**

#### **Specializes In:**

Machining centers  
Graphite cutting machining centers  
Grinding centers  
CNC Milling machines  
Conventional milling machines  
Total die and mold making systems  
Flexible manufacturing cells and systems

#### **NOTE :**

NIDEC OKK reserves the right to change the information contained in this brochure without notice.  
NIDEC OKK is not responsible to make changes to previously sold machines or accessories.  
The machines in the photographs of this brochure may include optional accessories.

The export of this product is subject to an authorization from the government of the exporting country.  
Check with the government agency for authorization.

#### **NIDEC OKK USA CORPORATION**

101 South Gary Avenue, Suite B, Roselle, IL 60172, U.S.A  
TEL: (1)630-924-9000

#### **NIDEC OKK Europe GmbH**

HANSEMANNSTR 33 41468 NEUSS, GERMANY  
TEL: (49)2131-29868-0  
FAX: (49)2131-29868-41

#### **NIDEC OKK Machinery (THAILAND) Co., Ltd.**

KUMTHORN HOLDING BUILDING 2nd FLOOR 897-897/1 Rama 3  
Road, Bangpongpan, YANNAWA, BANGKOK 10120 THAILAND  
TEL: (66)2-683-2160-2  
FAX: (66)2-683-2163

#### **NIDEC OKK (SHANGHAI) CO., LTD.**

12F, TOWER B, 100 ZUNYI ROAD, CHANG NING DISTRICT,  
SHANGHAI, CHINA  
TEL: (86)21-62700930  
FAX: (86)21-62700931