

NTRX-300/300L

NAKAMURA-TOME
PRECISION INDUSTRY CO.,LTD.

NTRX-300

Multitasking Machining Robot with ATC



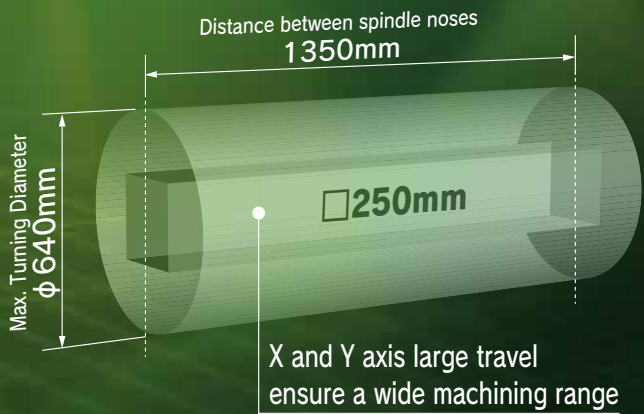

Innovation Technology
Creating Value

Nakamura-Tome





NTRX-300L

Multitasking Machining Robot with ATC

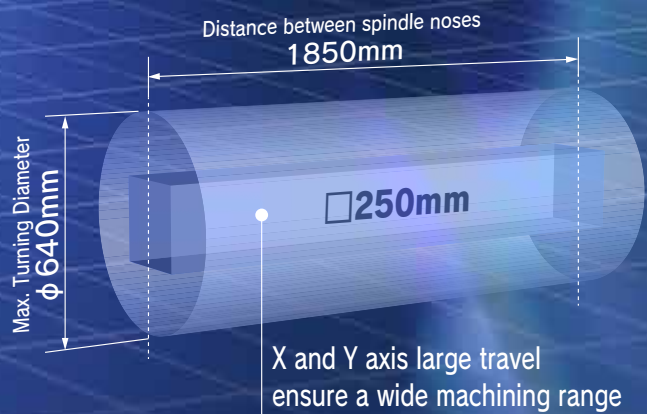

From Individual Processes to Consolidated Processes.

Complete Part Machined in One



● Feature 1

X and Y axis travel ensure a wide machining range.

NTRX-300 NTRX-300L

Refer to p.8-9



● Feature 2

Long-tool ATC (Option)

NTRX-300L

Refer to p.10



● Feature 3

NC Steady Rest (Option)

NTRX-300L

Refer to p.10



● Feature 4

Machine Condition Color Visualization

NTRX-300L

Refer to p.10

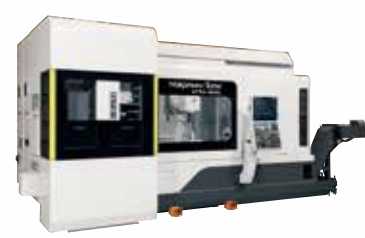

Operation.



● Feature 5

Short Type Tool Spindle

NTRX-300 NTRX-300L

Refer to p.9



● Feature 6

Operator friendly design

NTRX-300 NTRX-300L

Refer to p.11



● Feature 7

Highly Rigid Design

NTRX-300 NTRX-300L

Refer to p.13-14



● Feature 8

New operation panel with NT Smart X featuring

NTRX-300 NTRX-300L

Refer to p.17-22



- X-axis travel 125mm below spindle center ensures

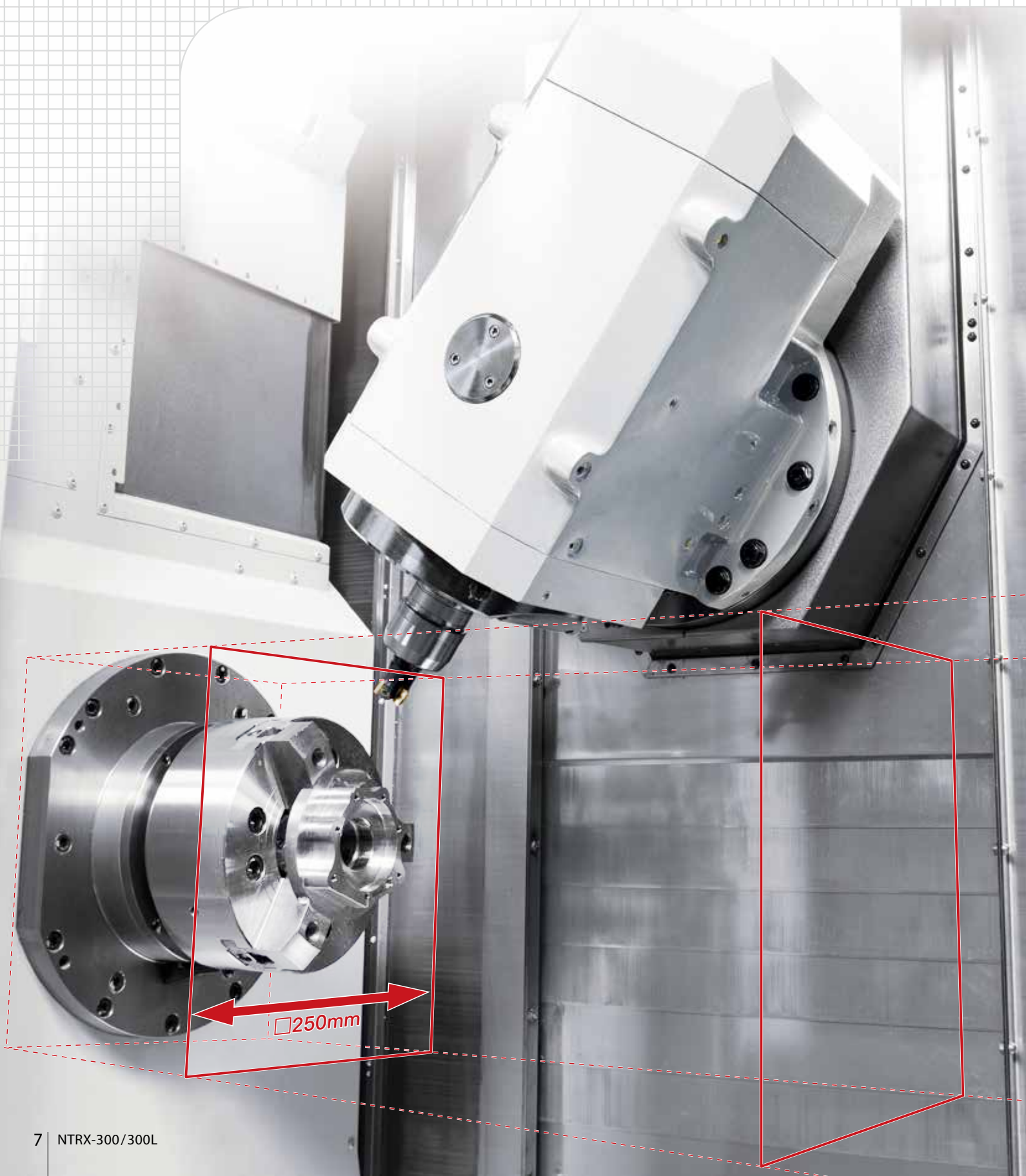

a wider machining range.



- Wide range machining area thanks to large X-axis and Y-axis travel.

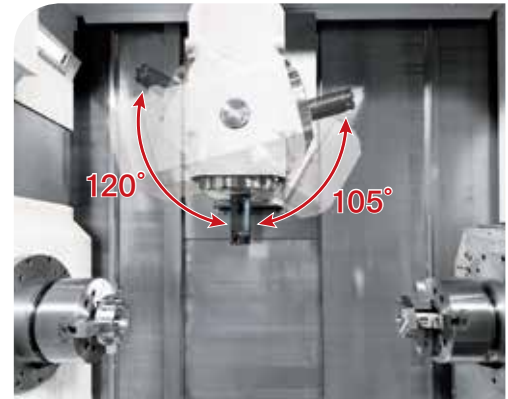
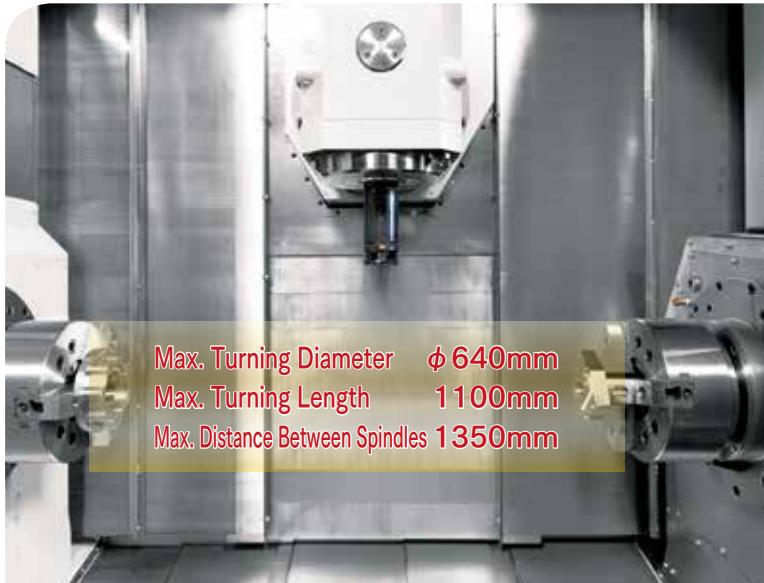

■ B-axis swiveling range
225° (-120° +105°)

■ Y-axis travel
250mm
(±125mm)

X-axis max. travel is 125mm beyond spindle center. Y-axis travel is ±125mm from the spindle center. This helps achieve high-precision milling or drilling without repositioning the C-axis.

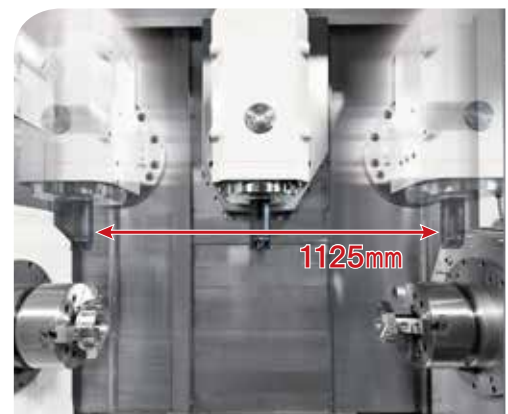
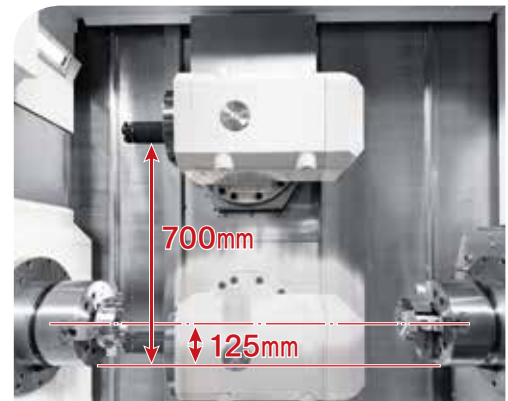

■ X1 / Z1 / B2 - axis travel
700 / 1125 / 1100mm

One hit machining



● Wide machining range and long tool operations thanks to 1850

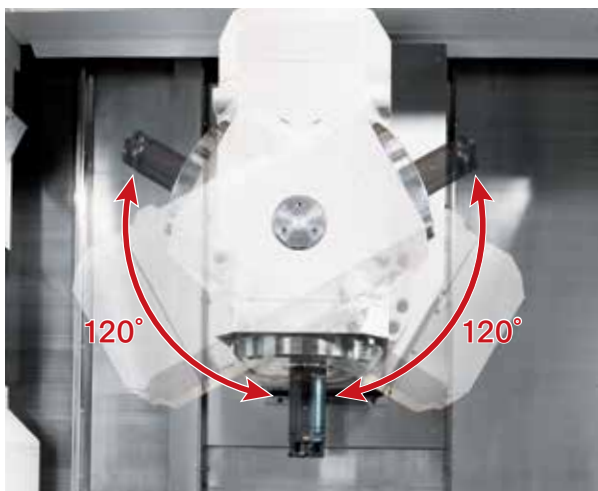

■ B-axis swiveling range
240° (±120°)

■ Y-axis travel
**250mm
(±125mm)**

X-axis max. travel is 125mm beyond spindle center. Y-axis travel is ±125mm from the spindle center. This helps achieve high-precision milling or drilling without repositioning the C-axis.

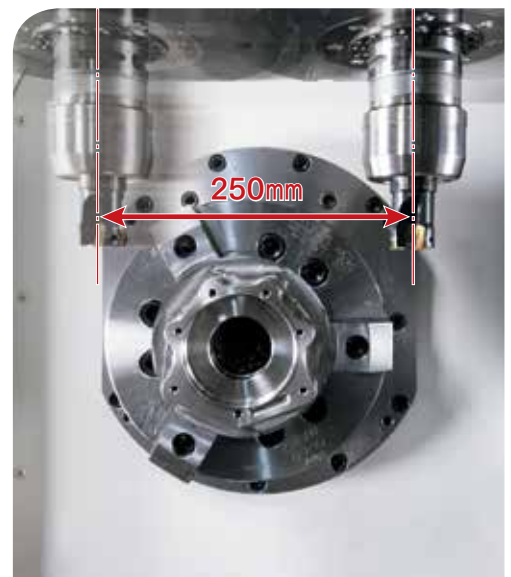

0 mm distance between spindle-noses.



Short type tool spindle specification

● Operator friendly features!



Long Tool ATC (op.)

Long Tool ATC is optionally available. Up to three (3) long tools can be used. (Max. length 450mm, Max. Diameter 65mm, Max. weight 12kg)



NC Steady Rest

Type A (diameter 20-165mm) or B (diameter 50-200mm) can be chosen. Pressure range 0.8-3.5Mpa. CNC servo-driven steady rest automatic positioning for maximum flexibility.



One hit machining

Color Visualization of Machine Condition

Machine condition is clearly visualized with 2 color LED lights on the machine front covers : Signal tower, load-meter, work-counter, ATC condition, ... etc. Displayed information can be set on NT- Smart X.





A Multitasking machine with full 5



Compact Design.

Spindle center is easy to reach, thanks to 450mm distance from the machine front and 1100mm height from the floor.



Easy ATC Tool Setup.

The ATC magazine is accessible from machine front, greatly improving tool setup. ATC with 40 tools is standard. (60, 80, 120 tools optional; field retrofittable).



Flexible Operation Panel

Operation panel can be adjusted in height within a range of 240mm up/down and rotated within an angle of 135°. A freely adjustable operation panel ensures the best comfort for the user.

-axis capabilities*, but simple operation functionality

* For 5-Axis machining, please talk to your sales representative about available options.



Large window to better see the machining area

The large-window made from two-tier glass ensures better visual access into machining area, and provides full protection for the operator along with the fortified front door. (CE conform).



One hit machining

Less floor space with compact design

NTRX-300 Floor space (included chiptank)

L 4,460mm × W 2,670mm × H 2,615mm

L 4,917mm × W 2,670mm × H 2,615mm (included chip conveyor & chiptank)

NTRX-300L Floor space (included chiptank)

L 5,440mm × W 2,677mm × H 2,615mm

L 5,744mm × W 2,677mm × H 2,615mm (included chip conveyor & chiptank)



Unique design of machine bed

● High Rigidity Design

Horizontal bed and vertical column structure

Low gravity design

The slides having a vertical column structure are mounted on a horizontal machine bed. During slide movement, the uniform load applied over the machine bed ensures stability over the whole machining range. The Y-axis full column movement, ensure wide machining range of 250mm (±125mm)

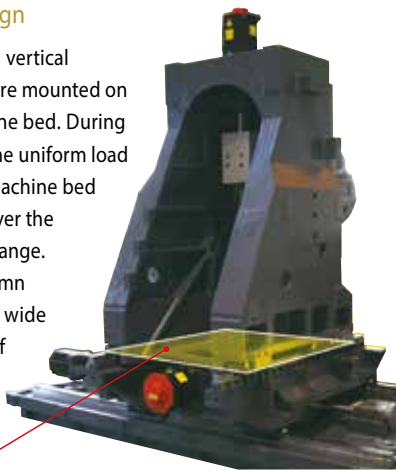

Wide and Deep Column base

Highly Rigid Tool Spindle

Highly rigid unit

The X-axis slide unit width and depth ensures that the tool spindle unit is mounted on a stable base.

Roller drive

The B1-axis roller drive adopting a preloaded bearing mechanism, achieves zero backlash and high precision positioning and ensures excellent rotation and high transmission accuracy.

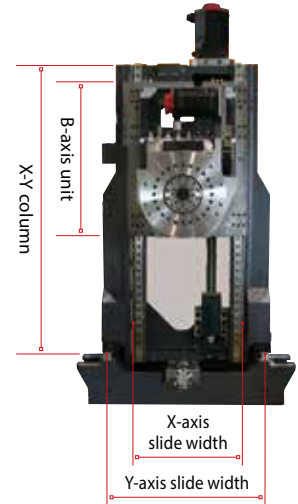

High Performance Automation System. (Op.)

Loading and Unloading grippers stored in the ATC magazine are used for automation. Blanks are picked up from an In-conveyor and finished parts are unloaded to an Out-Conveyor. Both conveyors are located at the top side of the R side spindle. A maximum of 13 parts (Max. Dia 90mm) can be stocked in one conveyor.

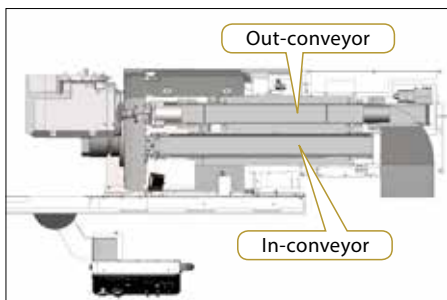

Specification

Workpiece size		Conveyor Capacity	
Diameter	φ50mm - φ90mm	Length of Conveyor	1335mm
Length	80mm - 150mm	Maximum Weight	
Weight	3kg	In-conveyor	39kg
		Out-conveyor	12kg

When work piece has special shape (Not round), hand jaws have to be modified.

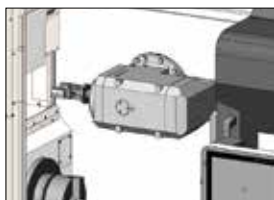

Call Up Loading gripper from ATC Magazine and load the blank from In-conveyor.

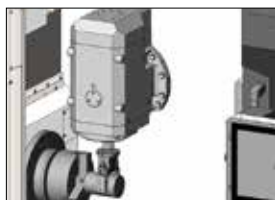

Loading
Loading the blank by using Loading gripper to the L-Spindle.



Unloading
Unload the finished parts to the Out-conveyor. Side by side : In-conveyor and Out-conveyor.

Superior 5-axis machining rigidity

High precision B-axis

With a reduced distance from tool tip to B-axis center of rotation, the B-axis resists to higher cutting torques and achieves stable machining.

Direct drive structure

The X, Y and Z-axis servo motors are directly mounted to the respective ball screws, ensuring a backlash-free high-speed smooth movement.



to maximize rigidity and thermal stability

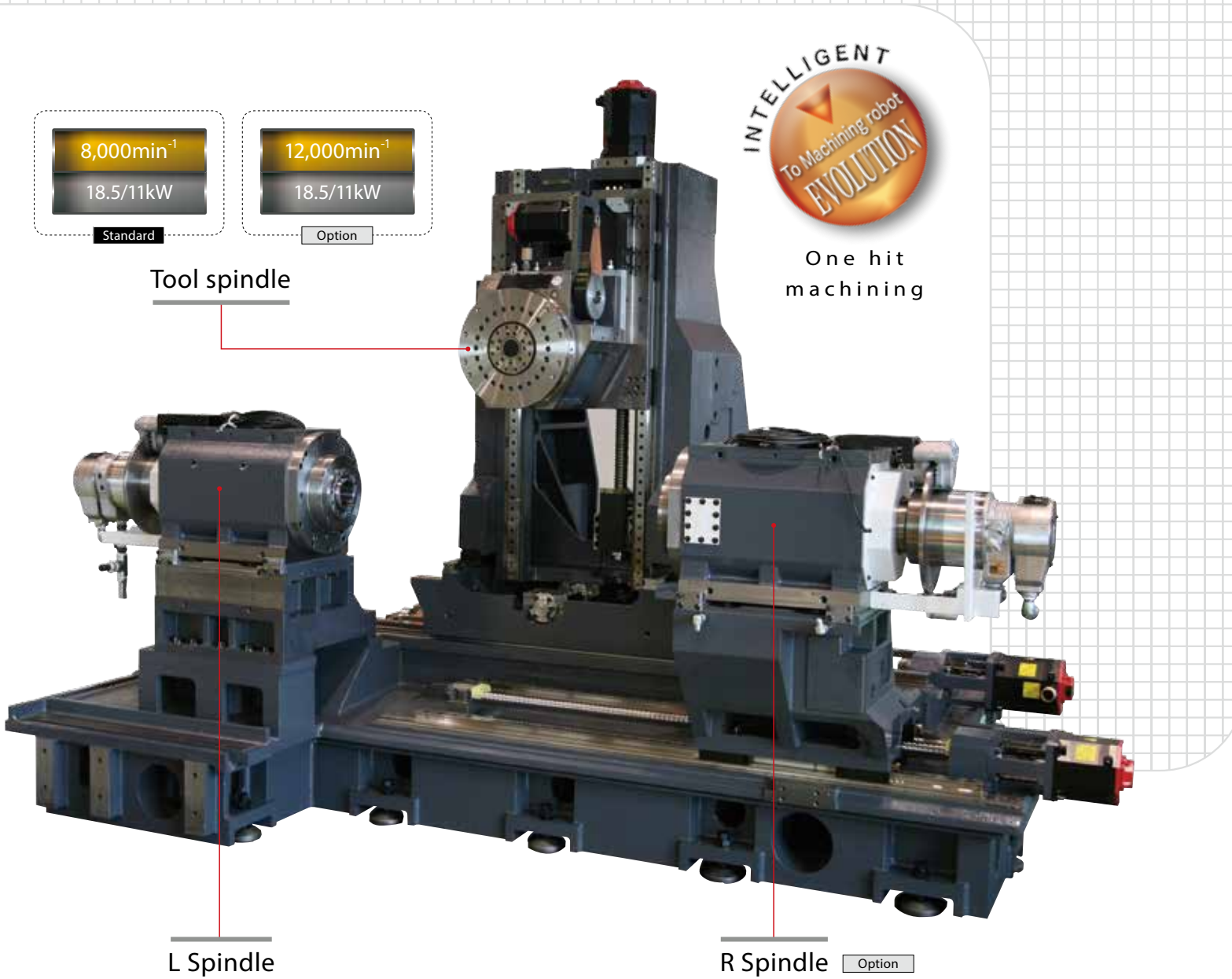

	Standard	Option	Option	Option	Option
L Spindle	Bar capacity $\phi 65\text{mm}$ 15/11kW 4,500min ⁻¹	Bar capacity $\phi 71\text{mm}$ 15/11kW 3,500min ⁻¹	*1 Bar capacity $\phi 80\text{mm}$ 22/18.5kW 3,500min ⁻¹	Bar capacity $\phi 80\text{mm}$ 22/18.5kW 2,500min ⁻¹	Bar capacity $\phi 90\text{mm}$ 22/18.5kW 2,500min ⁻¹
R Spindle	Bar capacity $\phi 65\text{mm}$ 15/11kW 4,500min ⁻¹	Bar capacity $\phi 71\text{mm}$ 15/11kW 3,500min ⁻¹	*1 Bar capacity $\phi 80\text{mm}$ 22/18.5kW 3,500min ⁻¹	Bar capacity $\phi 80\text{mm}$ 22/18.5kW 2,500min ⁻¹	Bar capacity $\phi 80\text{mm}$ 22/18.5kW 2,500min ⁻¹ 3,500min ⁻¹

Choice from R-spindle type or tailstock type

* 1. Direct connect type

● Modular design

■ R-spindle Specification

A ATC	B ₁ Tool spindle	Y Y-axis	
S _{x2} Twin-Spindle	C _{x2} C-axes	B ₂ R spindle	
19" Color LCD Touch Panel	NT Smart X	Tailstock not be selected with this option.	

■ Tailstock Specification

A ATC	B ₁ Tool spindle	Y Y-axis	
S Spindle	C C-axes	TS Tail stock	
19" Color LCD Touch Panel	NT Smart X	R-spindle not be selected with this option.	

**Choose from R-spindle
type or tailstock type**

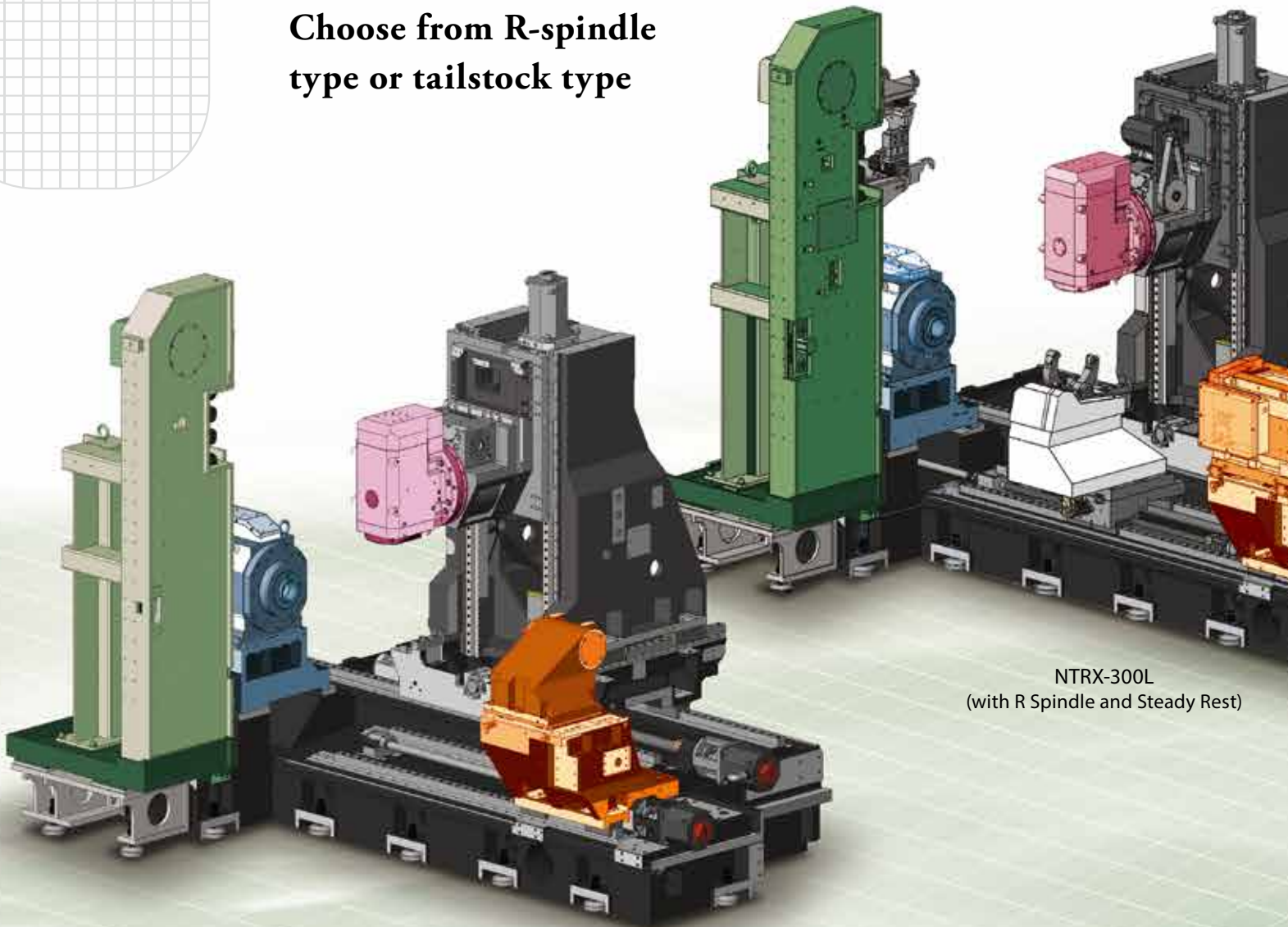

NTRX-300
(with Tailstock)

NTRX-300L
(with R Spindle and Steady Rest)



One hit machining

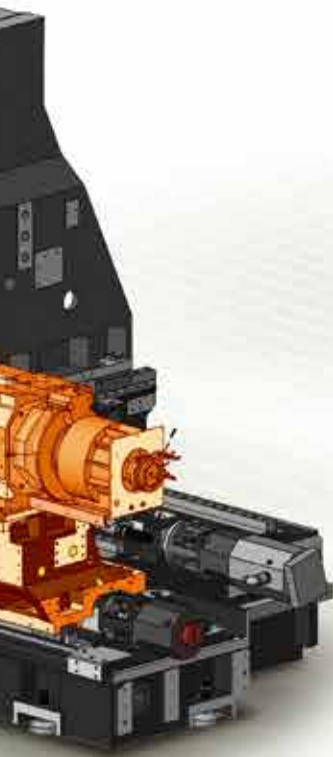

Capacity		NTRX-300					NTRX-300L				
Max. turning diameter / max. turning length		640mm / 1,100mm					640mm / 1,600mm				
Distance between spindles		max. 1,350mm / min. 250mm (Right Spindle Specification) max. 1,225mm / min. 125mm (Tail Stock Specification)					max. 1,850mm / min. 300mm (Right Spindle Specification) max. 1,796mm / min. 246mm (Tail Stock Specification) max. 1,850mm / min. 720mm (Steady Rest Specification) max. 1,796mm / min. 666mm (Tailstock / Steady Rest Specification)				
Bar capacity		L, R 65mm		L, R 71mm (op.)			L, R 65mm		L, R 71mm (op.)		
		L, R 80mm (op.)		L 90mm / R 80mm (op.)			L, R 80mm (op.)		L 90mm / R 80mm (op.)		
Chuck size		8" 210mm		10" 254mm			8" 210mm		10" 254mm		
Axis travel											
Slide travel (X1 / Z1 / B2)		700 / 1125 / 1100mm					700 / 1,625 / 1,550mm 1,015mm (Steady Rest Specification)				
Slide travel (Y)		250mm (±125mm)					250mm (±125mm)				
Spindle L											
		φ65	φ71 (op.)	φ80 (op.)		φ90 (op.)	φ65	φ71 (op.)	φ80 (op.)		φ90 (op.)
Spindle speed		4,500min ⁻¹	3,500min ⁻¹	3,500min ⁻¹	2,500min ⁻¹	2,500min ⁻¹	4,500min ⁻¹	3,500min ⁻¹	3,500min ⁻¹	2,500min ⁻¹	2,500min ⁻¹
Spindle nose		A2-6	A2-8	*1	A2-8	A2-8	A2-6	A2-8	*1	A2-8	A2-8
Spindle bearing ID		120mm	130mm	130mm	150mm	150mm	120mm	130mm	130mm	150mm	150mm
Main Spindle motor		15/11kW			22/18.5kW (op.)		15/11kW		22/18.5kW (op.)		
Spindle R (option)											
		φ65	φ71 (op.)	φ80 (op.)		φ90 (op.)	φ65	φ71 (op.)	φ80 (op.)		φ90 (op.)
Spindle speed		4,500min ⁻¹	3,500min ⁻¹	3,500min ⁻¹	2,500min ⁻¹	-	4,500min ⁻¹	3,500min ⁻¹	3,500min ⁻¹	2,500min ⁻¹	-
Spindle nose		A2-6	A2-8	*1	A2-8	-	A2-6	A2-8	*1	A2-8	-
Spindle bearing ID		120mm	130mm	130mm	150mm	-	120mm	130mm	130mm	150mm	-
Main Spindle motor		15/11kW			22/18.5kW		15/11kW		22/18.5kW		
Tailstock (option)											
Driving Methods		NC control servo driven					NC control servo driven				
Tailstock positioning stroke / Rapid feed rate		1,100mm / 8,000mm/min					1,550mm / 8,000mm/min				
Tailstock spindle taper size		MT-5 (built in center)					MT-5 (built in center)				
Ball screw diameter / Ball screw pitch		36mm / 10mm					36mm / 10mm				
Tailstock force		2.5 - 6.5kN					2.5 - 6.5kN				
Tool spindle											
Tool spindle speed / Tool spindle motor		8,000min ⁻¹ (op. 12,000min ⁻¹) / 18.5/11kW					8,000min ⁻¹ (op. 12,000min ⁻¹) / 18.5/11kW				
B-axis positioning range		225° (-120°, +105°)					240° (±120°)				
Tool shank type		HSK-A63 (op. CAPTO C6)					HSK-A63 (op. CAPTO C6)				
ATC											
ATC Number of tools		40 (op. 60, 80, 120)					40 (op. 60, 80, 120)				
Max. tool diameter / No adjacent tools		90mm / 130mm					90mm / 130mm				
Max. tool length / Max. tool weight		300mm / 12kg					300mm / 12kg				
Long tool (op.)	Number of Tools	-					3				
	Maximum diameter / length / weight	-					φ65mm / 450mm / 12kg				
General											
Floor space (L×W×H)		4,460mm × 2,670mm × 2,615mm (included chiptank)					5,440mm × 2,670mm × 2,615mm (included chiptank)				
		4,917mm × 2,670mm × 2,615mm (included chip conveyor & chiptank)					5,744mm × 2,670mm × 2,615mm (included chip conveyor & chiptank)				
Machine weight (incl.control)		17,000kg (For 40 Tools ATC)					19,000kg (For 40 Tools ATC)				

*1. Direct connect type (Without draw tube adaptor)

NT Smart *X*

Advanced Production System

- 3D Smart PRO
- Original Menu Screen
- Voice Guidance
- Multiple-Touch screen
- Windows 8



• 19 inch color LCD Touch panel • PC memory 8GB • QWERTY Key board • Windows 8 • Touch Pad • USB 2.0 port x 2

Program storage length	Total 512Kbyte (1,280m)	Total 1Mbyte (2,560m)	Total 2Mbyte (5,120m)	Total 24Mbyte (10,240m)	Total 28Mbyte (20,480m)
Program registered number	Total 1,000	Total 2,000	Total 4,000		

Standard / Option

Main features

- NT Manual Guide i
- NT Work Navigator
- Airbag (Overload detection)
- Advanced NT Nurse
- Status Display Function
- Setup Display
- Trouble Guidance
- Productivity Function
- Operation Level Control Function
- Warm up Function
- Built-in Loading Device Setting Screen (op.)
- Parts Catcher G Operation Function (op.)
- NT Machine Simulation
- NT Collision Guard
- NT Multitasking Office (op.)
- Net Monitor (op.)
- 3D Smart PRO



Cut-in Check

The machine can be stopped immediately while in automatic cycle. After reading G00 command in the machining program, the Spindle, Tool spindle, Axis Feeding and Coolant will stop. It is faster than M01 optional stop. After checking the machine internal status, the machining can be restarted by pressing "Program restart" button.

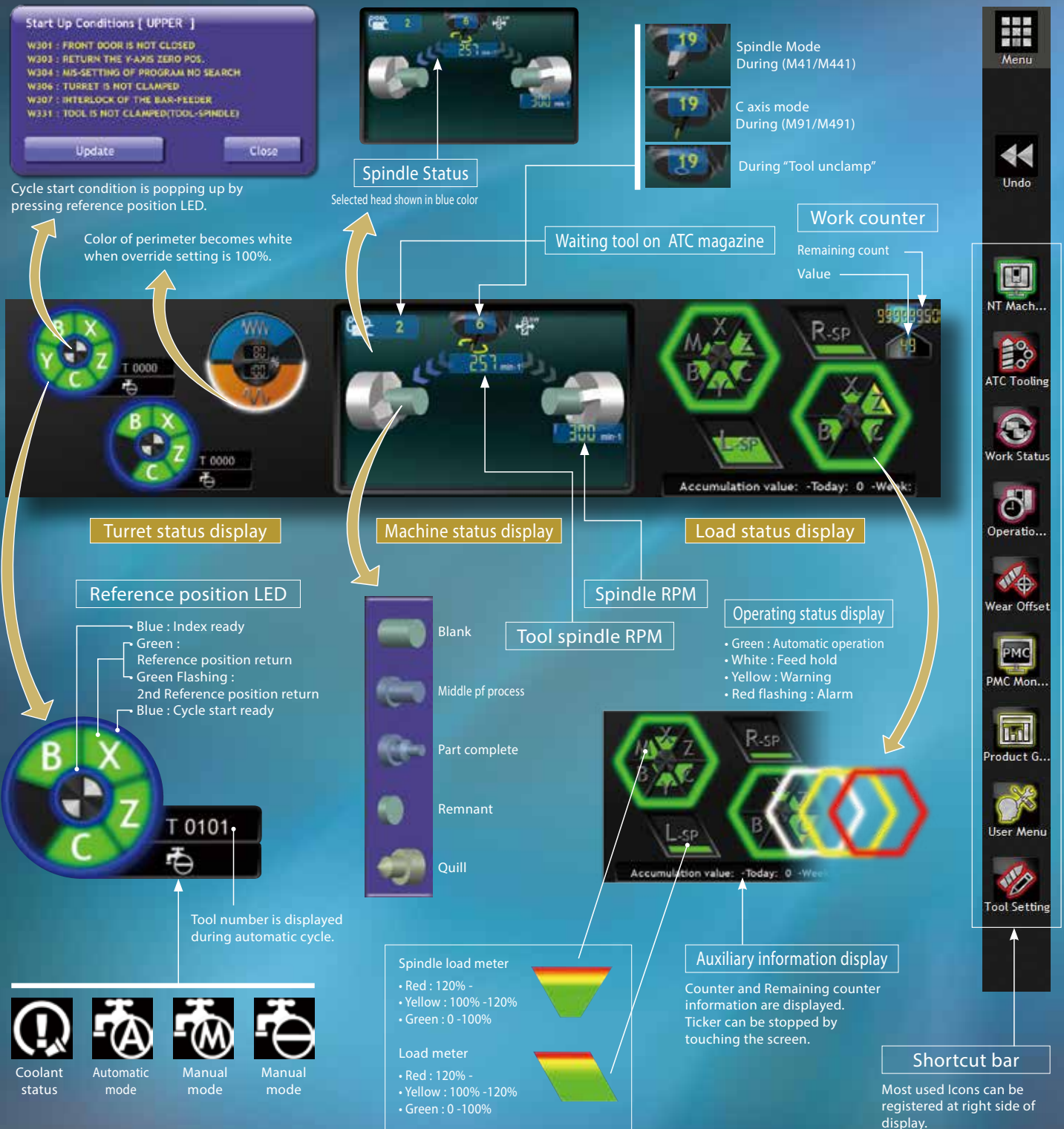

G131 Soft work pusher

This cycle is used during part transfer from left to right side spindle. Once part contact with the jaws or stopper of the right side spindle has been confirmed, the right side spindle servo axis stops.



- Contact force can be changed in the program.
- It is possible to set OK/ NG range as well.
- An additional work pusher for the right side is not required and cycle time can be reduced.

G376

Thrust force of center support can be set in the program by using servo motor technology, which helps keeping a constant pushing thrust during cutting.



- It is available for Z axis and B2 axis.
- Quill thrust force can be changed in the program.
- It is possible to set OK/ NG range as well.

Dual safety

NT Machine Simulation / NT Collision Guard



Airbag

Dual safety

Double safety features for maximum protection

NT collision Guard to avoid machine collision and Air bag function (Abnormal load detection) to minimize damage even in case of collision.

NT Machine Simulation

Prevent the collision due to tooling, chuck, and program.



Simulation is performed to check the programs without running the machine. This helps prevent machine collisions due to programming or setup errors.

"Distance to go" and "Modal information" can be checked during with simulation.

Rapid feed and Cutting feed can be adjusted using override setting. It is possible to make Simulation of each process, or to use single block.

Process

Single block



Simulation of part machining. There are several view screen display settings, such as machine display, turret display and tooling display.



It is possible to choose between "with" or "without" program display. The color of the program block being simulated can be set to be displayed in a different color.

NT Collision Guard



Preventive safety technology - Machine collisions are avoidable!

This function is available in automatic mode and manual mode. Collisions can be prevented, especially after modifying the program, or changing the tool geometry offset. Registered machine data, chucks, tools, holders, and parts are used to monitor the machine during automatic, manual or jog movement, and recognize in advance collisions before they happen. Even turret indexing is monitored to avoid collisions, drastically reducing machine collision risks, especially during set up.

• Model setup was simplified. Type of tool being indexed is automatically sorted out from the program, and the tool model can be selected from a displayed list.

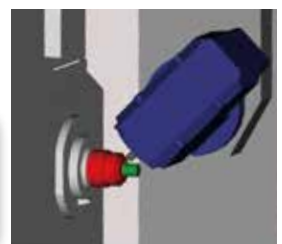
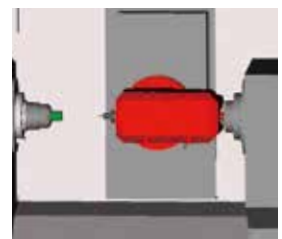



Airbag (Overload detection)

Nakamura-Tome machines will not break for the slightest collision, as other machines do. The function minimize damage in case of collision.

Even with barrier function, machine collisions may occur

Soft barrier function is not perfect.
If wrong data is input, a collision will occur.

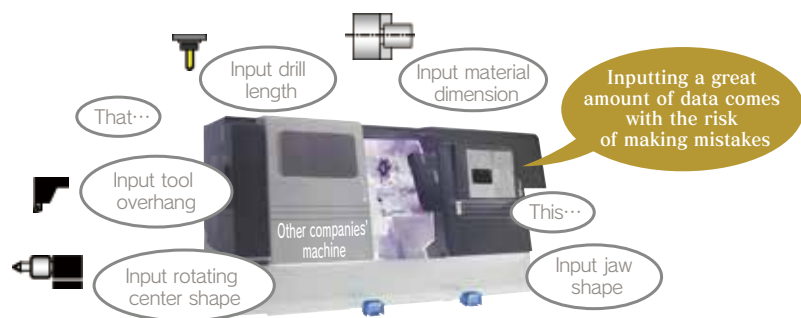

When unavoidable human error results in machine collision, there is no reason to panic.

All Nakamura-Tome machines are equipped with a safety feature called "airbag" (overload detection), which will greatly reduce the impact force and prevent heavy damage to the machine.

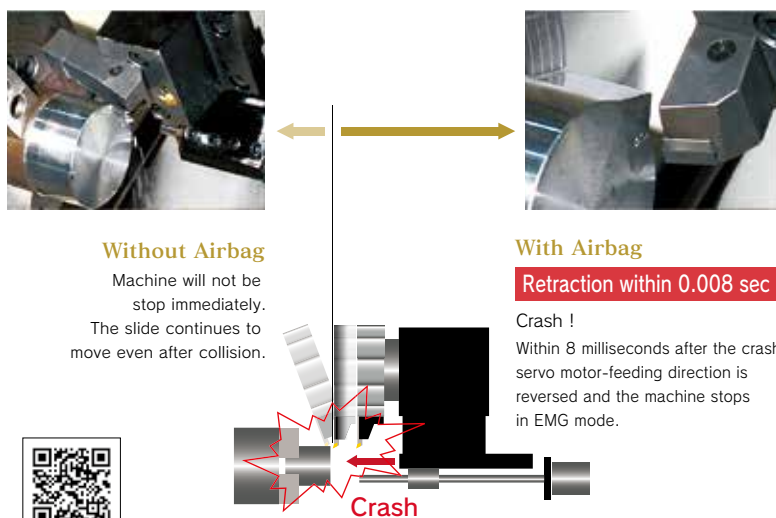

▲ Video

* This feature does not mean zero impact.

NT Work Navigator

New Navigator for X-axis and Y-axis



- **Advanced NT Work Navigator !**
Navigation function is expanded to also include the X and Y-axis. Coordinate Recognition can be made the part's outer surface in the X or Y-Axis direction.
- **No fixtures required**
Machining parts with non-round shapes, such as forgings or castings requires that the raw part coordinates be recognized by the CNC control. In order to achieve this without requiring extra cost or additional options, the NT Navigator is used. It works just by touching the part with a simple inexpensive probe (mostly round bar mounted on a tool holder) and using the torque control feature of the servo-motor, which is to record required coordinates in the CNC. The NT Navigator is a cost cutting feature in multitasking machines, eliminating the need for positioning fixtures and special clamping devices.

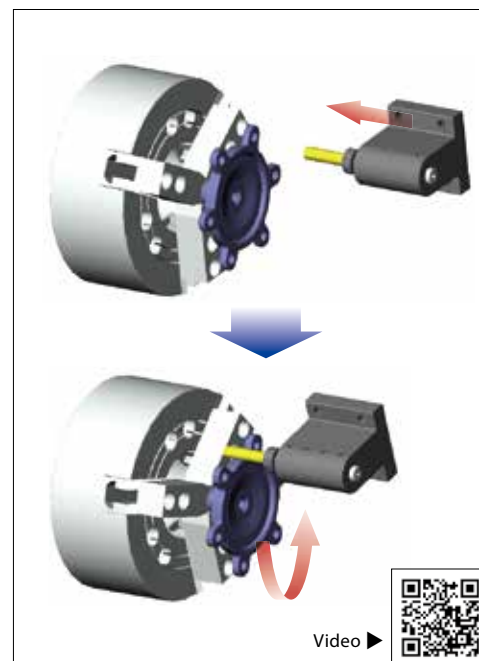

Video ▶



NT Multitasking Office (op.)



By integrating 3D CAD models of the machine, chucks, tools and part, with the dynamics of the real machine (parameter settings) as well as guided programming, Multitasking Office enables virtual planning and verification of the production process.

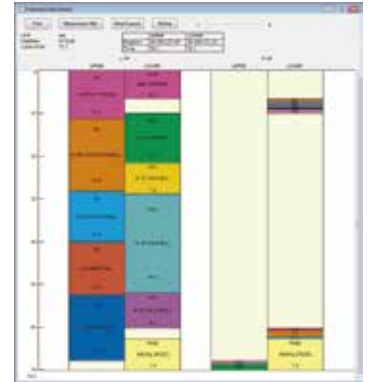

The cutting time of each process is displayed on the graph.



Machining layout sheet is automatically generated.

Efficient Programming for Higher productivity

Shorter set-up times

Drastically reducing set-up time leads to higher productivity

Virtual simulation of the machining processes using 3D solid models of the machine, chucks, tool holders and tools, coupled with all the features of NT-Manual guide I, contribute to not only high efficiency programming and reduced cycle times, but also prevent collisions and reduce set up time.

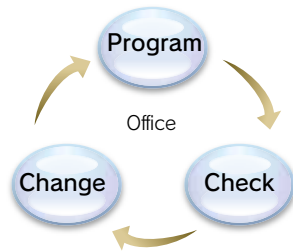

• Features

- 1 Simulation is possible either from Manual guide program (including 4-digit G-codes), or from ISO NC program.
- 2 Simulation of Canned cycles such as G71, G83 and NT-Nurse, NT-Navi, codes.
- 3 Simulation of programs using Jump programming function (G411) is available as well.

NT Multitasking Office merit

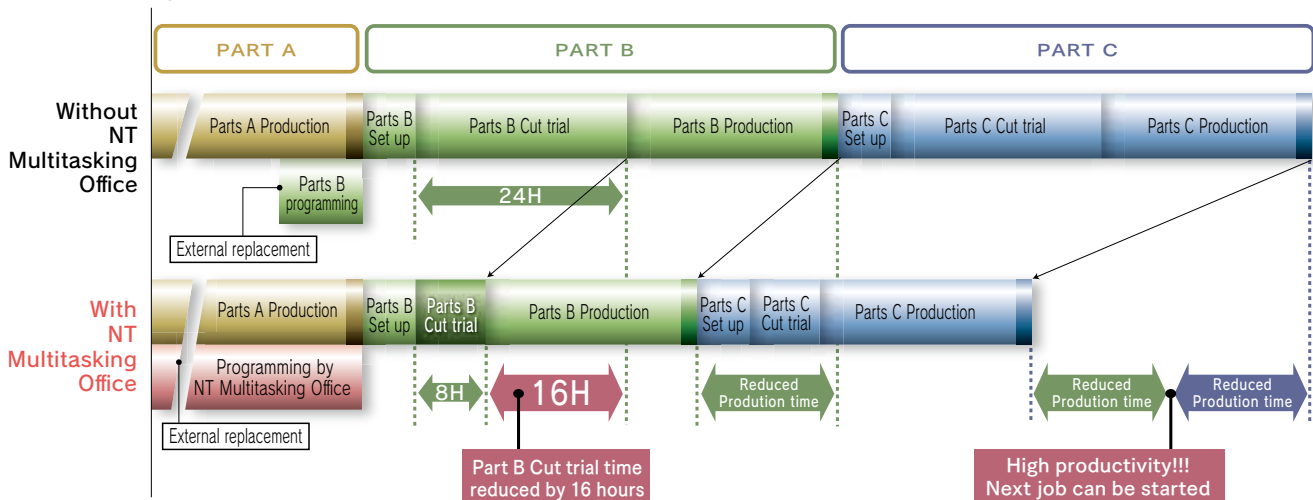

* Windows based PC is required to use "NT Multitasking-Office"



Net Monitor (op.)

• Remote visual monitoring of machine

Net-Monitor provides the capability to gather information and administrate the machines from a PC.



Maximum 80 machines

Machine Status Function

By using Net-MONITOR with the NT-NURSE together, it is possible to have an effective production management of the machine-tool.

Operation Monitoring

View machine running conditions.

Machining Program Management

Program Input / Output is available.

Offset Changing Function

It is available to change the tool offset.

Email Function

Receive Emails from Net Monitor about alarm status. It is also possible to send Emails to mobile telephones as well.

CNC Display Function

It is possible to remotely see the machine CNC Display from a PC.

• Smartphone function



* To use NET Monitor, a PC is required separately.



Combining Turning and Milling Capabilities

L / R spindle motor

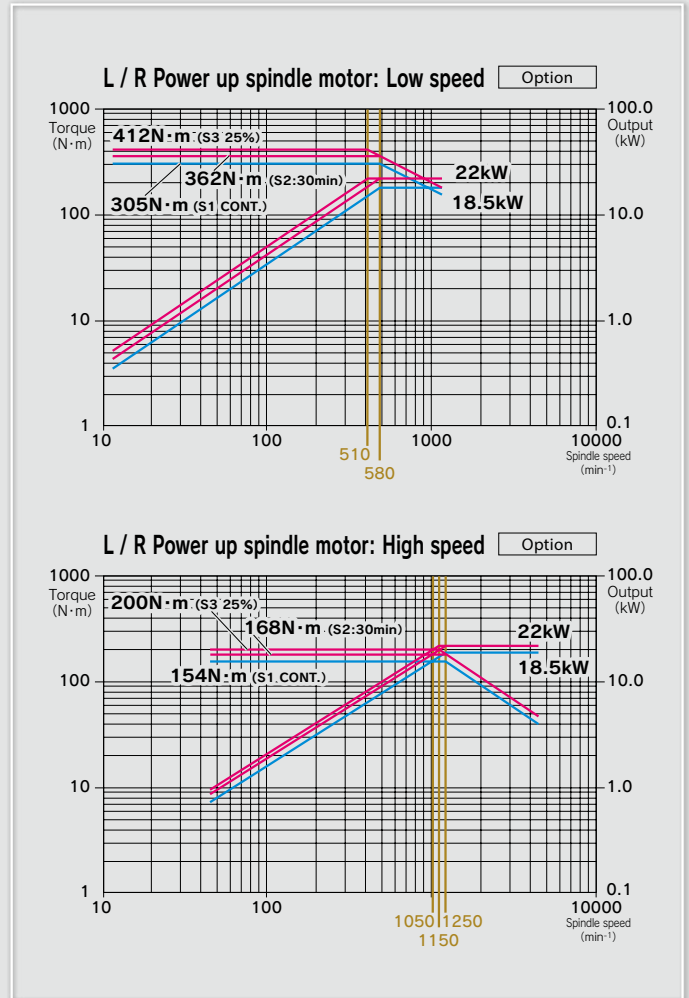
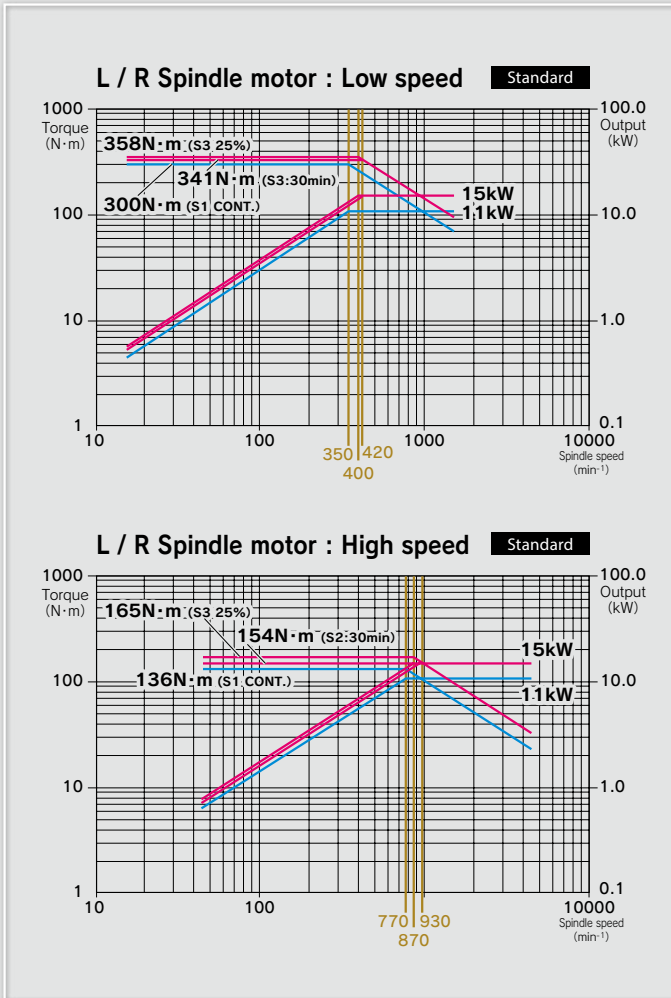

Tool spindle motor

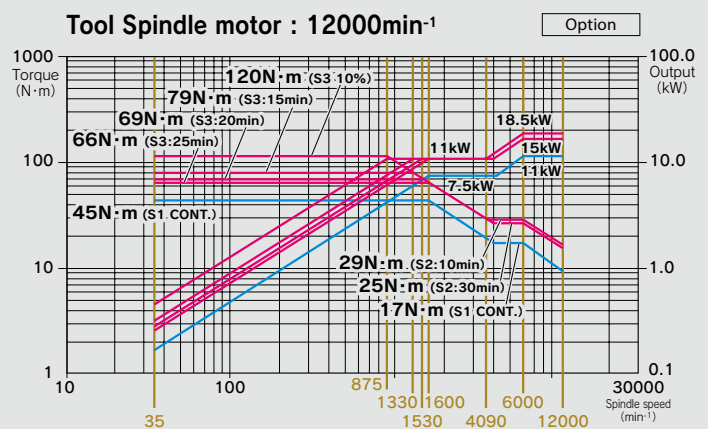
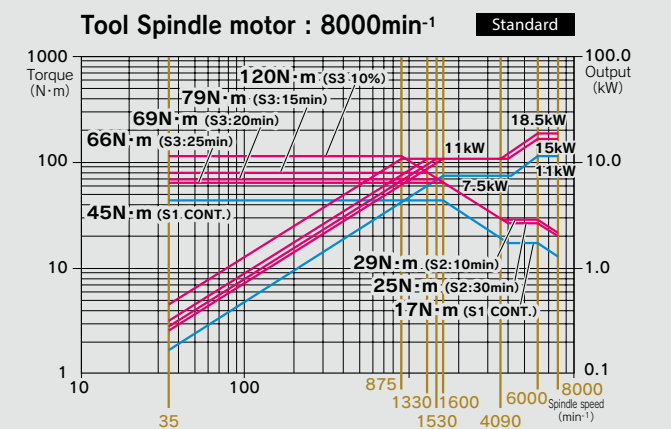



Machine Dimensions

NTRX-300

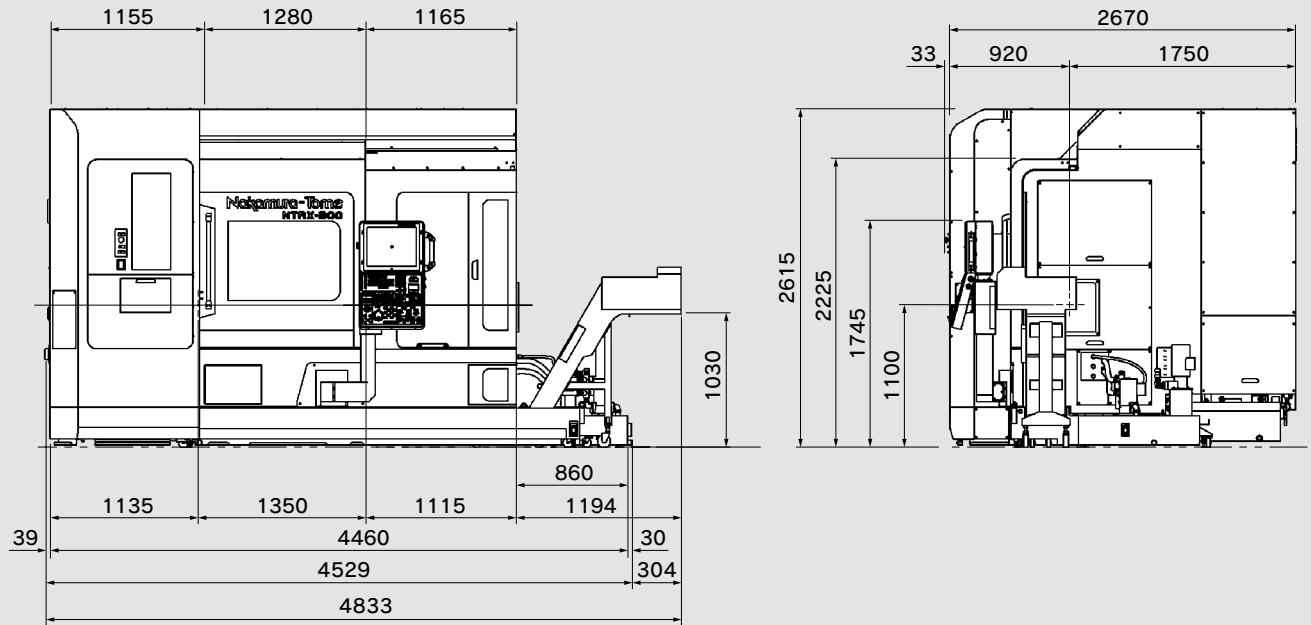

Machine Dimensions

NTRX-300L

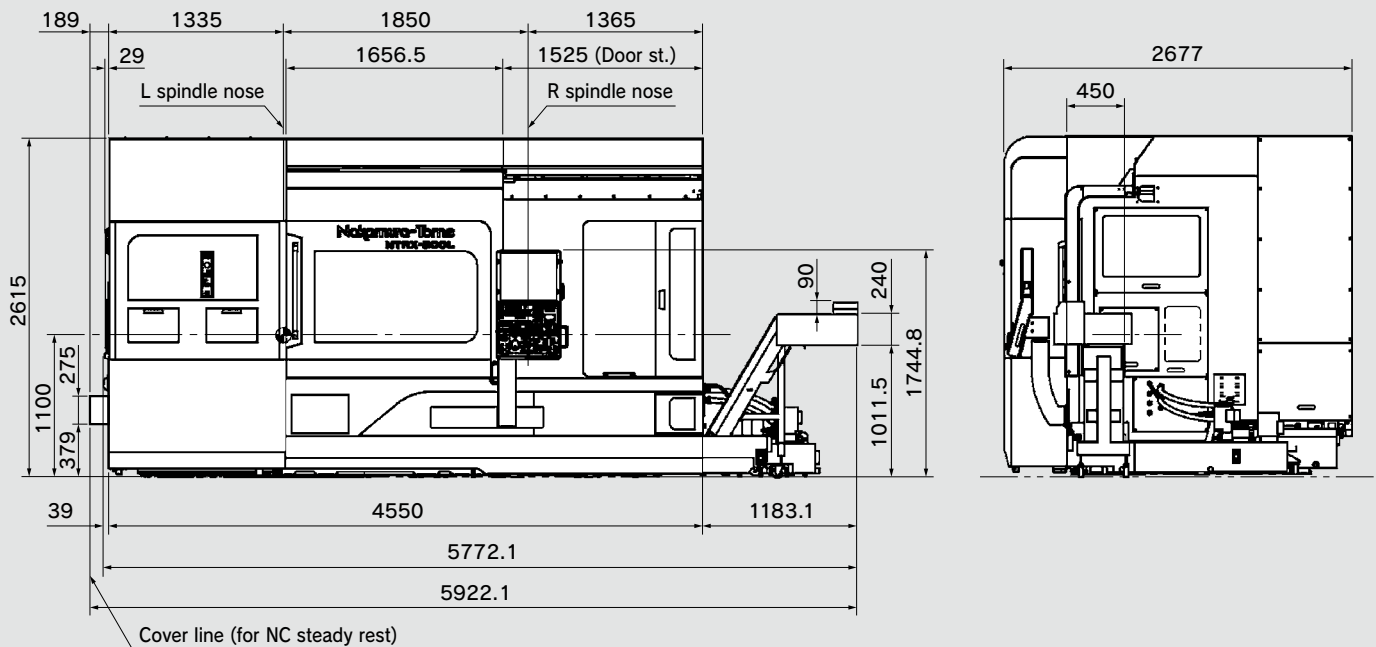



Slide Travel Range

NTRX-300 R Spindle

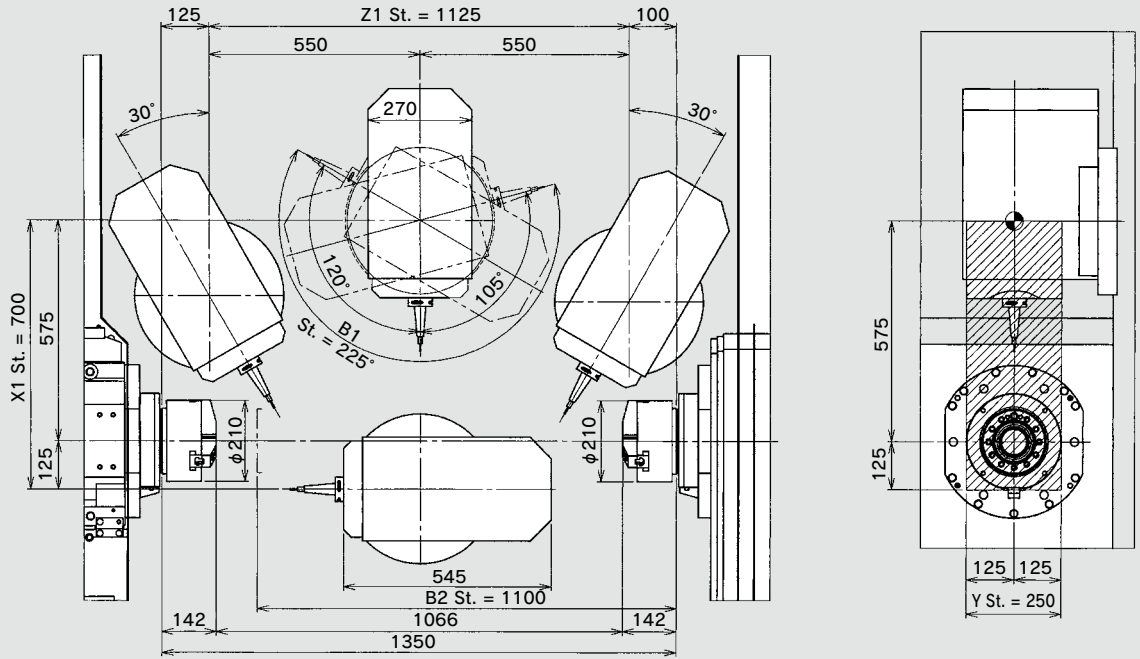

NTRX-300 R Spindle with Short Type Tool Spindle

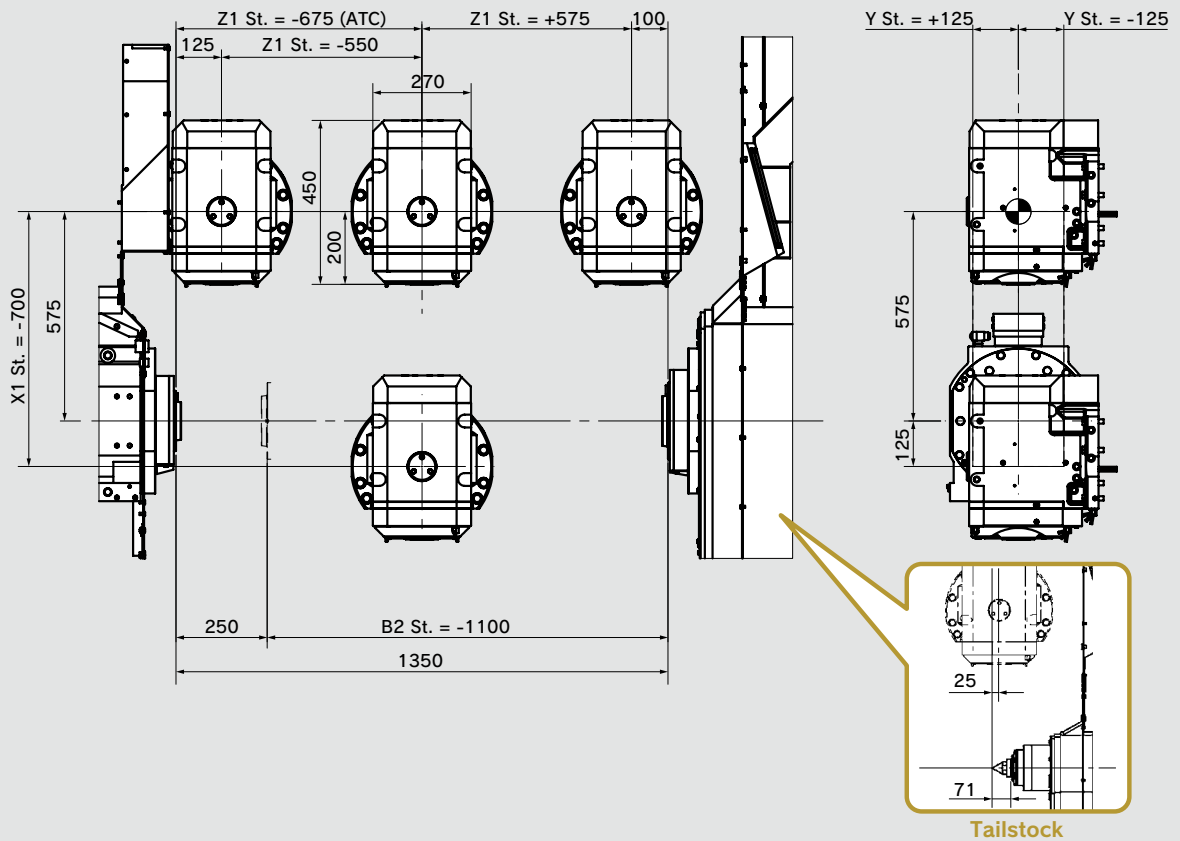

NTRX-300L R Spindle with Steady Rest

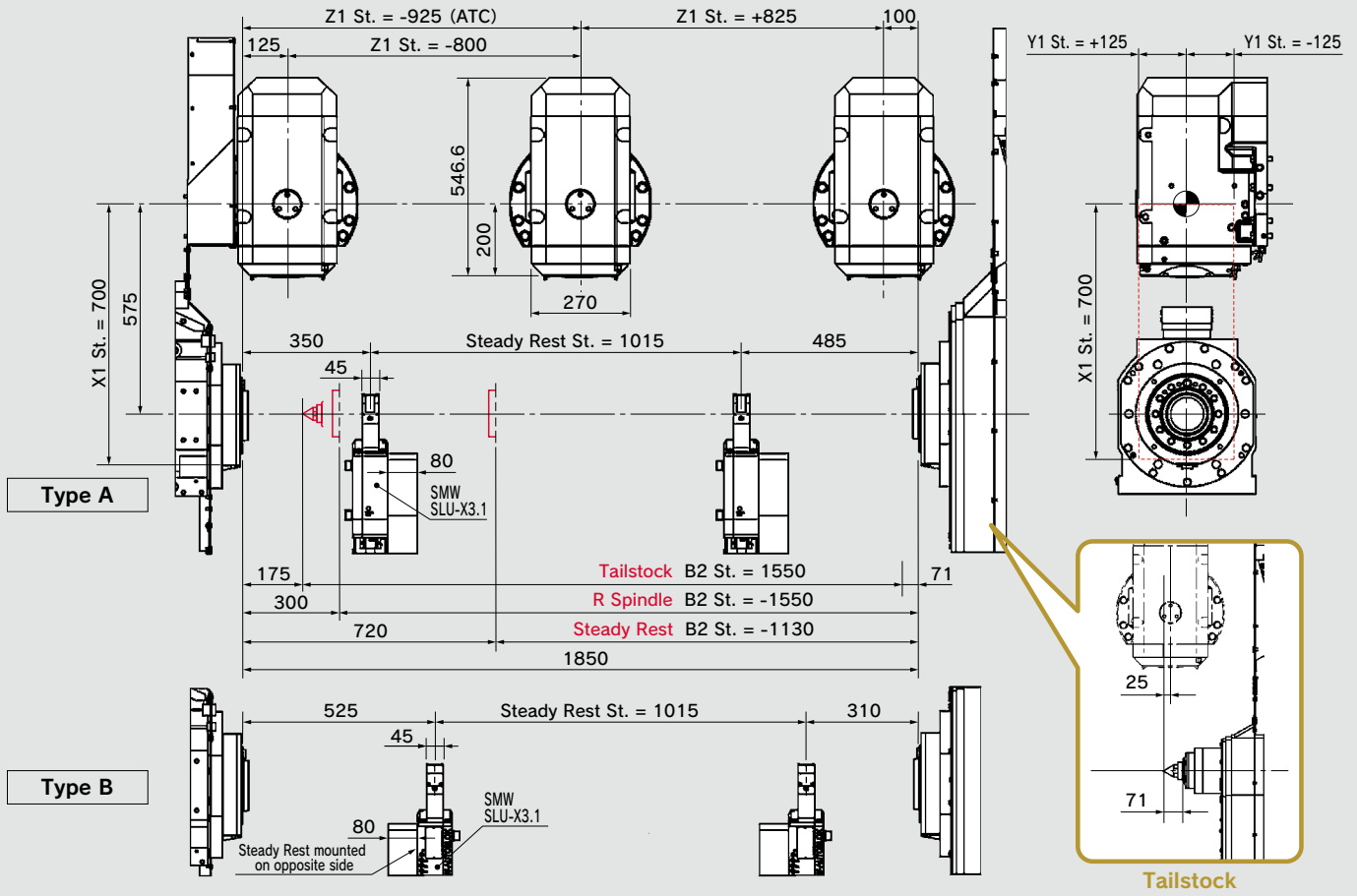

NTRX-300L R Spindle with Short Type Tool Spindle

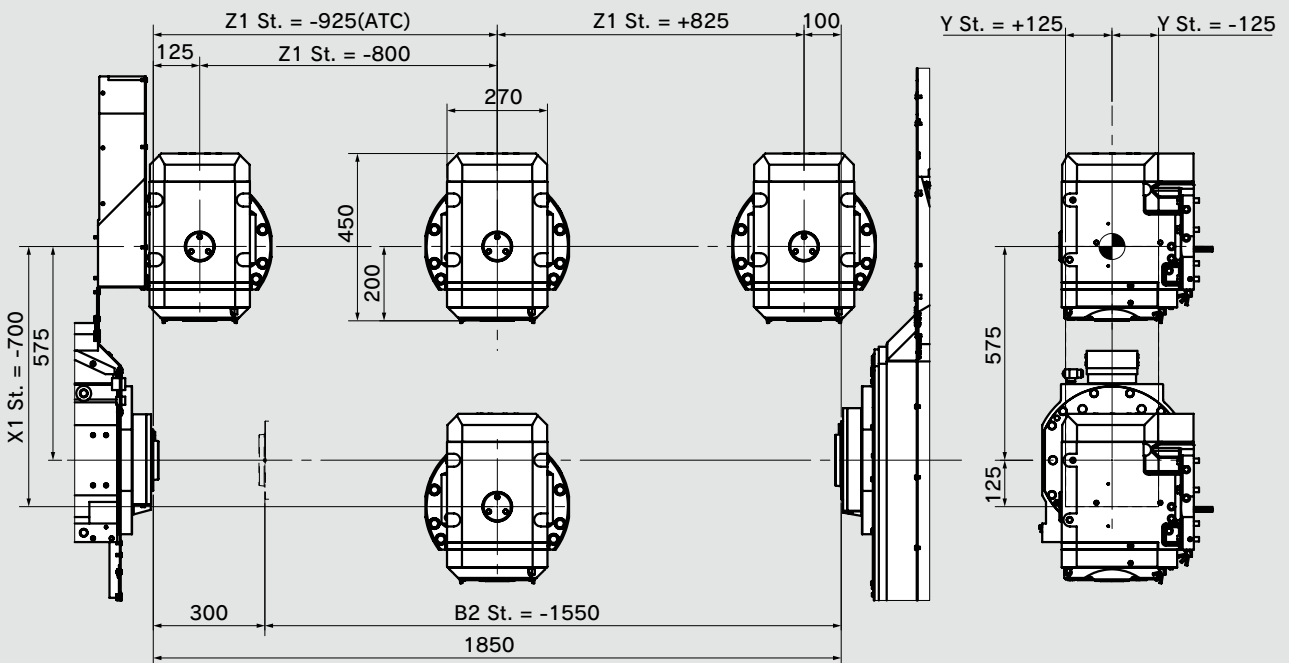



Machine Specifications



Capacity

Max. turning diameter	640mm					
Standard turning diameter	300mm					
Distance between centers	(R Spindle)	max.1,350mm / min.250mm				
	(Tailstock)	max.1,225mm / min.150mm				
Max. turning length	1,100mm					
Bar capacity	L-Spindle	65mm	71mm (op.)	80mm (op.) *1	80mm (op.)	90mm (op.)
	R-Spindle	65mm	71mm (op.)	80mm (op.) *1	80mm (op.)	
Chuck size	210mm (8"), 254mm (10")					

Left spindle

	$\varnothing 65$	$\varnothing 71$ (op.)	$\varnothing 80$ (op.)		$\varnothing 90$ (op.)
Spindle speed	4,500min ⁻¹	3,500min ⁻¹	3,500min ⁻¹	2,500min ⁻¹	2,500min ⁻¹
Spindle speed range	Stepless				
Spindle nose	A2-6	A2-8	A2-8		A2-8
Hole through spindle	80mm	85mm	85mm	107mm	107mm
I.D. of front bearing	120mm	130mm	130mm	150mm	150mm
Hole through draw tube	66mm	72mm	81mm	81mm	91mm
Spindle motor	15/11kW		22/18.5kW (op.)		

Right spindle (option)

	$\varnothing 65$	$\varnothing 71$ (op.)	$\varnothing 80$ (op.)		$\varnothing 90$ (op.)
Spindle speed	4,500min ⁻¹	3,500min ⁻¹	3,500min ⁻¹	2,500min ⁻¹	-
Spindle speed range	Stepless				-
Spindle nose	A2-6	A2-8	A2-8	A2-8	-
Hole through spindle	80mm	85mm	85mm	107mm	-
I.D. of front bearing	120mm	130mm	130mm	150mm	-
Hole through draw tube	66mm	72mm	81mm	81mm	-
Spindle motor	15/11kW		22/18.5kW (op.)		-

Axis travel

Slide travel X1	700mm
Slide travel Z1	1,125mm
Slide travel Y	250mm (±125mm)
Slide travel B2	1,100mm
Rapid feed X1	36m/min
Rapid feed Z1	36m/min
Rapid feed B2	27m/min
Rapid feed Y	36m/min

*1. Direct connection type (Without draw tube adaptor)

Precautions about the use of cutting coolant

Synthetic Coolants are Damaging to Machine Components. Concerning the use of cutting fluids, cautions have to be taken on the type of coolant being used. Among coolants available in the market, some types are damaging to machine components and should be avoided. Typical damages are turcrite wear, peeling of paint, cracking and damage to plastics and polymers, expansion of rubber parts, corrosion and rust build up on aluminum and copper. To prevent such damages, coolants that are synthetic, or containing chlorine have to be avoided. Machine warranty terms do not apply to any claims or damage arising from the use of improper coolant.

C-axis L, R

Least input increment	0.001°
Least command increment	0.001°
Rapid index speed	400min ⁻¹
Cutting feed rate	1 - 4800°/min
C-axis clamp	Disk clamp
C-axis engage time	1.5sec.

Tailstock (option)

Driving Methods	NC control servo driven
Tailstock positioning stroke	1,100mm
Rapid feed rate	8,000mm/min
Tailstock spindle taper size	MT-5 (built in center)
Ball screw diameter / Ball screw pitch	36mm / 10mm
Tailstock force	2.5 - 6.5kN

Tool spindle

Tool spindle speed	45 - 8,000min ⁻¹ (op. 45 - 12,000min ⁻¹)
Tool shank type	HSK-A63 (op. CAPTO C6)
Number of tools	40 (op. 60, 80, 120)
max. tool diameter / without adjacent tool	90mm / 130mm
max. tool length / max.tool weight	300mm / 12kg
ATC time (Tool to tool)	2.5sec. (in case tool weight would be less than 6kg on high speed mode, 1.75sec.)
Tool spindle motor	18.5/11kW

Tool spindle B1-axis

Swiveling range	225° (-120°, +105°)
Indexing mechanism	Servo motor + cam
Clamp function	Curvic coupling (5 degree) Brake (0.001 degree)

General

Machine height	2,615mm
Floor space	4,460mm × 2,670mm (included chiptank) 4,917mm × 2,670mm (included chip conveyor & chiptank)
Machine weight	17,000kg

Power source

Power supply	38.6kVA (L spindle : 15/11kW NC tailstock) 45.1kVA (L spindle : 22/18.5kW NC tailstock) 48.5kVA (L, R Spindle 15/11kW) 61.4kVA (L, R Spindle 22/18.5kW)
Air supply	400NI/min 0.5 - 0.7MPa

Tank capacity

Hydraulic unit	60L
LubricationOil cooler	0.7L

• Safety devices such as various interlocks, fences for robotics, auto loading device, work stocker, automatic fire extinguisher etc. are available as options which can be included in your purchase package. Please contact our local distributor and dealer for your specific requirements.

Control Specifications



■ Items

Control Type	FANUC 31i-B5 1-PATH
--------------	---------------------

■ Controlled axes

Controlled axes	6-axis
Simultaneously controlled axes	5-axis (X1, Z1, C1, Y1, B1, B2)

■ Input command

Least input increment	X, Z, Y, B2 0.001 mm / 0.0001 in (diameter for X-axis) B1, C : 0.001°
Least command increment	X1 : 0.0005mm Z1, Y1, B2 : 0.001mm C1, B1 : 0.001°
Max. programmable dimension dimension	±999999.999mm/±39370.0787in, ±999999.999°
Absolute / incremental programming	X, Z, C, Y, B1, B2 / U, W, H, V (absolute only for B1, B2)
Decimal input	Standard
Inch / Metric conversion	G20 / G21
Programmable data input	G10

■ Feed function

Cutting feed	feed / min X1, Z1, Y1 : 1 - 8000mm/min, 0.01 - 314in/min B1 : 1 - 8000°/min C1 : 1 - 4800°/min B2 : 1 - 4800mm/min, 0.01 - 88in/min feed / rev X1, Z1, Y1 : 0.0001 - 8000.0000mm/rev (0.001 - 4800.0000mm/rev) B2 : 0.0001 - 4800.0000mm/rev, 0.000001 - 50.000000in/rev Note) Max. cutting feed is the value when AI contouring mode. Max. cutting feed except AI contouring mode is :
Dwell	G04
Feed per minute / Feed per revolution	G98 / G99
Thread cutting	G32F
Thread cutting retract	Standard
Continuous thread cutting	Standard
Handle feed	Manual pulse generator 0.001/0.01/0.1mm, ° (per pulse)
Automatic acceleration / deceleration	Standard
Linear acceleration / deceleration after cutting feed interpolation	Standard
Rapid feed override	LOW / 25 / 50 / 100% (changeable to every 10% by switch)
Cutting feed-rate override	0 - 150% (each 10%)
AI contouring control I	G5.1
L spindle override	50 - 120% changeable to every 10%
Tool spindle override	50 - 120% changeable to every 10%

■ Tool nose R compensation

Tool nose R compensation	G41, G42 / G40
Number of tool offset pairs	99 (ATC40)
	Tail stock type 99 (ATC60, ATC80), 200 (ATC120)
	Sub spindle type 200 (ATC60, ATC80), 400 (ATC120)
Direct input of measured offset value	Standard (Available to set for using the position record on the tool setting screen.)
Y-axis offset	Standard

■ Program memory

Part program storage length	512kbyte (Total 1280m)
Part program edit	delete, insert, change
Program number search	Standard
Sequence number search	Standard
Address search	Standard
Number of registrable programs	Total 1000pcs
Program storage memory	backed up by battery
Multiple program simultaneous editing	Standard
DNC operation through memory card	Standard (not including memory card)
Extended part program editing	Standard (Replacement of word, address, cut & paste for word / character, cancel operation, copy or move the program)

■ Operation and display

HMI (Human Machine Interface)	NT Smart X
Operation panel : Display	19" color SXGA LCD touch panel
Operation panel : Keyboard	QWERTY keyboard
O/S	Windows 8.1 (There are some restrictions depending on application to be installed)
Pointing device	Touch pad

■ Program support

Circular interpolation R programming	Standard
Direct drawing dimension programming or Chamfering / Corner R	Standard (Direct drawing dimension programming is standard)
Canned cycle	G90, G92, G94
Multiple repetitive canned cycle	G70 - G76
Multiple repetitive canned cycle II	G71, G72
Canned cycle for drilling	G80 - G89
Sub program	Standard
Help function	Standard
Custom macro	Standard (common variable#100 - #149, #500 - #549)
Addition to custom macro common variables	Standard (After addition, #100 - #199, #500 - #999)
3-D coordinate convert	Standard
3-D rigid tap	Standard
Helical interpolation	Standard
NT Manual Guide i	Standard
Abnormal Load detection	Standard
NT Work Navigator	Standard (not including contact bar)
NT NURSE	Standard

■ Mechanical support

Rigid tap	Standard
Spindle orientation	Standard
Tool spindle orientation	Standard : 4 positions (90°× 4/ M785/ M786/ M787/ M788) Maximum : 12 positions (30°× 12/ G419)



Machine Specifications

Capacity

Max. turning diameter	640mm					
Standard turning diameter	300mm					
Distance between centers	(R Spindle)	max.1,850mm / min.350mm				
	(Tailstock)	max.1,796mm / min.246mm				
	(Steady rest)	max.1,850mm / min.720mm				
	(Tailstock, Steady rest)	max.1,796mm / min.666mm				
Max. turning length	1,600mm					
Bar capacity	L-Spindle	65mm	71mm (op.)	80mm (op.) *1	80mm (op.)	90mm (op.)
	R-Spindle	65mm	71mm (op.)	80mm (op.) *1	80mm (op.)	-
Chuck size	210mm (8"), 254mm (10")					

Left spindle	$\phi 65$	$\phi 71$ (op.)	$\phi 80$ (op.)		$\phi 90$ (op.)
Spindle speed	4,500min ⁻¹	3,500min ⁻¹	3,500min ⁻¹	2,500min ⁻¹	2,500min ⁻¹
Spindle speed range	Stepless				
Spindle nose	A2-6	A2-8	A2-8		A2-8
Hole through spindle	80mm	85mm	85mm	107mm	107mm
I.D. of front bearing	120mm	130mm	130mm	150mm	150mm
Hole through draw tube	66mm	72mm	81mm	81mm	91mm
Spindle motor	15/11kW		22/18.5kW (op.)		

Right spindle (option)	$\phi 65$	$\phi 71$ (op.)	$\phi 80$ (op.)		$\phi 90$ (op.)
Spindle speed	4,500min ⁻¹	3,500min ⁻¹	3,500min ⁻¹	2,500min ⁻¹	-
Spindle speed range	Stepless				
Spindle nose	A2-6	A2-8	A2-8	A2-8	-
Hole through spindle	80mm	85mm	85mm	107mm	-
I.D. of front bearing	120mm	130mm	130mm	150mm	-
Hole through draw tube	66mm	72mm	81mm	81mm	-
Spindle motor	15/11kW		22/18.5kW (op.)		

Axis travel

Slide travel X1	700mm
Slide travel Z1	1,625mm
Slide travel Y	250mm (±125mm)
Slide travel B2	1,550mm 1,015mm (Steady rest)
Rapid feed X1	36m/min
Rapid feed Z1	36m/min
Rapid feed B2	27m/min
Rapid feed Y	36m/min

*1. Direct connection type (Without draw tube adaptor)

Precautions about the use of cutting coolant

Synthetic Coolants are Damaging to Machine Components. Concerning the use of cutting fluids, cautions have to be taken on the type of coolant being used. Among coolants available in the market, some types are damaging to machine components and should be avoided. Typical damages are turcite wear, peeling of paint, cracking and damage to plastics and polymers, expansion of rubber parts, corrosion and rust build up on aluminum and copper. To prevent such damages, coolants that are synthetic, or containing chlorine have to be avoided. Machine warranty terms do not apply to any claims or damage arising from the use of improper coolant.

C-axis L, R

Least input increment	0.001°
Least command increment	0.001°
Rapid index speed	400min ⁻¹
Cutting feed rate	1 - 4800°/min
C-axis clamp	Disk clamp
C-axis engage time	1.5sec.

Tailstock (option)

Driving Methods	NC control servo driven
Tailstock positioning stroke	1,550mm
Rapid feed rate	8,000mm/min
Tailstock spindle taper size	MT-5 (built in center)
Ball screw diameter / Ball screw pitch	36mm / 10mm
Tailstock force	2.5 - 6.5kN

Tool spindle

Tool spindle speed	45 - 8,000min ⁻¹ (op. 45 - 12,000min ⁻¹)
Tool shank type	HSK-A63 (op. CAPTO C6)
Number of tools	40 (op. 60, 80, 120)
max. tool diameter / without adjacent tool	90mm / 130mm
max. tool length / max.tool weight	300mm / 12kg
ATC time (Tool to tool)	2.5sec.
Tool spindle motor	18.5/11kW

Tool spindle B1-axis

Swiveling range	240° (±120)
Indexing mechanism	Servo motor + cam
Clamp function	Curvic coupling (5 degree) Brake (0.001 degree)

General

Machine height	2,615mm
Floor space	5,440mm × 2,677mm (included chiptank) 5,744mm × 2,677mm (included chip conveyor & chiptank)
Machine weight	19,000kg / ATC40

Power source

Power supply	39.2kVA (L spindle : 15/11kW NC tailstock) 45.8kVA (L spindle : 22/18.5kW NC tailstock) 48.8kVA (L, R Spindle 15/11kW) 62.0kVA (L, R Spindle 22/18.5kW)
Air supply	400NL/min 0.5 - 0.7MPa

Tank capacity

Hydraulic unit	60L
LubricationOil cooler	0.7L

• Safety devices such as various interlocks, fences for robotics, auto loading device, work stocker, automatic fire extinguisher etc. are available as options which can be included in your purchase package. Please contact our local distributor and dealer for your specific requirements.

Control Specifications



■ Items

Control Type	FANUC 31i-B5 1-PATH
--------------	---------------------

■ Controlled axes

Controlled axes	6-axis
Simultaneously controlled axes	5-axis (X1, Z1, C1, Y1, B1,B2)

■ Input command

Least input increment	X1, Z1, Y1, B2 : 0.001mm / 0.0001in (diameter for X-axis) B1, C1 : 0.001°
Least command increment	X1 : 0.0005mm Z1, Y1, B2 : 0.001mm C1, B1 : 0.001°
Max. programmable dimension dimension	±999999.999mm/±39370.0787in, ±999999.999°
Absolute / incremental programming	X, Z, C, Y, B1, B2 / U, W, H, V (absolute only for B1, B2)
Decimal input	Standard
Inch / Metric conversion	G20 / G21
Programmable data input	G10

■ Feed function

Cutting feed	<p>eed / min X1, Z1, Y1 : 1 - 8000mm/min, 0.01 - 314in/min B1 : 1 - 8000°/min C1 : 1 - 4800°/min B2 : 1 - 4800mm/min, 0.01 - 188in/min</p> <p>feed / rev X1, Z1, Y1 : 0.0001 - 8000.0000mm/rev B2 : 0.0001 - 4800.0000mm/rev, 0.000001 - 50.000000in/rev</p> <p>Note) Max. cutting feed is the value when AI contouring mode. Max. cutting feed except AI contouring mode is :</p> <p>eed / min X1, Z1, Y1 : 1 - 4800mm/min, 0.01 - 188in/min B1 : 1 - 4800°/min</p> <p>feed / rev X1, Z1, Y1 : 0.0001 - 4800.0000mm/rev</p>
Dwell	G04
Feed per minute / Feed per revolution	G98 / G99
Thread cutting	G32F
Thread cutting retract	Standard
Continuous thread cutting	Standard
Handle feed	Manual pulse generator 0.001/0.01/0.1mm, ° (per pulse)
Automatic acceleration / deceleration	Standard
Linear acceleration / deceleration after cutting feed interpolation	Standard
Rapid feed override	LOW / 25 / 50 / 100% (changeable to every 10% by switch)
Cutting feed-rate override	0 - 150% (each 10%)
AI contouring control I	G5.1
L spindle override	50 - 120% changeable to every 10%
Tool spindle override	50 - 120% changeable to every 10%

■ Tool nose R compensation

Tool nose R compensation	G41, G42 / G40
Number of tool offset pairs	99 (ATC40)
	Tail stock type 99 (ATC60, ATC80), 200 (ATC120)
	Sub spindle type 200 (ATC60, ATC80), 400 (ATC120)
Direct input of measured offset value	Standard (Available to set for using the position record on the tool setting screen.)
Y-axis offset	Standard

■ Program memory

Part program storage length	512kbyte (Total 1280m)
Part program edit	delete, insert, change
Program number search	Standard
Sequence number search	Standard
Address search	Standard
Number of registrable programs	Total 1000pcs
Program storage memory	backed up by battery
Multiple program simultaneous editing	Standard
DNC operation through memory card	Standard (not including memory card)
Extended part program editing	Standard (Replacement of word, address, cut & paste for word / character, cancel operation, copy or move the program)

■ Operation and display

HMI (Human Machine Interface)	NT Smart X
Operation panel : Display	19" color SXGA LCD touch panel
Operation panel : Keyboard	QWERTY keyboard
O/S	Windows 8.1 (There are some restrictions depending on application to be installed)
Pointing device	Touch pad

■ Program support

Circular interpolation R programming	Standard
Direct drawing dimension programming or Chamfering / Corner R	Standard (Direct drawing dimension programming is standard)
Canned cycle	G90, G92, G94
Multiple repetitive canned cycle	G70 - G76
Multiple repetitive canned cycle II	G71, G72
Canned cycle for drilling	G80 - G89
Sub program	Standard
Help function	Standard
Custom macro	Standard (common variable#100 - #149, #500 - #549)
Addition to custom macro common variables	Standard (After addition, #100 - #199, #500 - #999)
3-D coordinate convert	Standard
3-D rigid tap	Standard
Helical interpolation	Standard
NT Manual Guide i	Standard
Abnormal Load detection	Standard
NT Work Navigator	Standard (not including contact bar)
NT NURSE	Standard

■ Mechanical support

Rigid tap	Standard
Spindle orientation	Standard
Tool spindle orientation	Standard : 4 positions (90°× 4/ M785/ M786/ M787/ M788) Maximum : 12 positions (30°× 12/ G419)



NAKAMURA-TOME PRECISION INDUSTRY CO., LTD

<http://www.nakamura-tome.co.jp>

Netsuno 15, Hakusan city, Ishikawa, 920-2195 Japan

Phone : +81 76 273 8100 Fax : +81 76 273 4312

E-mail : nt-jpn@nakamura-tome.co.jp

- This catalog was published in June, 2017. Specifications, illustrations and data given herein are subject to change without notice.
- The products in this catalog are controlled based on Japan's "Foreign Exchange and Foreign Trade Law". The export of the products are subject to an export license by the Japanese government.