

HD 2600/3100 Series

HD2600/M | HD3100A/MA | HD3100/M/L/LM

HYUNDAI WIA Heavy Duty Cutting CNC Turning Center

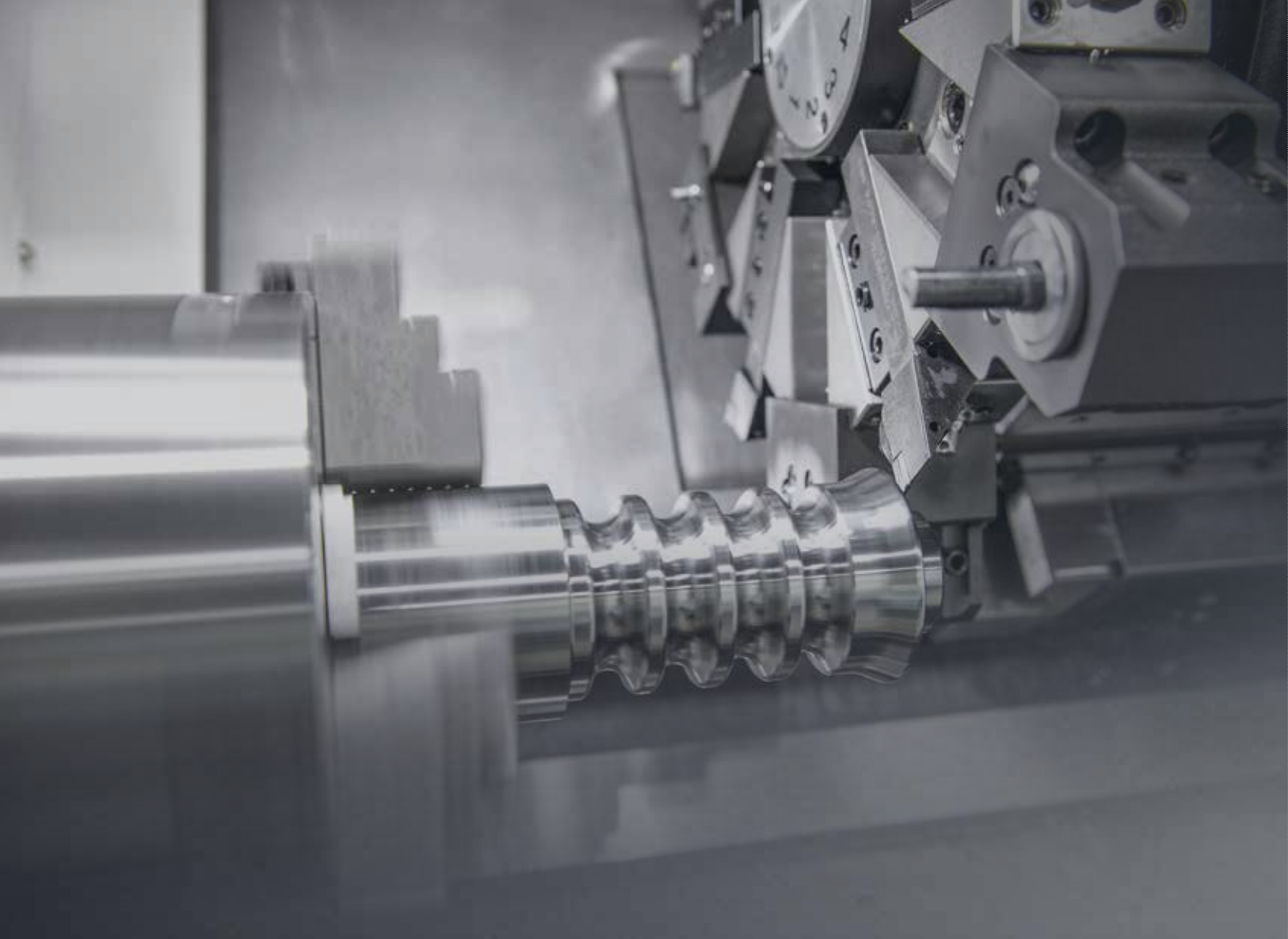

Technical Leader

The CNC Turning Center HD2600/3100 Series, designed by Hyundai WIA with years of expertise and the latest technology, is a Turning Center that maximizes productivity and performance.

ITEM	Chuck		Bed (Z-Axis)			Standard Turret		Mill Turret	
	10"	12"	680mm	830mm	1,350mm	10 Station	12 Station	BMT55P	BMT65P
HD2600	●	○	●			●	○		
HD2600M	●		●					●	
HD3100A	●			●		●	○		
HD3100MA	●			●					●
HD3100		●		●		●	○		
HD3100M		●		●					●
HD3100L		●			●	●	○		
HD3100LM		●			●				●

●: Standard ○: Option

HD

2600/3100 Series

Lathe with Box Guideways for Heavy Cutting

- Box guideways for heavy-duty cutting
- Stabilized unit structure to minimize thermal displacement
- User convenient structure for high productivity
- Excellent rapid traverse rate: 30m/min [1,181ipm] (Z-axis)
- High-rigidity and high-speed servo turret (Expanded disk width)
- Ergonomic design for convenient access to chuck and tool



01 BASIC STRUCTURE

High Productivity 10/12inch CNC Turning Center for Heavy Duty Cutting

Turret

- 10 [Opt. 12] EA
- O.D./I.D. : $\square 25/\varnothing 50$
- HD2600M : BMT55
- HD3100MA | HD3100M/LM : BMT65

Tail Stock

- MT#5
- Quill Dia. : $\varnothing 100$ (3.9")
- Quill Travel : 120 mm (4.7")

High Precision Spindle

- Integral body & heat dissipating RIB structure.
- HD2600/3100A Series : 10"
- HD3100 Series : 12"
- C-Axis Control : 0.001° ('M' Type)

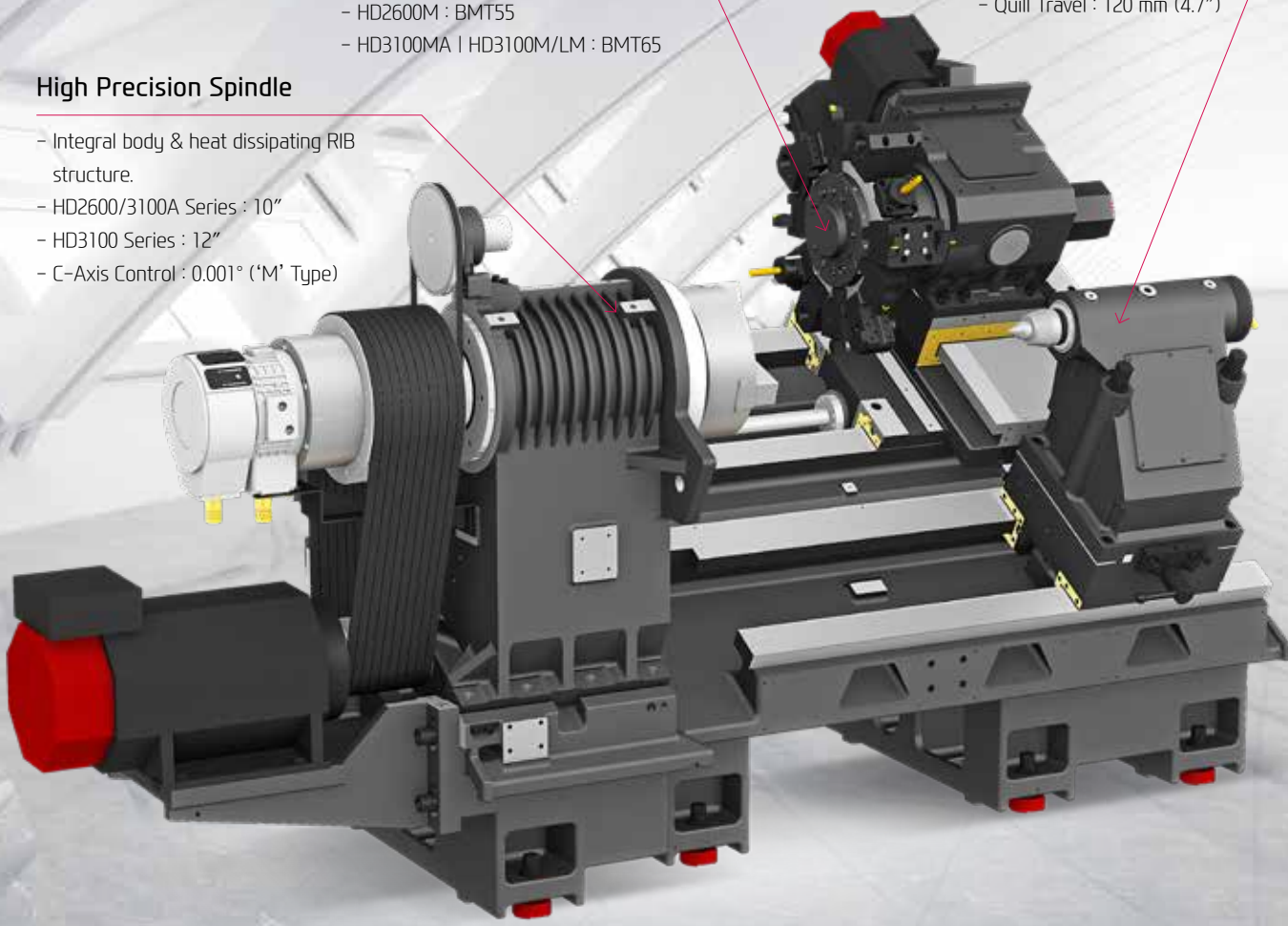

POWERFUL CUTTING CAPABILITY & WIDE CUTTING AREA

ALL-IN-ONE TYPE OF BED

Optimal Structural Analysis

Structural analysis was applied to the design of the machine to increase the tool post body and reduce the machine's height so as to maintain the bed's dynamic rigidity even during heavy-duty cutting.

In addition, the HD2600/3100's bed slope is pitched at 30° to ensure more stable machining.



Integrated Coolant Tank

The structure is designed with the coolant tank installed at the bed front for improved convenience. Chips can be removed from the right side of the machine.

GUIDEWAY

Box Guideway on All Axis

With the mounting of box guideways on all axis, the machine offers excellent vibration absorption even against during heavy-duty cutting, enabling high-quality machining.

Closed-type GIB Structure

The guide attachment surface of X-axis guideway has been changed to a sealed GIB structure to minimize X-axis turcite damage caused by chips. As a result, the machining capacity has been greatly enhanced too.

Rapid Traverse Rate (X/Z axis) : 24/30 m/min (945/1,181 ipm)



6-Face constraint design for improved travel capacity

Travel (X/Z)

HD2600/M	HD3100A/MA HD3100/M	HD3100L/LM
265/680 mm (10.4"/26.8")	265/830 mm (10.4"/32.7")	265/1,350 mm (10.4"/53.1")

02 HIGH PRECISION SPINDLE

Long Lasting, High Accuracy & Excellent Performance CNC Turning Center



Spindle Specifications

[] : Option

Model	Speed r/min	Motor (Max./Cont.)	Max. Torque
HD2600	FANUC 3,500 [2,800 rpm]	26/18.5 kW (35/25 HP)	734 [1,123] N·m (541.4 [828.7] lbf.ft)
HD2600M	FANUC 3,500 rpm	26/18.5 kW (35/25 HP)	734 N·m (541.4 lbf.ft)
	[SIEMENS 3,000 rpm]	[53.2/28 kW (71.3/37.5 HP)]	[1,015.6 N·m 749.1 lbf.ft]
HD3100A/MA	FANUC 3,500 rpm	26/18.5 kW (35/25 HP)	734 N·m (541.4 lbf.ft)
HD3100/L	FANUC 2,800 rpm	26/18.5 [35/32] kW (35/25 [47/29.5] HP)	1,123 [1,613] N·m (828.7 [1,189.7] lbf.ft)
HD3100M/LM	FANUC 2,800 rpm	26/18.5 kW (35/25 HP)	1,123 N·m (828.7 lbf.ft)

HEAVY DUTY CUTTING & HIGH ACCURACY

SPINDLE

Spindle Ideal for Heavy Cutting

The HD2600 and HD3100 feature torque of 734N·m and 1,123N·m, respectively, ensuring excellent performance in heavy-duty cutting, interrupted cutting, and so on. (specially designed for extra heavy workpiece)

In particular, the HD3100 features a gear spindle as an option [gear : 1,613N·m torque], thus meeting customer needs for a stronger heavy-duty cutting function.

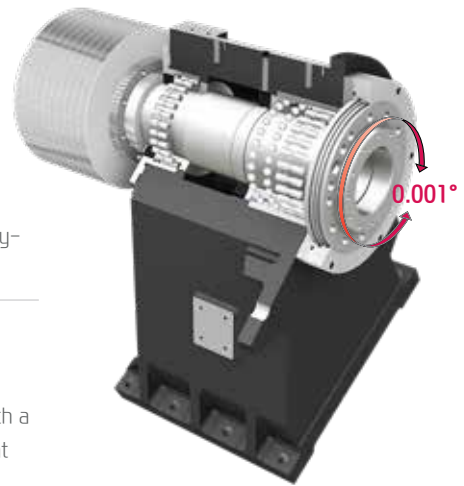

Ribstar Belt

Also, machining performance is enhanced by applying ribstar belt to minimize noise and belt slipping problems. The spindle is designed with a labyrinth structure to minimize possible bearing damage from coolant and to improve machining stability.

C-Axis Control ('M' Type)

C-axis of HD2600M/3100M Series can be controlled to 0.001° which makes it possible to process various shapes.

TAIL STOCK

MT#5 Tail Stock

The HD2600 and HD3100 are fitted with tailstocks as a standard for excellent machining quality. In addition, the travel distance of quill can be as long as 120mm (4.7"), thus expanding the support area.

- ◎ Quill Dia. : $\varnothing 100$ mm (3.9")
- ◎ Quill Travel : 120 mm (4.7")
- ◎ Reinforced Tailstock Rigidity : Thrust 742 kgf → 989 kgf



03 SERVO TURRET

High speed, High Accuracy, Highly Reliable Servo Turret

Servo Turret

[] : Option

No. of Tools

10 [12]_{EA}

Tool Size (O.D./I.D)

□ 25/Ø50 mm (□ 1"/Ø2")

Indexing Time

0.15_{sec}

* HD2600M : □ 25/Ø40 mm (□ 1"/Ø1 1/2")

Mill Turret

[] : Option

Model	Type	Speed	Motor (Max./Cont)	Torque (Max./Cont)
HD2600M	BMT55	FANUC 6,000 rpm	5.5/3.7 kW (7.4/5 HP)	52.5/26.5 N·m (38.7/19.5 lbf.ft)
		[SIEMENS 6,000 rpm]	[4.2/2.8 kW (5.6/3.8 HP)]	[40.1/26.7 N·m (29.6/19.7 lbf.ft)]
HD3100MA HD3100M/LM	BMT65	FANUC 5,000 rpm	5.5/3.7 kW (7.4/5 HP)	70/35.4 N·m (51.6/26.1 lbf.ft)
		[FANUC 5,000 rpm]	[7.5/3.7 kW (10/5 HP)]	95.5/35.4 N·m (70.4/26.1 lbf.ft)

VARIOUS DRIVEN PRECISION VDI TOOL HOLDERS

TURRET

Servo Turret

The turret of HD2600/3100 series is joined with a high performance AC servo motor, improving machining reliability.

The 3-piece coupling shows excellent performance in indexing. Powerful hydraulic tool clamping minimizes tool tip deviation caused by workload.

High Pressure Coolant **OPTION**

Turret is designed to utilize 20 bar (290 psi) high pressure coolant and it shows optimum performance in machining difficult-to-cut material.

⊙ Static-Rigidity Increased : I.D 20%, O.D 3% ↑

HD2600

90 mm (3.5") 20% UP

HD3100/A

120 mm (4.7") 20% UP



BMT Turret

BMT turret where each holder is fixed with 4 screws, shows outstanding performance in milling, drilling and tapping during heavy-duty cutting.

STRAIGHT MILLING HEAD



ANGULAR MILLING HEAD



Mill Tool Holder

Machining capability has increased with the addition of straight milling head tool holder, which can machine workpieces from the side, and angular milling head tool holder, which can perform I.D. operations.



Special Tool

OPTION

The HD2600/3100 series can process high value-added products using a variety of rotating tools. In particular, there is a multi-holder for attaching a variety of tools to one holder, and an eccentric rotary tool for handling eccentric parts without additional axis travel, which can realize integration of process with one machine.

❖ Consultation needed when ordering these options.

04 USER CONVENIENCE

Various Devices for User Friendly

BAR FEEDER SYSTEM



Bar Feeder

Bar feeder system enables automation which leads to efficiency improvement.



Parts Catcher

An optional parts catcher collects finished parts without the need to open the door, adding productivity, especially when a bar feeder is attached.



Auto Door

Using M-code, the doors can be automatically opened and closed which brings productivity and convenience for automation.



Parts Conveyor

The parts conveyor transfers the finished workpiece unloaded by the parts catcher for user convenience.



Auto Shutter

Using auto shutter, automation system with gantry loader is possible without opening the machine's door.

GANTRY LOADER SYSTEM

Gantry Loader Machining Process

The high speed gantry loaders and the work stocker allow the implementation of automation cells. This enables flexible machining process and productivity enhancement. Optimization of the installation space is also possible.



Raw Material

1st Machining

Turn Over

2nd Machining

End Product

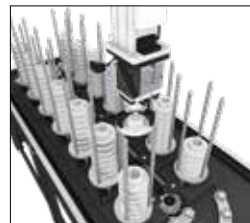
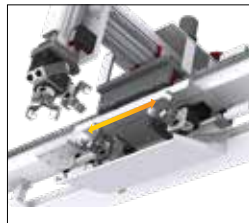

Unloading & Loading

Unloading & Loading

Optional

CHIP DISPOSAL SOLUTION

Timely and effective disposal of chips will enhance productivity as well as the working environment.



Hinge	Chip Type : Roughing Chip, Long Chip, Chip complex	Material : SS41, 45C, Cast Steel	Front-Right Direction
	Highly efficient when disposing a lot of chips. Capable of handling stringy chips..		
Scraper	Chip Type : Finely broken chip blown out	Material : cast Iron, Nonferrous	
	Convenient for shortly cut chips.		
❖ Drum Filter	Chip Type : Powder, Micro Chip	Material : AL	
	Advantageous in precision, as the chips do not flow in to the coolant nozzle.		

❖ When ordering a drum filter chip conveyor, prior consult with hyundai wia's sales person.

HIGH PRECISION SYSTEM & COOLANT UNIT



Automatic Q-Setter



Linear Scale



Work Probe



Standard Coolant (Nozzle)



Chuck Coolant (Upper Chuck)



Chuck Air Blow (Upper Chuck)

05 HYUNDAI WIA FANUC – SMART PLUS

The Compatible All-round Control



15" Touch-type Monitor as a standard



Fast Cycle Time Technology	Smart Machine Control	Fine Surface Technology
Smart Servo Control Technology	Conversational Program	SmartGuide-i
Machining-aid Function	i-HMI	5120M (2MB)
No. of Registerable Programs 1000 EA	Part Program Storage	

Servo Learning Oscillation Function for Chip Breaking **OPTION**

- Machining Method : he tool cuts the workpiece moving in a zigzag pattern. (Oscillating) → Air cut section occurs → Long chips break
- Advantage : Increase tool life, Enhance surface finishing, Improve chip disposal
- Machine : All turning centers with FANUC controller (Option)

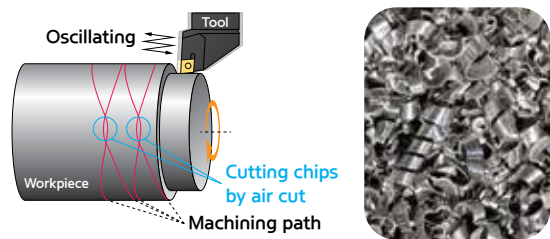

(Developed special screen page for servo learning oscillation function / Even when this function is applied, the cycle time remains same.)

ACAM (Automatic CAM)

Cloud-based automatic CAM S/W that automatically creates NC programs only by inputting drawing files

Cloud-based Intelligent Programming

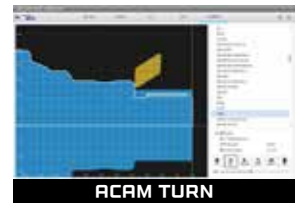
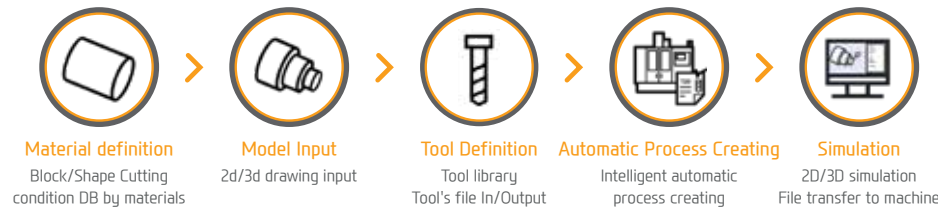

MMS (Machine Monitoring System)



Manufacturing big data solution with design, manufacturing, and intelligence technology of HYUNDAI-WIA (Big data collection/Analysis/Visualization)



1. MMS Cloud

A cloud server-based equipment monitoring system for collecting and analyzing facility operation data.

2. MMS Edge

A client server-based tool monitoring system for collection/analysis of facility operation data. (Compatible with client MES / ERP interface)

SMART CNC (FANUC SMART PLUS)



1. Dialogue Program (Smart Guide-i)

This software offers the maximum user convenience through dialogue manipulation from setup to processing. This includes writing processing programs and simulation checks.

2. LAUNCHER

This software offers shortcuts for quick access to specialized features and frequently used features.

SPECIFICATIONS

Standard & Optional

Spindle		HD2600	HD2600M
12" Headstock		○	-
Main Spindle	10"	●	●
Hollow Chuck 3 Jaw	12"	○	○
Main Spindle	10"	○	○
Solid Chuck 3 Jaw	12"	-	-
Belt Type		●	●
Gear Type		-	-
Standard Soft Jaw (1set)		●	●
Chuck Clamp Foot Switch		●	●
2 Steps Hyd. Pressure Device		○	○
Spindle Inside Stopper		☆	☆
5° Index		-	-
Cs-Axis (0.001°)		-	●
Chuck Open/Close Confirmation Device		●	●
2 Steps Chuck Foot Switch		○	○
Turret			
Tool Holder		●	●
Mill Turret	BMT	-	●
Straight Milling Head	Collet Type,2ea	-	●
Angular Milling Head	Collet Type,2ea	-	●
Straight Milling Head	Adapter Type	-	-
Angular Milling Head	Adapter Type	-	-
Boring Sleeve		●	●
Drill Socket		○	○
U-Drill Holder		●	●
O.D Extension Holder	For Out-Dia	●	●
Angle Head		-	-
Tail Stock & Steady Rest			
Quill Type Tail Stock	MT#4	-	-
	MT#5	●	●
Built-in Tail Stock	MT#4	○	○
Programmable Tail Stock		○	○
Manual Type Hyd. Steady Rest		-	-
Standard Live Center		●	●
High Precision Live Center		☆	☆
2 Steps Tail Stock Pressure System		○	○
Quill Forward/Reverse Confirmation Device		○	○
Tail Stock Foot Switch		○	○
Coolant & Air Blow			
Standard Coolant (Nozzle)		●	●
Chuck Coolant (Upper Chuck)		○	○
Gun Coolant		○	○
Through Spindle Coolant (Only for Special Chuck)		☆	☆
Thru Coolant for Live Tool		-	☆
Chuck Air Blow (Upper Chuck)		○	○
Tail Stock Air Blow (Upper Tail Stock)		○	○
Turret Air Blow		☆	☆
Air Gun		○	○
Through Spindle Air Blow (Only for Special Chuck)		☆	☆
High Pressure Coolant	0.5Bar	●	●
	6Bar	○	○
	20Bar	○	○
Power Coolant System (For Automation)		☆	☆
Coolant Chiller (Only for Sub Tank, Chip Conveyor)		-	-
Chip Disposal			
Coolant Tank	Side	●	●
	Rear	○	○
Chip Conveyor (Hinge/Scraper)	Front (Right)	○	○
	Rear (Rear)	○	○
Special Chip Conveyor (Drum Filter)		☆	☆
Chip Wagon	Standard (180 ℓ [47.5 gal])	○	○
	Swing (200 ℓ [52.8 gal])	○	○
	Large Swing (290 ℓ [76.6 gal])	○	○
	Large Size (330 ℓ [87.2 gal])	○	○
	Customized	☆	☆

● : Standard ○ : Option ☆ : Prior Consultation - : Non Applicable

Safety Device		HD2600	HD2600M
Total Splash Guard		●	●
Electric Device			
Call Light	1Color : ●	●	●
Call Light & Buzzer	3Color : ● ● ● B	○	○
Electric Cabinet Light		○	○
Remote MPG		-	-
Work Counter	Digital	○	○
Total Counter	Digital	○	○
Total Counter	Digital	○	○
Multi Tool Counter	Digital	○	○
Electric Circuit Breaker	FANUC	○	○
	SIEMENS	-	-
AVR (Auto Voltage Regulator)		☆	☆
Transformer	30KVA	○	○
Auto Power Off		○	○
Measurement			
Manual Q-Setter		○	○
Manual Q-Setter (Renishaw)		○	○
Automatic Q-Setter (Renishaw)		○	○
Work Close Confirmation Device (Only for Special Chuck)	TACO	☆	☆
	SMC	☆	☆
Auto Tool Measuring Device		☆	☆
Linear Scale	X Axis	○	○
	Z Axis	○	○
Coolant Level Sensor (Only for Chip Conveyor, bladder Type)		☆	☆
Environment			
Air Conditioner		○	○
Oil Mist Collector		☆	☆
Oil Skimmer (Only for Chip Conveyor)		○	○
MQL (Minimal Quantity Lubrication)		☆	☆
Fixture & Automation			
Auto Door		○	○
Auto Shutter (Only for Automatic System)		☆	☆
Sub Operation Panel		☆	☆
Bar Feeder Interface		○	○
Bar Feeder (FEDEK)		☆	☆
workpusher (Spring type)		○	○
Extra M-Code 4ea		○	○
Automation Interface		☆	☆
I/O Extension (IN & OUT)	16 Contact	○	○
	32 Contact	○	○
Parts Catcher		○	○
Turret Work Pusher (For Automation)		☆	☆
Parts Conveyor (Required Main Parts Catcher)		☆	☆
Semi Automation System		☆	☆
Hyd. Device			
Standard Hyd. Cylinder	Hollow	●	●
Standard Hyd. Unit	35bar/24 ℓ (6.3gal)	●	●
S/W			
Automatic CAM (HW-ACAM)		-	-
Dialogue Program (HW-DPRO)		○	○
DNC software (HW-eDNC)		○	○
Machine Monitoring System (HW-MMS Cloud)		☆	☆
Machine Monitoring System (Customer Installation : HW-MMS Edge)		☆	☆
Smart Guide-i : FANUC		●	●
Smart S/W		☆	☆
ETC			
Tool Box		●	●
Customized Color	Need Munsell No.	☆	☆
CAD & CAM		☆	☆

❖ 4 channel of TDC(Thermal Displacement Compensation) device is recommended, when more than 6 bar of high pressure coolant is applied, for the high quality machining.

Specifications are subject to change without notice for improvement. / Please refer to the S/W catalog (IRIS) for details by S/W product.

SPECIFICATIONS

Standard & Optional

Spindle		HD3100A	HD3100MA
Main Spindle	10"	●	●
Hollow Chuck 3 Jaw	12"	○	○
Main Spindle	10"	○	○
Solid Chuck 3 Jaw	12"	-	-
Belt Type		●	●
Gear Type		-	-
Standard Soft Jaw (1set)		●	●
Chuck Clamp Foot Switch		●	●
2 Steps Hyd. Pressure Device		○	○
Spindle Inside Stopper		☆	☆
5° Index		-	-
Cs-Axis (0.001")		-	●
Chuck Open/Close Confirmation Device		●	●
2 Steps Chuck Foot Switch		○	○
Turret			
Tool Holder		●	●
Mill Turret	BMT	-	●
Straight Milling Head	Collet Type,2ea	-	●
Angular Milling Head	Collet Type,2ea	-	-
Straight Milling Head	Adapter Type	-	-
Angular Milling Head	Adapter Type	-	-
Boring Sleeve		●	●
Drill Socket		○	○
U-Drill Holder		●	●
O.D Extension Holder	For Out-Dia	●	-
Angle Head		-	-
Tail Stock & Steady Rest			
Quill Type Tail Stock	MT#4	-	-
	MT#5	●	●
Built-in Tail Stock	MT#4	○	○
Programmable Tail Stock		○	○
Manual Type Hyd. Steady Rest		-	-
Standard Live Center		●	●
High Precision Live Center		☆	☆
2 Steps Tail Stock Pressure System		○	○
Quill Forward/Reverse Confirmation Device		○	○
Tail Stock Foot Switch		○	○
Coolant & Air Blow			
Standard Coolant (Nozzle)		●	●
Chuck Coolant (Upper Chuck)		○	○
Gun Coolant		○	○
Through Spindle Coolant (Only for Special Chuck)		☆	☆
Thru Coolant for Live Tool		-	☆
Chuck Air Blow (Upper Chuck)		○	○
Tail Stock Air Blow (Upper Tail Stock)		○	○
Turret Air Blow		☆	☆
Air Gun		○	○
Through Spindle Air Blow (Only for Special Chuck)		☆	☆
High Pressure Coolant	0.5Bar	●	●
	6Bar	○	○
	20Bar	○	○
Power Coolant System (For Automation)		☆	☆
Coolant Chiller (Only for Sub Tank, Chip Conveyor)		-	-
Chip Disposal			
Coolant Tank	Side	●	●
	Rear	○	○
Chip Conveyor (Hinge/Scraper)	Front (Right)	○	○
	Rear (Rear)	○	○
Special Chip Conveyor (Drum Filter)		☆	☆
Chip Wagon	Standard (180 ℓ [47.5 gal])	○	○
	Swing (200 ℓ [52.8 gal])	○	○
	Large Swing (290 ℓ [76.6 gal])	○	○
	Large Size (330 ℓ [87.2 gal])	○	○
	Customized	☆	☆

● : Standard ○ : Option ☆ : Prior Consultation - : Non Applicable

Safety Device		HD3100A	HD3100MA
Total Splash Guard		●	●
Electric Device			
Call Light	1Color : ●	●	●
Call Light & Buzzer	3Color : ●●● B	○	○
Electric Cabinet Light		○	○
Remote MPG		-	-
Work Counter	Digital	○	○
Total Counter	Digital	○	○
Tool Counter	Digital	○	○
Multi Tool Counter	Digital	○	○
Electric Circuit Breaker		○	○
AVR (Auto Voltage Regulator)		☆	☆
Transformer	30kVA	○	○
Auto Power Off		○	○
Measurement			
Manual Q-Setter		○	○
Manual Q-Setter (Renishaw)		○	○
Automatic Q-Setter (Renishaw)		○	○
Work Close Confirmation Device (Only for Special Chuck)	TACO	☆	☆
	SMC	☆	☆
Auto Tool Measuring Device		☆	☆
Linear Scale	X Axis	○	○
	Z Axis	○	○
Coolant Level Sensor (Only for Chip Conveyor, bladder Type)		☆	☆
Environment			
Air Conditioner		○	○
Oil Mist Collector		☆	☆
Oil Skimmer (Only for Chip Conveyor)		○	○
MQL (Minimal Quantity Lubrication)		☆	☆
Fixture & Automation			
Auto Door		○	○
Auto Shutter (Only for Automatic System)		☆	☆
Sub Operation Pannel		☆	☆
Bar Feeder Interface		○	○
Bar Feeder (FEDEK)		☆	☆
workpusher (Spring type)		○	○
Extra M-Code 4ea		○	○
Automation Interface		☆	☆
I/O Extension (IN & OUT)	16 Contact	○	○
	32 Contact	○	○
Parts Catcher	Main SP.	○	○
Turret Work Pusher (For Automation)		☆	☆
Parts Conveyor (Required Main Parts Catcher)		☆	☆
Semi Automation System		☆	☆
Hyd. Device			
Standard Hyd. Cylinder	Hollow	●	●
Standard Hyd. Unit	35bar/30 ℓ (7.9gal)	●	●
S/W			
Automatic CAM (HW-ACAM)		-	-
Dialogue Program (HW-DPRO)		○	○
DNC software (HW-eDNC)		○	○
Machine Monitoring System (HW-MMS Cloud)		☆	☆
Machine Monitoring System (Customer Installation : HW-MMS Edge)		☆	☆
Smart Guide-i : FANUC		●	●
Smart S/W		☆	☆
ETC			
Tool Box		●	●
Customized Color	Need Munsell No.	☆	☆
CAD & CAM		☆	☆

◆ 4 channel of TDC(Thermal Displacement Compensation) device is recommended, when more than 6 bar of high pressure coolant is applied, for the high quality machining.

Specifications are subject to change without notice for improvement. / Please refer to the S/W catalog (IRIS) for details by S/W product.

SPECIFICATIONS

Standard & Optional

Spindle		HD3100/L	HD3100M/LM
Main Spindle	12"	●	●
Hollow Chuck 3 Jaw	15"	-	-
Main Spindle	12"	-	-
Solid Chuck 3 Jaw	15"	-	-
Belt Type		●	●
Gear Type		○	-
Standard Soft Jaw (1set)		●	●
Chuck Clamp Foot Switch		●	●
2 Steps Hyd, Pressure Device		○	○
Spindle Inside Stopper		☆	☆
5" Index		☆	☆
Cs-Axis (0.001°)		-	●
Chuck Open/Close Confirmation Device		●	●
2 Steps Chuck Foot Switch		○	○
Turret			
Tool Holder		●	●
Mill Turret	BMT	-	●
Straight Milling Head	Collet Type,2ea	-	●
Angular Milling Head	Collet Type,2ea	-	●
Straight Milling Head	Adapter Type	-	-
Angular Milling Head	Adapter Type	-	-
Boring Sleeve		●	●
Drill Socket		○	○
U-Drill Holder		●	●
O.D Extension Holder	For Out-Dia	●	-
Angle Head		-	-
Tail Stock & Steady Rest			
Quill Type Tail Stock	MT#4	-	-
	MT#5	●	●
Built-in Tail Stock	MT#4	○	○
Programmable Tail Stock		○	○
Manual Type Hyd. Steady Rest		-	-
Standard Live Center		●	●
High Precision Live Center		☆	☆
2 Steps Tail Stock Pressure System		○	○
Quill Forward/Reverse Confirmation Device		○	○
Tail Stock Foot Switch		○	○
Coolant & Air Blow			
Standard Coolant (Nozzle)		●	●
Chuck Coolant (Upper Chuck)		○	○
Gun Coolant		○	○
Through Spindle Coolant (Only for Special Chuck)		☆	☆
Thru Coolant for Live Tool		-	☆
Chuck Air Blow (Upper Chuck)		○	○
Tail Stock Air Blow (Upper Tail Stock)		○	○
Turret Air Blow		☆	☆
Air Gun		○	○
Through Spindle Air Blow (Only for Special Chuck)		☆	☆
High Pressure Coolant	0.5Bar	●	●
	6Bar	○	○
	20Bar	○	○
Power Coolant System (For Automation)		☆	☆
Coolant Chiller (Only for Sub Tank, Chip Conveyor)		-	-
Chip Disposal			
Coolant Tank	Side	●	●
	Rear	○/-	○/-
Chip Conveyor (Hinge/Scraper)	Front (Right)	○	○
	Rear (Rear)	○/-	○/-
Special Chip Conveyor (Drum Filter)		☆	☆
Chip Wagon	Standard (180 ℓ [47.5 gal])	○	○
	Swing (200 ℓ [52.8 gal])	○	○
	Large Swing (290 ℓ [76.6 gal])	○	○
	Large Size (330 ℓ [87.2 gal])	○	○
	Customized	☆	☆

● : Standard ○ : Option ☆ : Prior Consultation - : Non Applicable

Safety Device		HD3100/L	HD3100M/LM
Total Splash Guard		●	●
Electric Device			
Call Light	1Color : ●	●	●
Call Light & Buzzer	3Color : ● ● ● B	○	○
Electric Cabinet Light		○	○
Remote MPG		-	-
Work Counter	Digital	○	○
Total Counter	Digital	○	○
Tool Counter	Digital	○	○
Multi Tool Counter	Digital	○	○
Electric Circuit Breaker		○	○
AVR (Auto Voltage Regulator)		☆	☆
Transformer	30kVA (Belt)	○	○
	35kVA (Gear)	○	○
Auto Power Off		○	○
Measurement			
Manual Q-Setter		○	○
Manual Q-Setter (Renishaw)		○	○
Automatic Q-Setter (Renishaw)		○	○
Work Close Confirmation Device (Only for Special Chuck)	TACO	☆	☆
	SMC	☆	☆
Auto Tool Measuring Device		☆	☆
Linear Scale	X Axis	○	○
	Z Axis	○	○
Coolant Level Sensor (Only for Chip Conveyor, bladder Type)		☆	☆
Environment			
Air Conditioner		○	○
Oil Mist Collector		☆	☆
Oil Skimmer (Only for Chip Conveyor)		○	○
MQL (Minimal Quantity Lubrication)		☆	☆
Fixture & Automation			
Auto Door		○	○
Auto Shutter (Only for Automatic System)		☆	☆
Sub Operation Panel		☆	☆
Bar Feeder Interface		○	○
Bar Feeder (FEDEK)		☆	☆
workpusher (Spring type)		○	○
Extra M-Code 4ea		○	○
Automation Interface		☆	☆
I/O Extension (IN & OUT)	16 Contact	○	○
	32 Contact	○	○
Parts Catcher	Main SP.	○	○
Turret Work Pusher (For Automation)		☆	☆
Parts Conveyor (Required Main Parts Catcher)		☆	☆
Semi Automation System		☆	☆
Hyd. Device			
Standard Hyd. Cylinder	Hollow	●	●
Standard Hyd. Unit	35bar/30ℓ (7.9gal)	●	●
S/W			
Automatic CAM (HW-ACAM)		-	-
Dialogue Program (HW-DPRO)		○	○
DNC software (HW-eDNC)		○	○
Machine Monitoring System (HW-MMS Cloud)		☆	☆
Machine Monitoring System (Customer Installation : HW-MMS Edge)		☆	☆
Smart Guide-i : FANUC		●	●
Smart S/W		☆	☆
ETC			
Tool Box		●	●
Customized Color	Need Munsell No.	☆	☆
CAD & CAM		☆	☆

❖ 4 channel of TDC(Thermal Displacement Compensation) device is recommended, when more than 6 bar of high pressure coolant is applied, for the high quality machining.

Specifications are subject to change without notice for improvement. / Please refer to the S/W catalog (IRIS) for details by S/W product.

SPECIFICATIONS

Spindle-Turret Output/Torque Diagram (HD2600 Series)

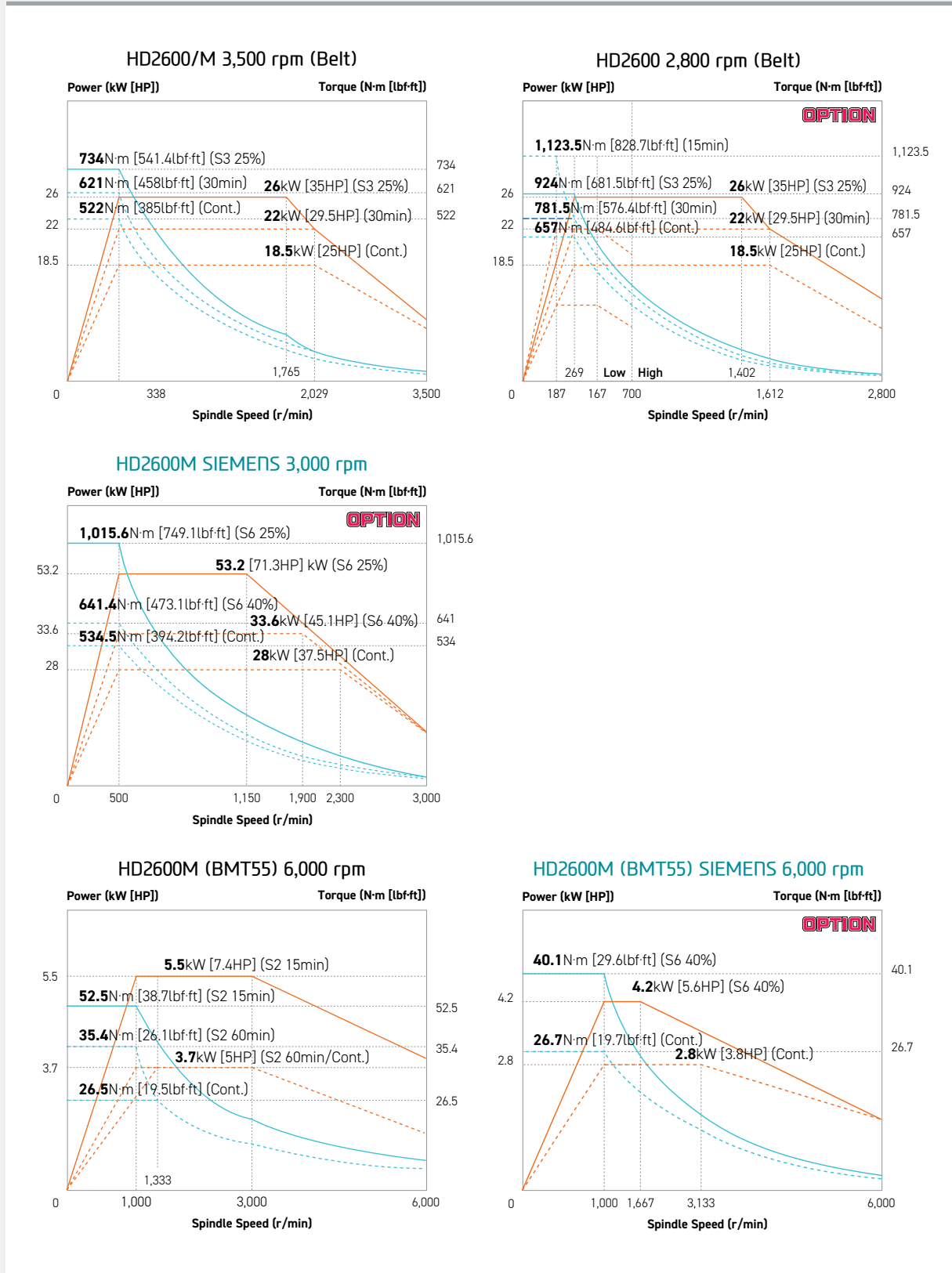

SPECIFICATIONS

Spindle-Turret Output/Torque Diagram (HD3100 Series)

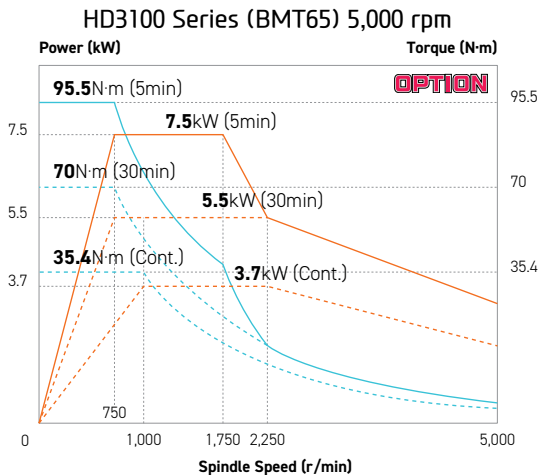
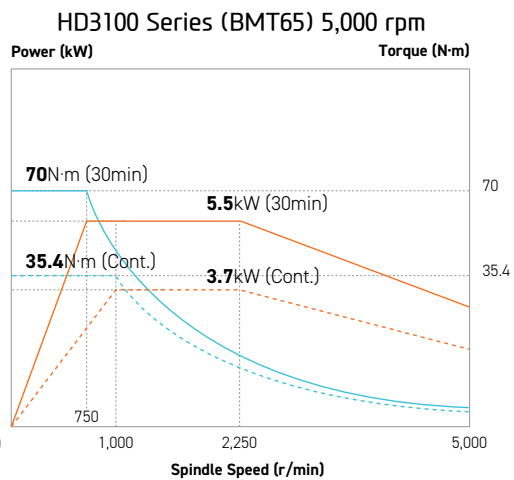
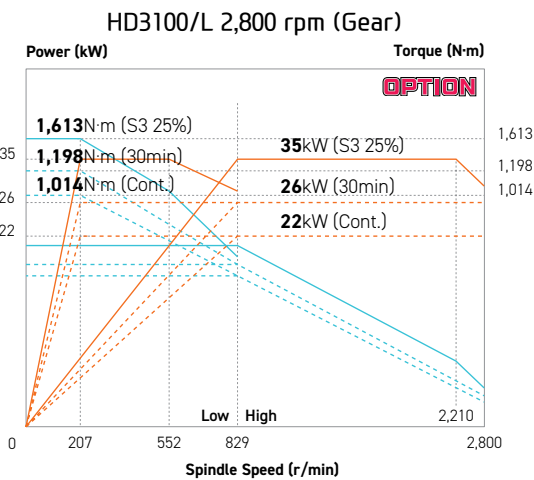
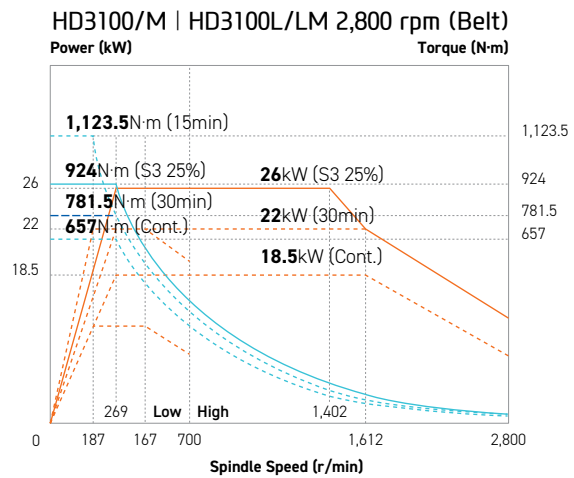
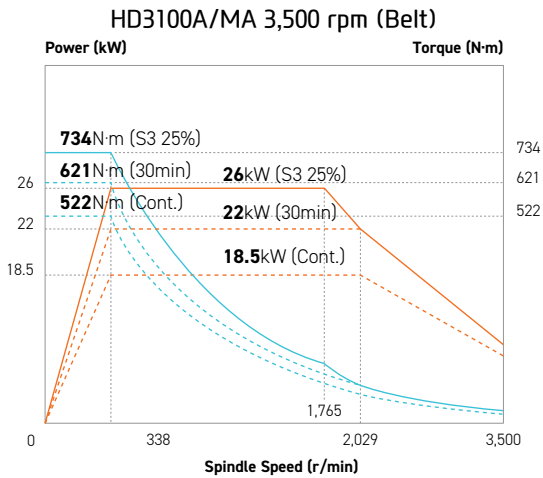

SPECIFICATIONS

External Dimensions

unit : mm(in)

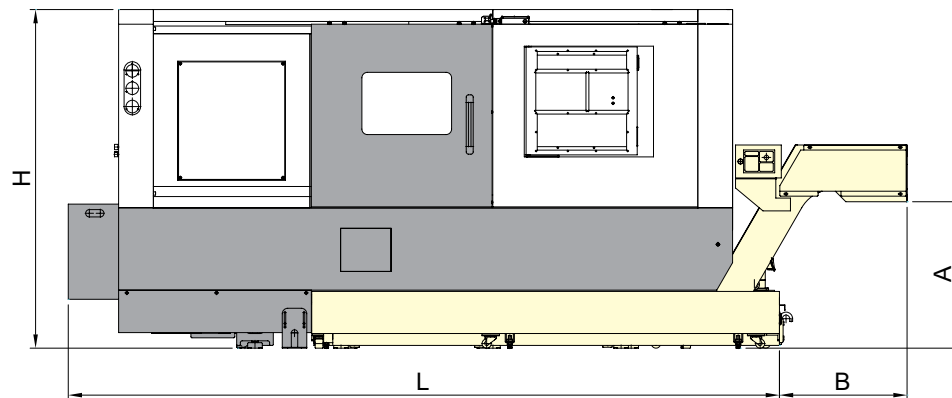
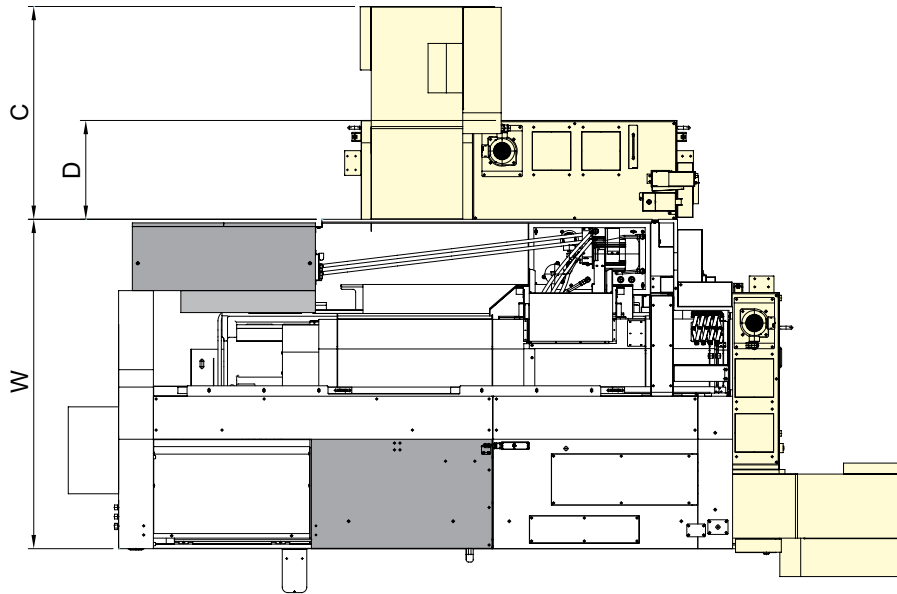

Dimension		HD2600	HD2600M	HD3100A	HD3100MA	HD3100	HD3100M	HD3100L	HD3100LM
Length	L	3,400 (133.9")		3,885 (153")			4,405 (173.4")		
Length (Gear Spindle Opt.)		-		-	4,045 (159.2")	-	4,565 (179.7")	-	
Width	W	1,708 (67.2")		1,800 (70.9")			1,978 (77.9")		
Height	H	1,755 (69.1")		1,850 (72.8")					
Conveyor height	A	1,200 (47.2") or 850 (33.5") [Opt.]							
Side type chip conveyor	B	1,120 (44.1")		900 (35.4")			980 (38.6")		
Rear type chip conveyor	C	1,210 (47.6")		1,120 (44.1")			-		
Rear tank	D	630 (24.8")		540 (21.3")			-		

SPECIFICATIONS

Tooling System

unit : mm(in)

□ Option

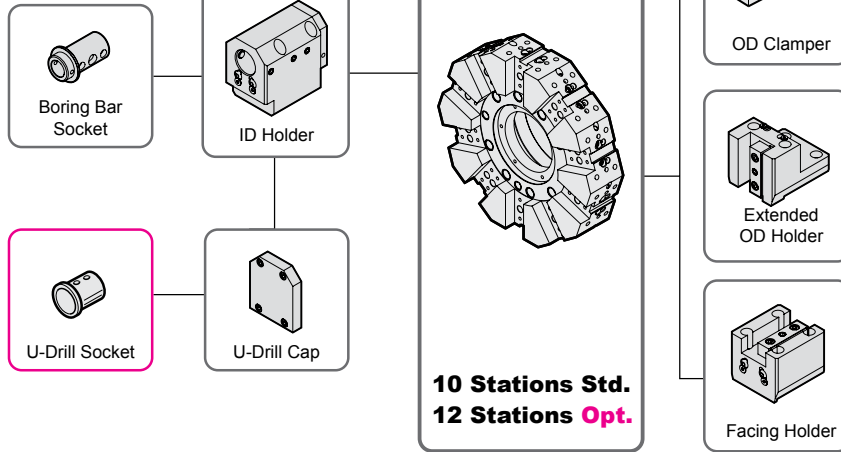

Tooling Parts Detail

ITEM			HD2600		HD3100A		HD3100		HD3100L	
			mm Unit	inch Unit	mm Unit	inch Unit	mm Unit	inch Unit	mm Unit	inch Unit
Turning Holder	O.D Holder	Right/Left	-	-	-	-	-	-	-	-
		Extension	1	1	1	1	1	1	1	1
	Facing Holder		1	1	1	1	1	1	1	1
Boring Holder	I.D Holder	Single	5	5	5	5	5	5	5	5
	U-Drill Holder	Cap	1	1	1	1	1	1	1	1
Driven Holder	Straight Mill Holder	Standard	-	-	-	-	-	-	-	-
		TTC	-	-	-	-	-	-	-	-
	Angular Mill Holder	Standard	-	-	-	-	-	-	-	-
		TTC	-	-	-	-	-	-	-	-
Socket	Boring	Ø12 (Ø1/2")	1	1	1	1	1	1	1	1
		Ø16 (Ø5/8")	1	1	1	1	1	1	1	1
		Ø20 (Ø3/4")	1	1	1	1	1	1	1	1
		Ø25 (Ø1")	1	1	1	1	1	1	1	1
		Ø32 (Ø1 1/4")	1	1	1	1	1	1	1	1
		Ø40 (Ø1 1/2")	1	1	1	1	1	1	1	1
	Drill	MT 1 x MT 2	Opt.	Opt.	Opt.	Opt.	Opt.	Opt.	Opt.	Opt.
		MT 2	Opt.	Opt.	Opt.	Opt.	Opt.	Opt.	Opt.	Opt.
		MT 3	Opt.	Opt.	Opt.	Opt.	Opt.	Opt.	Opt.	Opt.
		MT 4	Opt.	Opt.	Opt.	Opt.	Opt.	Opt.	Opt.	Opt.
	ER Collet		-	-	-	-	-	-	-	-

SPECIFICATIONS

Tooling System

unit : mm(in)

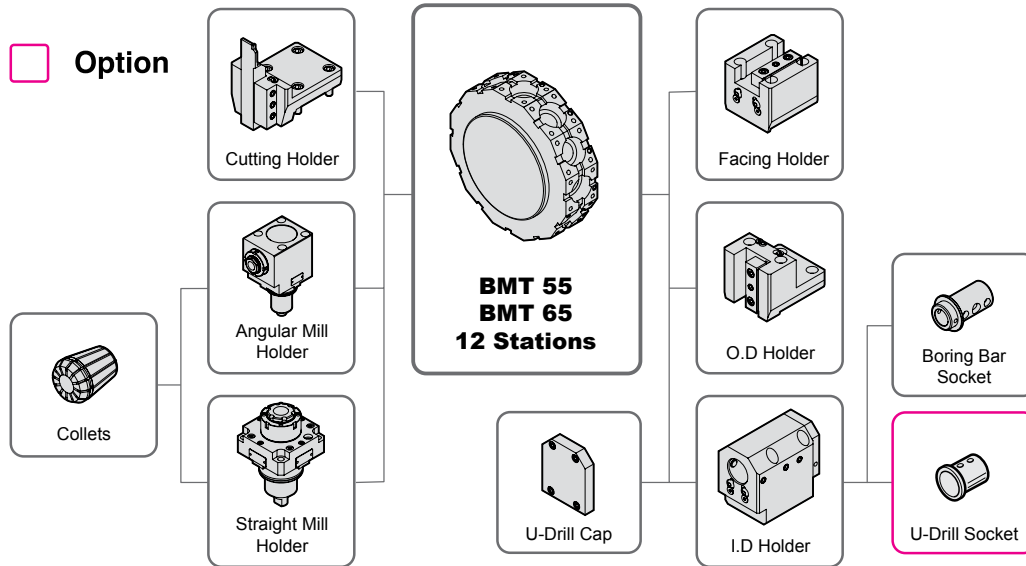

Tooling Parts Detail

ITEM			HD2600M		HD3100MA		HD3100M		HD3100LM	
			mm Unit	inch Unit	mm Unit	inch Unit	mm Unit	inch Unit	mm Unit	inch Unit
Turning Holder	O.D Holder	Right/Left	4	4	4	4	4	4	4	4
	Cutting Holder		-	-	-	-	-	-	-	-
	Facing Holder		1	1	1	1	1	1	1	1
Boring Holder	I.D Holder	Single	3	3	3	3	3	3	3	3
	U-Drill	Cap	1	1	1	1	1	1	1	1
Driven Holder	Straight Mill Holder	Standard	2	2	2	2	2	2	2	2
		TTC	-	-	-	-	-	-	-	-
	Angular Mill Holder	Standard	2	2	2	2	2	2	2	2
		TTC	-	-	-	-	-	-	-	-
Socket	Boring	Ø10 (Ø3/8")	1	1	-	-	-	-	-	-
		Ø12 (Ø1/2")	1	1	1	1	1	1	1	1
		Ø16 (Ø5/8")	1	1	1	1	1	1	1	1
		Ø20 (Ø3/4")	1	1	1	1	1	1	1	1
		Ø25 (Ø1")	1	1	1	1	1	1	1	1
		Ø32 (Ø1 1/4")	1	1	1	1	1	1	1	1
		Ø40 (Ø1 1/2")	-	-	1	1	1	1	1	1
	Drill	MT 1 x MT 2	Opt.	Opt.	Opt.	Opt.	Opt.	Opt.	Opt.	Opt.
		MT 2	Opt.	Opt.	Opt.	Opt.	Opt.	Opt.	Opt.	Opt.
		MT 3	Opt.	Opt.	Opt.	Opt.	Opt.	Opt.	Opt.	Opt.
		MT 4	-	-	Opt.	Opt.	Opt.	Opt.	Opt.	Opt.
	ER Collet		1 Set	1 Set	1 Set	1 Set	1 Set	1 Set	1 Set	1 Set
	Adapter Set		Opt.	Opt.	Opt.	Opt.	Opt.	Opt.	Opt.	Opt.

Specifications are subject to change without notice for improvement. (HD3100 Series - I.D. Tool Holder Single/U-drill <Combined Use>)

SPECIFICATIONS

Tooling Travel Range

unit : mm(in)

HD2600

Tool Holder

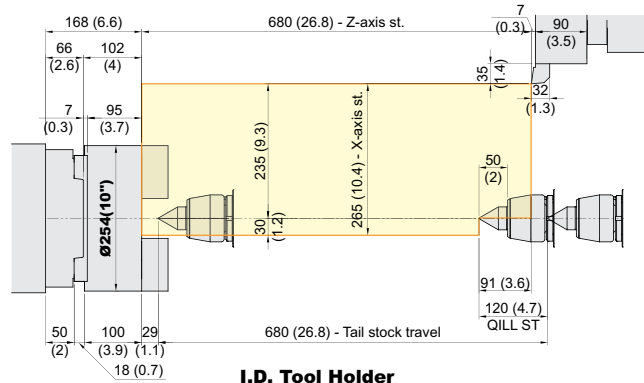

I.D. Tool Holder

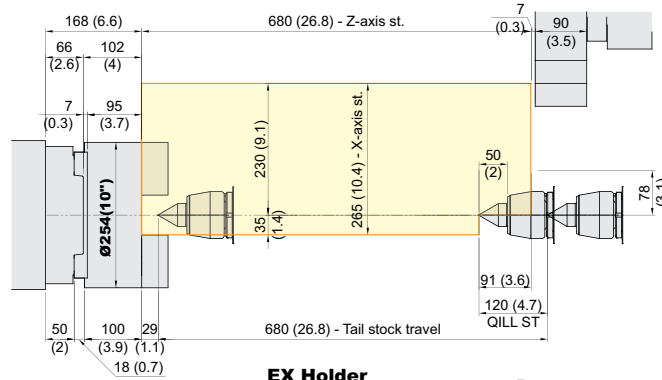

EX Holder

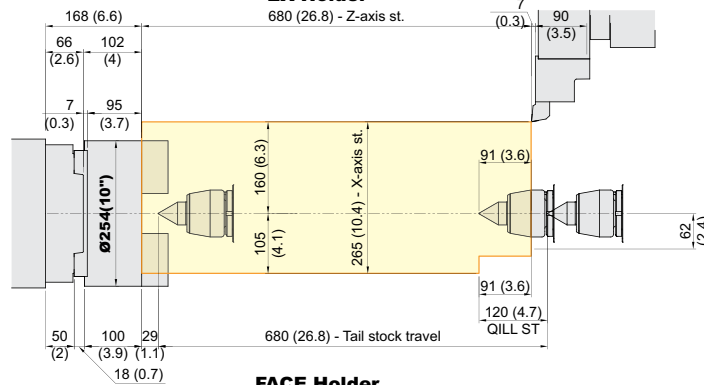

FACE Holder

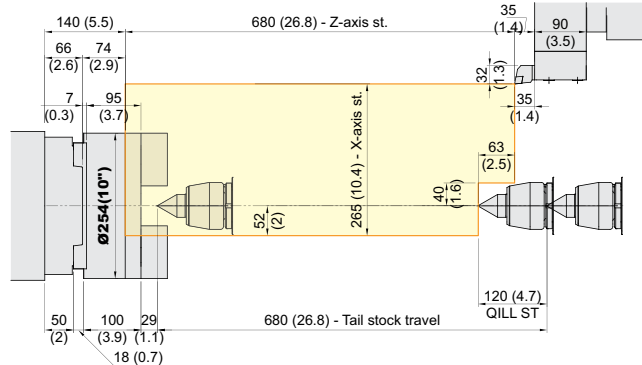

SPECIFICATIONS

Tooling Travel Range

unit : mm(in)

HD2600M

O.D. Tool Holder

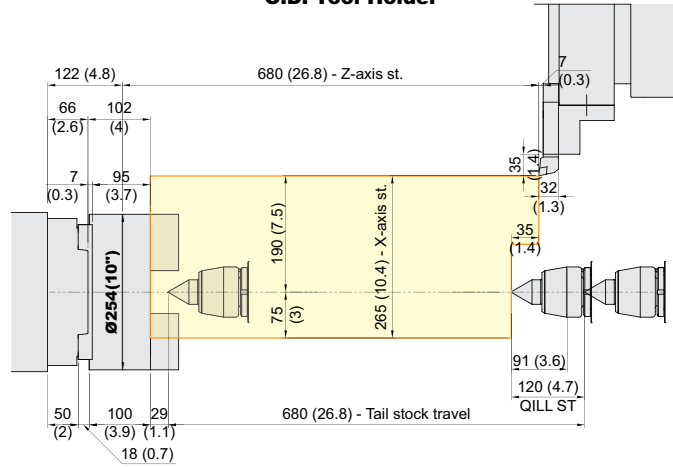

I.D. Tool Holder

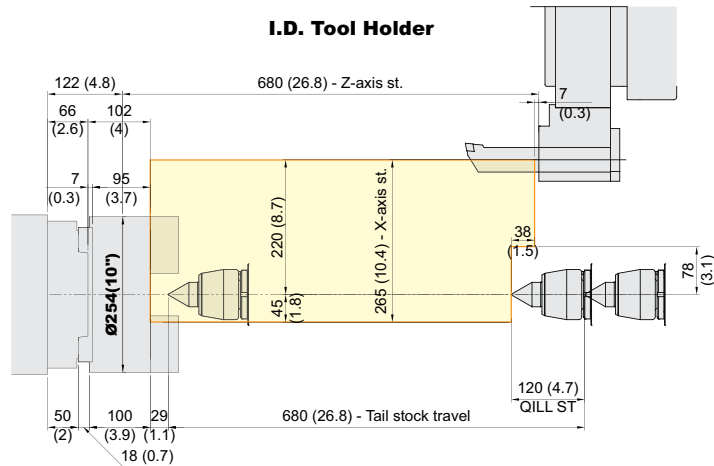

Straight Mill Holder

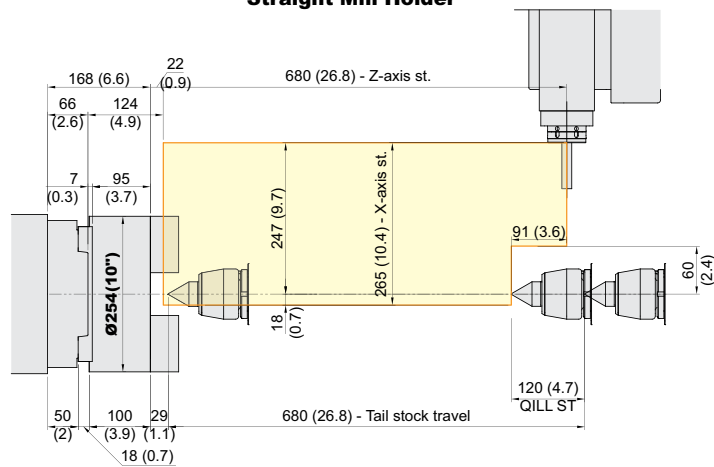

SPECIFICATIONS

Tooling Travel Range

unit : mm(in)

HD3100A | HD3100

O.D. Tool Holder

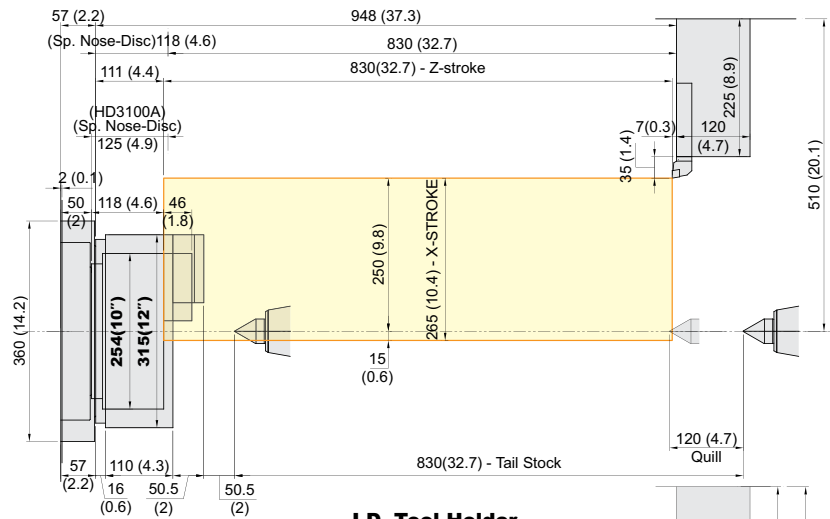

I.D. Tool Holder

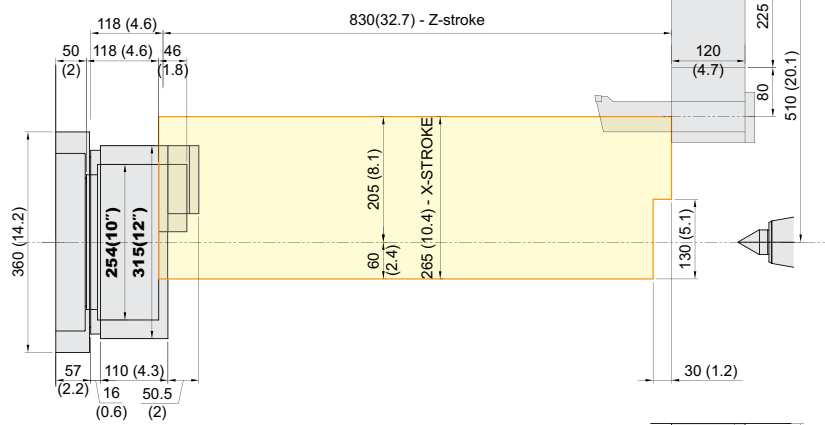

Face Tool Holder

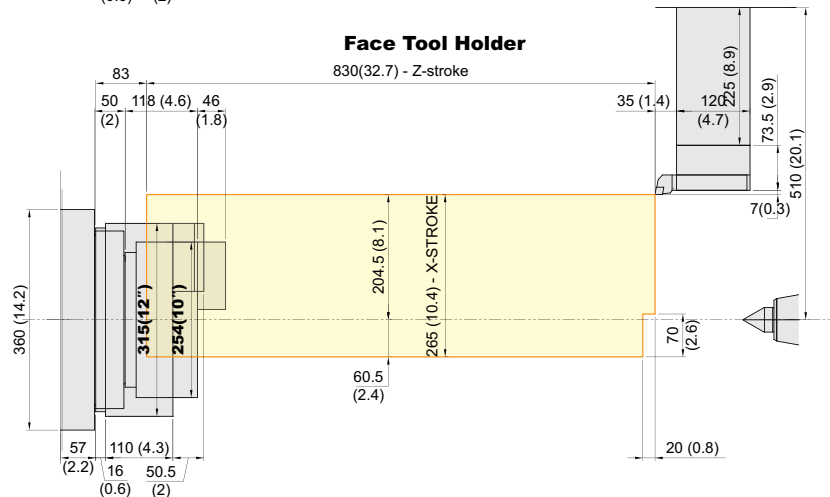

SPECIFICATIONS

Tooling Travel Range

unit : mm(in)

HD3100MA | HD3100M

O.D. Tool Holder

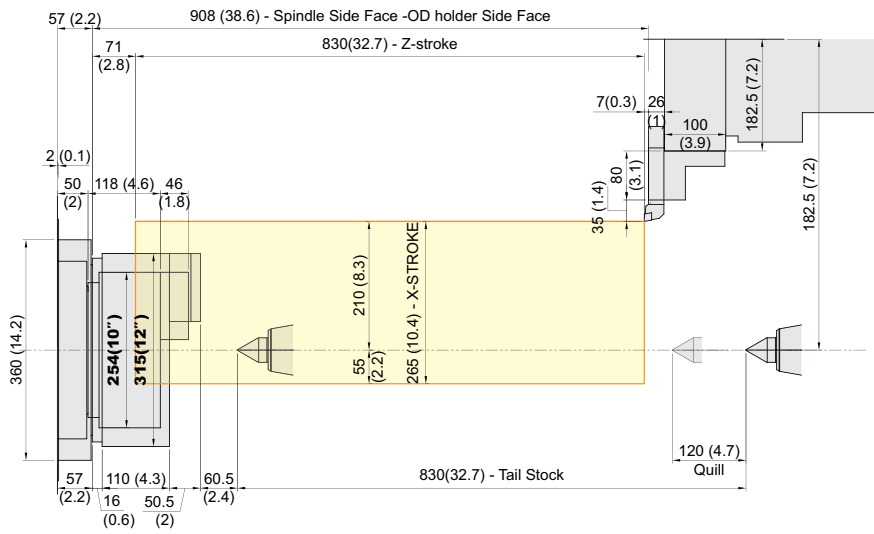

I.D. Tool Holder

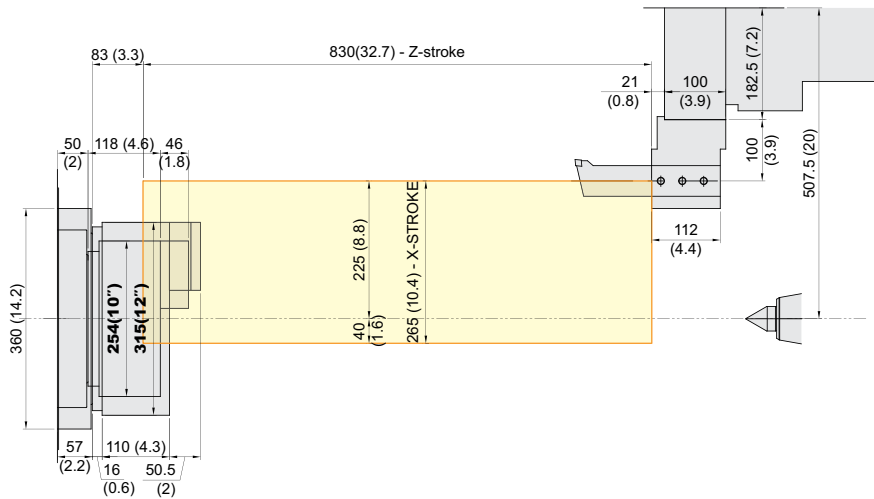

SPECIFICATIONS

Tooling Travel Range

unit : mm(in)

HD3100MA | HD3100M

Face Tool Holder

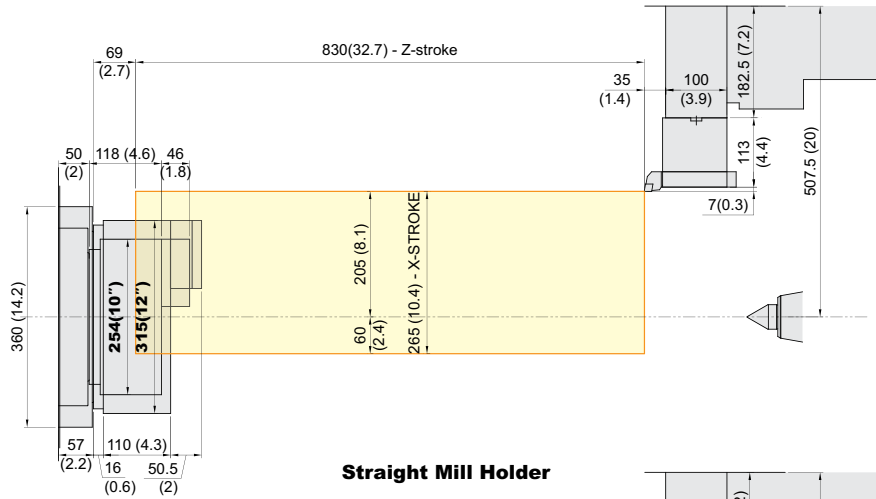

Straight Mill Holder

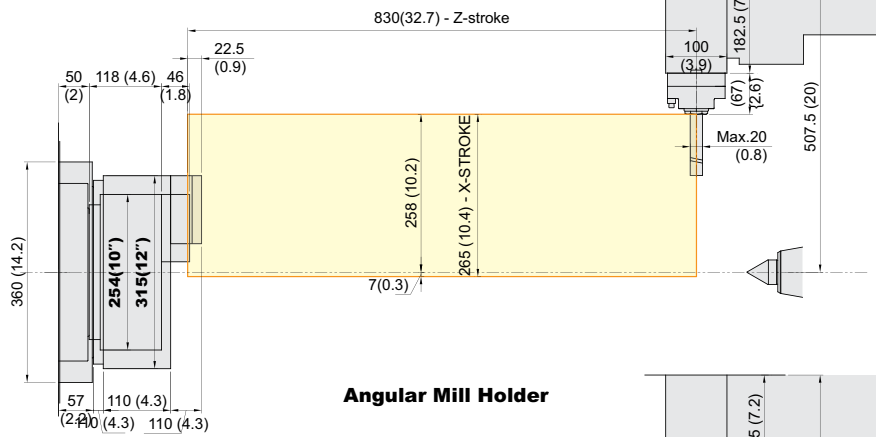

Angular Mill Holder

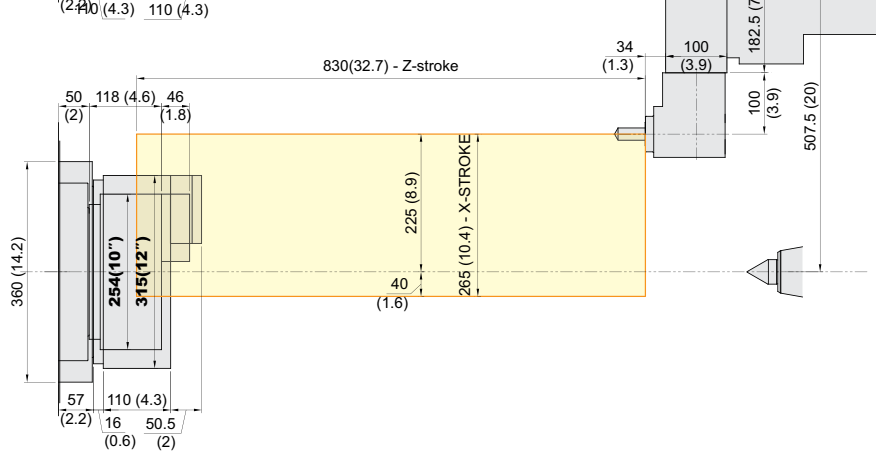

SPECIFICATIONS

Tooling Travel Range

unit : mm(in)

HD3100LM

O.D. Tool Holder

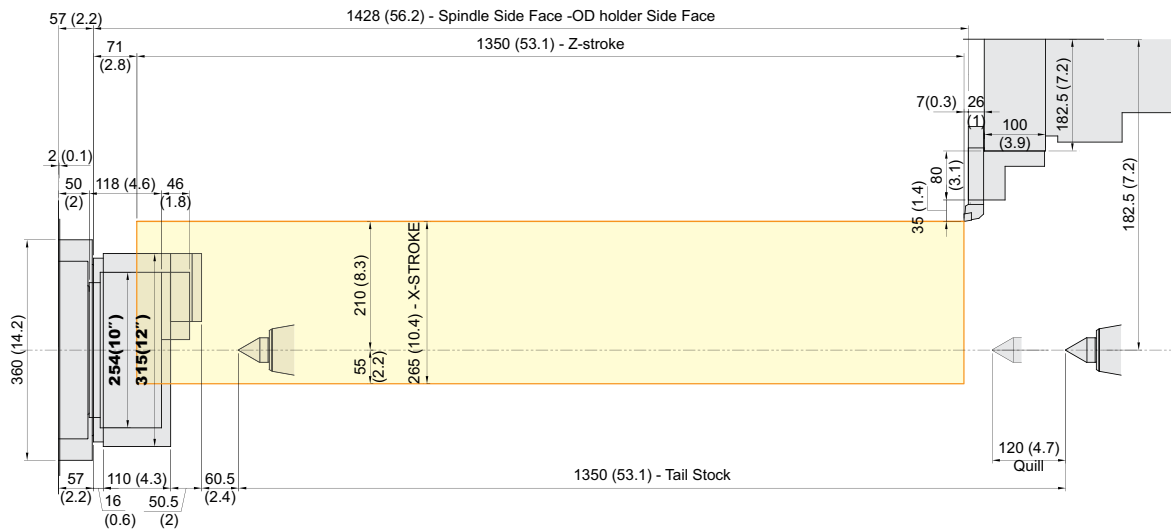

I.D. Tool Holder

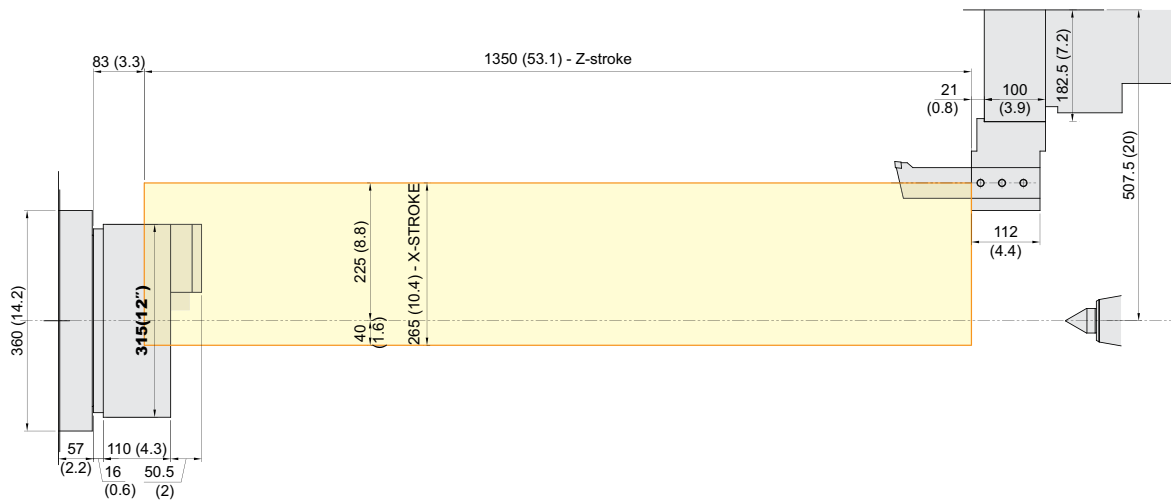

SPECIFICATIONS

Tooling Travel Range

unit : mm(in)

HD3100LM

Face Tool Holder

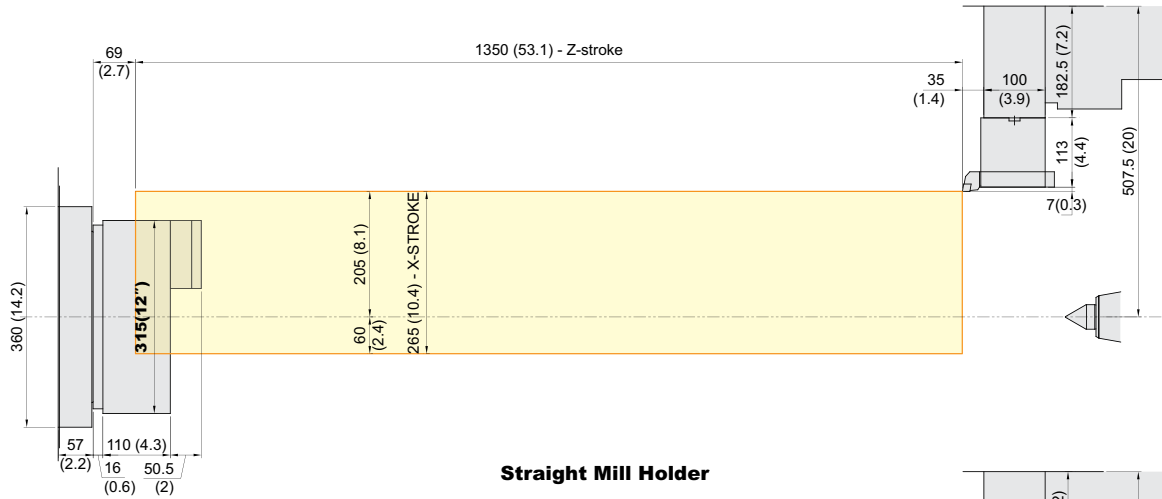

Straight Mill Holder

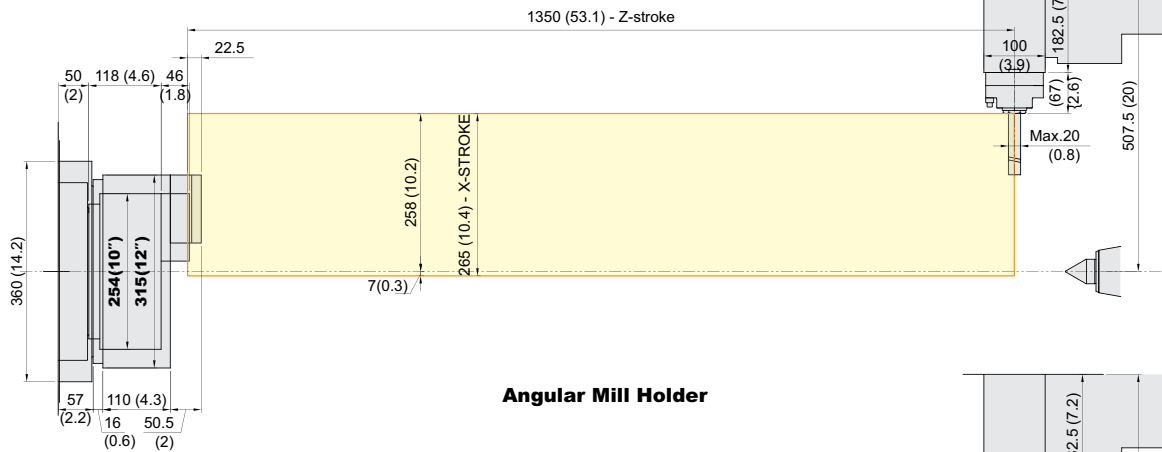

Angular Mill Holder

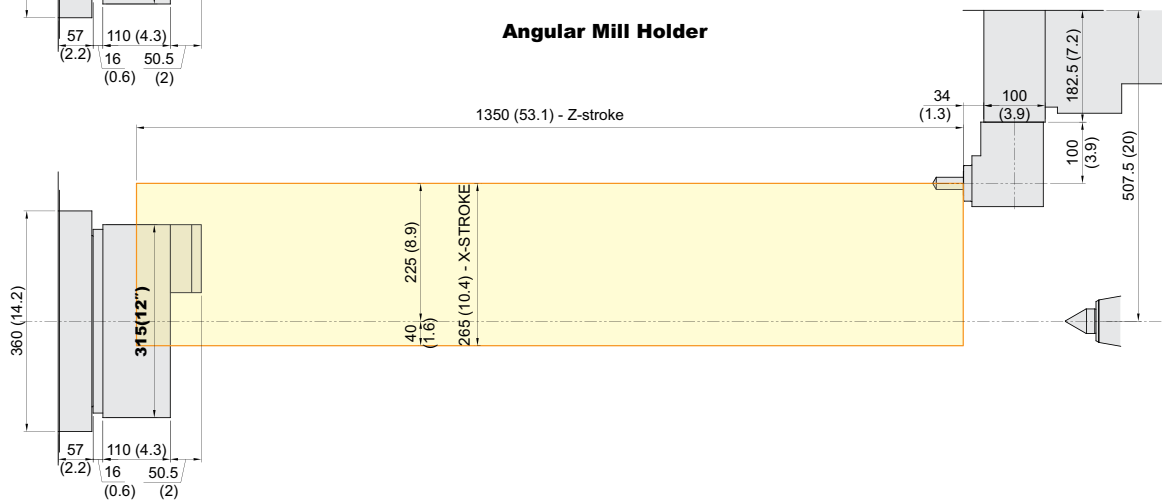

SPECIFICATIONS

Specifications

[] : Option

MODEL		HD2600	HD2600M	
CAPACITY	Swing Over the Bed	mm(in)	Ø630 (24.8")	
	Swing Over the Carriage	mm(in)	Ø460 (18.1")	
	Max. Turning Dia.	mm(in)	Ø460 (18.1")	Ø380 (15")
	Max. Turning Length	mm(in)	659 (25.9")	613 (24.1")
	Bar Capacity	mm(in)	Ø81 (3.2")	
SPINDLE	Chuck Size	inch	10" [12"]	10"
	Spindle Bore	mm(in)	Ø91 (3.6")	
	Spindle Speed (rpm)	r/min	3,500 [2,800]	3,500 [2,800]
	Motor (Max/Cont.)	kW(HP)	26/18.5 (35/25) [26/18.5 (35/25)]	26/18.5 (35/25) [53.2/28 (71.3/37.5)]
	Torque (Max/Cont.)	N·m (lbfft)	734/522 (541.4/385) [1,123/657 (828.7/484.6)]	734/522 (541.4/385) [1,015/534.5 (749.1/394.2)]
	Spindle Type	-	BELT	
	Spindle Nose	-	A2-8	
	C-axis Indexing	deg	-	0.001°
FEED	Travel (X/Z)	mm(in)	265/680 (10.4"/26.8")	
	Rapid Traverse Rate (X/Z)	m/min (ipm)	24/30 (94.5/1,181)	
	Slide Type	-	BOX GUIDE	
TURRET	No. of Tools	ea	10 [12]	12
	Tool Size	OD	mm(in)	□ 25 (□ 1")
		ID	mm(in)	Ø50 (Ø2")
	Indexing Time	sec	0.15	
LIVE TOOL	Motor (Max/Cont.)	kW(HP)	-	5.5/3.7 (7.4/5) [4.2/2.8]
	Milling Tool Speed (rpm)	r/min	-	6,000 [6,000]
	Torque (Max/Cont.)	N·m (lbfft)	-	52.5/26.5 (38.7/19.5) [40.1/26.7]
	Collet Size	mm(in)	-	Ø16 (0.6") - ER25
	Type	-	-	BMT55P
TAIL STOCK	Taper	-	MT#5 [BUILT-IN TAIL STOCK : MT#4]	
	Quill Dia.	mm(in)	Ø100 (3.9)	
	Quill Travel	mm(in)	120 (4.7")	
	Travel	mm(in)	680 (26.8")	
TANK CAPACITY	Coolant Tank	ℓ(gal)	180 (47.6)	
	Lubricating Tank	ℓ(gal)	1.8 (0.5)	
POWER SUPPLY	Electric Power Supply	kVA	27	
	Thickness of Power Cable	mm ²	Over 16	
	Voltage	V/Hz	220/60 (200/50)	
MACHINE	Floor Space (L×W)	mm(in)	3,400×1,708 (133.9"×37.2")	
	Height	mm(in)	1,755 (69.1")	
	Weight	kg(lb)	5,800 (12,787)	5,850 (12,897)
NC	Controller	-	H/W FANUC i Series - Smart Plus	H/W FANUC i Series - Smart Plus [SIEMENS 828D]

Specifications are subject to change without notice for improvement.

SPECIFICATIONS

Specifications

[] : Option

MODEL		HD3100A	HD3100MA	
CAPACITY	Swing Over the Bed	mm(in)	Ø750 (29.5")	
	Swing Over the Carriage	mm(in)	Ø500 (19.7")	
	Max. Turning Dia.	mm(in)	Ø500 (19.7")	Ø420 (16.5")
	Max. Turning Length	mm(in)	780 (30.7")	740 (29.1)
	Bar Capacity	mm(in)	Ø81 (3.2")	
SPINDLE	Chuck Size	inch	10"	
	Spindle Bore	mm(in)	Ø91 (3.6")	
	Spindle Speed (rpm)	r/min	3,500	
	Motor (Max/Cont.)	kW(HP)	26/18.5 (35/25)	
	Torque (Max/Cont.)	N·m (lb·ft)	734/522 (541.4/385)	
	Spindle Type	-	BELT	
	Spindle Nose	-	A2-8	
	C-axis Indexing	deg	-	0.001°
FEED	Travel (X/Z)	mm(in)	265/830 (10.4"/32.7")	
	Rapid Traverse Rate (X/Z)	m/min (ipm)	24/30 (945/1,181)	
	Slide Type	-	BOX GUIDE	
TURRET	No. of Tools	ea	10 [12]	12
	Tool Size	OD	mm(in)	□ 25 (□ 1")
		ID	mm(in)	Ø50 (Ø2")
	Indexing Time	sec	0.15	
LIVE TOOL	Motor (Max/Cont.)	kW(HP)	-	5.5/3.7 (7.4/5) [7.5/3.7 (10/5)]
	Milling Tool Speed (rpm)	r/min	-	5,000
	Torque (Max/Cont.)	N·m (lb·ft)	-	70/35.4 (51.6/26.1) [95.5/35.4 (70.4/26.1)]
	Collet Size	mm(in)	-	Ø25 (1") - ER32
	Type	-	-	BMT65P
TAIL STOCK	Taper	-	MT#5 [BUILT-IN TAIL STOCK : MT#4]	
	Quill Dia.	mm(in)	Ø100 (3.9)	
	Quill Travel	mm(in)	120 (4.7")	
	Travel	mm(in)	830 (32.7")	
TANK CAPACITY	Coolant Tank	ℓ(gal)	200 (52.8)	
	Lubricating Tank	ℓ(gal)	1.8 (0.5)	
POWER SUPPLY	Electric Power Supply	kVA	27	
	Thickness of Power Cable	mm ²	Over 16	
	Voltage	V/Hz	220/60 (200/50)	
MACHINE	Floor Space (L×W)	mm(in)	3,885×1,800 (153"×70.9")	
	Height	mm(in)	1,850 (72.8")	
	Weight	kg(lb)	5,950 (13,116)	6,000 (13,228)
PC	Controller	-		

CONTROLLER

Specifications

[] : Option

MODEL		HD3100	HD3100L	HD3100M	HD3100LM	
CAPACITY	Swing Over the Bed	mm(in)	Ø750 (29.5")			
	Swing Over the Carriage	mm(in)	Ø500 (19.7")			
	Max. Turning Dia.	mm(in)	Ø500 (19.7")		Ø420 (16.5")	
	Max. Turning Length	mm(in)	780 (30.7")	1,300 (51.2")	740 (29.1")	1,260 (49.6")
	Bar Capacity	mm(in)	Ø102 (4")			
SPINDLE	Chuck Size	inch	12"			
	Spindle Bore	mm(in)	Ø115 (4.5")			
	Spindle Speed (rpm)	r/min	2,800 [2,800]		2,800	
	Motor (Max/Cont.)	kW(HP)	26/18.5 (35/25) [35/22 (47/29.5)]		26/18.5 (35/25)	
	Torque (Max/Cont.)	N·m (lbfft)	1,123/657 (828.7/484.6) [1,613/1,014 (1,189.7/747.9)]		1,123/657 (828.7/484.6)	
	Spindle Type	-	BELT [GEAR]		BELT	
	Spindle Nose	-	A2-11			
	C-axis Indexing	deg	-		0.001°	
FEED	Travel (X/Z)	mm(in)	265/830 (10.4"/32.7")	265/1,350 (10.4"/53.1")	265/830 (10.4"/32.7")	265/1,350 (10.4"/53.1")
	Rapid Traverse Rate (X/Z)	m/min (ipm)	24/30 (945/1,181)			
	Slide Type	-	BOX GUIDE			
TURRET	No. of Tools	ea	10 [12]		12	
	Tool Size	OD	mm(in)	□ 25 (□ 1")		
		ID	mm(in)	Ø50 (Ø2")		
	Indexing Time	sec	0.15			
LIVE TOOL	Motor (Max/Cont.)	kW(HP)	-		5.5/3.7 (7.4/5) [7.5/3.7 (10/5)]	
	Milling Tool Speed (rpm)	r/min	-		5,000	
	Torque (Max/Cont.)	N·m (lbfft)	-		70/35.4 (51.6/26.1) [95.5/35.4 (70.4/26.1)]	
	Collet Size	mm(in)	-		Ø25 (1") - ER32	
	Type	-	-		BMT65P	
TAIL STOCK	Taper	-	MT#5			
	Quill Dia.	mm(in)	Ø100 (3.9")			
	Quill Travel	mm(in)	120 (4.7")			
	Travel	mm(in)	830 (32.7")	1,350 (53.1")	830 (32.7")	1,350 (53.1")
TANK CAPACITY	Coolant Tank	ℓ(gal)	200 (52.8)	220 (58.1)	200 (52.8)	220 (58.1)
	Lubricating Tank	ℓ(gal)	1.8 (0.5)			
POWER SUPPLY	Electric Power Supply	kVA	Belt : 27 [Gear : 30]		27	
	Thickness of Power Cable	mm ²	Over 16			
	Voltage	V/Hz	220/60 (200/50)			
MACHINE	Floor Space (L×W)	mm(in)	3,885×1,800 (153"×70.9")	4,405×1,978 (173.4"×77.9")	3,885×1,800 (153"×70.9")	4,405×1,978 (173.4"×77.9")
	Height	mm(in)	1,850 (72.8")			
	Weight	kg(lb)	6,000 (13,228)	7,200 (15,873)	6,050 (13,338)	7,250 (15,984)
PC	Controller	-	HYUNDAI WIA FANUC i Series - SMART PLUS			

* Prior consultation is required when applying spindle contouring control for gear driven spindle.
Specifications are subject to change without notice for improvement.

CONTROLLER

HYUNDAI WIA FANUC i Series – Smart Plus

[] : Option

Controlled axis / Display / Accuracy Compensation	
Control axis	2 axis (X, Z) / 3 axis (X, Z, C) / 4 axis (X, Z, Y, C) 5 axis (X, Z, B, C, A) / 6 axis (X, Z, Y, B, C, A) 7 axis (X1/Z1, X2/Z2, B2, C1/C2)
Simultaneously controlled axis	2 axis [Max. 4 axis]
Designation of spindle axis	3 axis [Max. 4 axis] X, Z, Y, B axis : 0.001 mm (0.0001 inch)
Least setting Unit	C, A axis : 0.001 deg
Least input increment	X, Z, Y, B axis : 0.001 mm (0.0001 inch) C, A axis : 0.001 deg
Inch / Metric conversion	G20 / G21
High response vector control	
Interlock	All axis / Each axis
Machine lock	All axis
Backlash compensation	± 0~9999 pulses (exc. Rapid traverse / Cutting feed)
Position switch	
LCD / MDI	15 inch LCD unit (with Touch Panel)
Feedback	Absolute motor feedback
Stored stroke check 1	Over travel
Stored stroke check 2, 3	
PMC axis control	
Operation	
Automatic operation (Memory)	
MDI operation	
DNC operation	Needed DNC software / CF card
Program restart	
Wrong operation prevention	
Program check function	Dry run
Single block	
Search function	Program Number / Sequence Number
Interpolation functions	
Pano interpolation	
Positioning	G00
Linear interpolation	G01
Circular interpolation	G02, G03
Exact stop mode	Single : G09, Continuous : G61
Dwell	G04, 0 ~ 9999.9999 sec
Skip	G31
Reference position return	1st reference : G28, 2nd reference : G30 Ref. position check : G27
Thread synchronous cutting	G33
Thread cutting retract	
Variable lead thread cutting	
Multi / Continuous threading	
Feed function / Acc. & Dec. control	
Manual feed	Rapid traverse Jog : 0~2,000 mm/min (79 ipm) Manual handle : x1, x10, x100 pulses Reference position return
Cutting Feed command	Direct input F code
Feedrate override	0 ~ 200% (10% Unit)
Rapid traverse override	1%, F25%, 50%, 100%
Override cancel	
Feed per minute	G98
Feed per revolution	G99
Look-ahead block	1 block
Program input	
Tape Code	EIA / ISO
Optional block skip	9 ea
Program stop / end	M00, M01 / M02, M30
Maximum command unit	± 999,999.999 mm (± 99,999.9999 inch)
Plane selection	X-Y : G17 / Z-X : G18 / Y-Z : G19
Workpiece coordinate system	G52, G53, 6 pairs (G54 ~ G59)
Manual absolute	Fixed Off
Programmable data input	G10
Sub program call	10 folds nested
Custom macro	#100 ~ #199, #500 ~ #999
G code system	A, B/C
Programmable mirror image	G51.1, G50.1
G code preventing buffering	G4.1
Direct drawing dimension program	Including Chamfering / Corner R
Conversational Program	Smart Guide-i

Program input	
Multiple repetitive cycles	1, 11
Canned cycle for turning	
Auxiliary function / Spindle speed function	
Auxiliary function	M & 4 digit
Level-up M Code	High speed / Multi / Bypass M code
Spindle speed function	S & 5 digit, Binary output
Spindle override	0% ~ 150% (10% Unit)
Multi position spindle orientation	M19 (S##)
Rigid tapping	
Constant surface speed control	G96, G97
Tool function / Tool compensation	
Tool function	T & 2 digit + Offset 2 digit
Tool life management	
Tool offset pairs	128 pairs
Tool nose radius compensation	G40, G41, G42
Geometry / Wear compensation	
Direct input of offset measured B	
Editing function	
Part program storage size	5,120m (2MB)
No. of registerable programs	1,000 ea
Program protect	
Background editing	
Extended part program editing	Copy, move and change of NC program
Memory card program edit	
Data input / output & Interface	
I/O interface	CF card, USB memory Embedded Ethernet interface
Screen hard copy	
External message	
External key input	
External workpiece number search	
Automatic data backup	
Setting, display and diagnosis	
Self-diagnosis function	
History display & Operation	Alarm & Operator message & Operation
Run hour / Parts count display	
Maintenance information	
Actual cutting feedrate display	
Display of spindle speed / T code	
Graphic display	
Operating monitor screen	Spindle / Servo load etc.
Power consumption monitoring	Spindle & Servo
Spindle / Servo setting screen	
Multi language display	Support 24 languages
Display language switching	Selection of 5 optional Languages
LCD Screen Saver	Screen saver
Unexpected disturbance torque	BST (Back spin torque limit)
Function for machine type	
Cs contour control (C & A axis)	Mill, MS, Y, SY, LF-Mill, TTMS, TTSY
Polar coordinate interpolation	Mill, MS, Y, SY, LF-Mill, TTMS, TTSY
Cylindrical interpolation	Mill, MS, Y, SY, LF-Mill, TTMS, TTSY
Polygon turning (2 Spindles)	Mill, MS, Y, SY, LF-Mill, TTMS, TTSY
Canned cycle for drilling	Mill, MS, Y, SY, LF-Mill, TTMS, TTSY
Spindle orientation expansion	MS, SY TTS, TTMS, TTSY
Spindle synchronous control	MS, SY TTS, TTMS, TTSY
Torque control	MS, SY TTS, TTMS, TTSY
Y axis offset	Y, SY, TTSY
Arbitrary angular control	Y, SY, TTSY
Composite / Superimposed control	MS, SY, TTS, TTMS, TTSY
Balance cutting	TTS, TTMS, TTSY
Option	
Fast ethernet	Needed option board
Data server	Needed option board
Protection of data at 8 levels	
Tool offset pairs	200 pairs
Helical interpolation	
Optional block skip	40 ea, 200 ea (AICC 11)

Figures in inch are converted from metric values.

The FANUC controller specifications are subject to change based on the policy of company CNC supplying.

CONTROLLER

SIEMENS 828D

[] : Option ☆ Needed technical consultation

Controlled axis / Display / Accuracy Compensation

Control axis	2 axis (X, Z) – Std.
	3 axis (X, Z, C) – Mill
	4 axis (X, Z, Y, C) – Y
	5 axis (X, Z, B, C, A) – MS
	6 axis (X, Z, Y, B, C, A) – SY
Simultaneously controlled axis	Max. 4 axis
Least setting Unit	X, Z, Y, B axis : 0.001 mm (0.0001 inch)
	C, A axis : 1 deg [0.001] deg
Least input increment	X, Z, Y, B axis : 0.001 mm (0.0001 inch)
	C, A axis : 1 deg [0.001] deg
Inch / Metric changeover	G70 (inch) / G71 (metric)
Interlock	All axis / Each axis
Backlash compensation	
Pitch error compensation	Leadscrew pitch error compensation
LCD / MDI	15 inch color LCD (With Touch panel)
Keyboard	QWERTY full keyboard
Stored stroke check	Over travel

Operation

Automatic operation	
MDI operation	
Program restart	
Program check function	Dry run / Program check / Machine lock
Single block	
Block search	Block search
Reposition	
Working area limit	Working area limitations

Interpolation functions

Positioning	G00
Linear interpolation	G01
Circular interpolation	Circular interpolation CW (G02)
	Circular interpolation CCW (G03)
Exact position stop	Single block exact stop (G09)
	Exact stop G60 (G601, G602, G603)
Dwell	Dwell (G04)
Reference position return	Return to reference point
	Return to 2nd reference point
Helical interpolation	
Thread synchronous cutting	
Thread cutting retract	
Spline interpolation	Non-uniform rational B splines

Feed function / Acc. & Dec. control

Manual feed	Rapid traverse
	Jog
	Manual handle
	Reference position return
Cutting feed command	Direct input F code
Feedrate override	0 ~ 200% (10% Unit)
Rapid traverse override	1%, 25%, 50%, 100%
Feed per minute	G94
Feed per revolution	G95
Look-ahead block	1 block

Program input

ISO support	G291 (ISO)/G290 (SIEMENS)
	(ISO G Code system-A)
Optional block skip	2
Program stop / end	M00, M01 / M02, M30
Maximum command unit	± 999,999,999 mm, ± 99,999,999 inch
Plane selection	X-Y : G17, X-Z : G18, Y-Z : G19
	G54 ~ G57, G505~G549
Workpiece coordinate system	G500 (Basic frame – setable zero offset)
	G53 (Work offset non modal)
	G153 (basic frame non modal)
Sub program call	11 folds nested
G code preventing buffering	STOPRE
Turning cycle	Turning programing (Cycle 93, 94, 95, 97)
User cycle	
3D simulation	
Real time simulation	
Shop Turn	Machining step programming for turning

Auxiliary function / Spindle speed function

Auxiliary function	M Code 4 digit
Spindle speed function	S Code 5 digit
Spindle override	0% ~ 150% (10% Unit)
Spindle orientation	SPOS
Rigid tapping	
Automatic mode interchange	Spindle / Axis mode
Constant surface speed control	G96, G97
Spindle speed limitation	LIMS

Tool function / Tool compensation

Tool function	Tool number & Tool name
Tool life management	Tool : T + Offset : D
Tools in tool list	128 ea : Std.
	256 ea : Mill
	768 ea : Y, MS, SY
Cutting Edges in tool list	256 ea : Std.
	512 ea : Mill
	1,536 ea : Y, MS, SY
Tool nose radius compensation	ISO (G40, G41, G42)
Geometry / Wear compensation	
Measurement of tool length	
Tool management function	

Editing function

Part program storage size	3MB – Std.
	5MB – Mill
	10MB – Y, MS, SY
No. of registerable programs	750 ea
External Storage devices	Local network, Server, USB, Flash drive
Background editing	
Extended part program editing	Copy, move and change of NC program
Memory card program edit	

Data input / output & Interface

I/O interface	CF card interface (ONLY 10.4")
	USB memory interface
	Embedded Ethernet memory interface
Screenshot	

Setting, display and diagnosis

Self-diagnosis function	
History display & Operation	Alarm & Operator message & Operation
Run hour / Parts count display	
Maintenance information	
Actual cutting feedrate display	
Display of spindle speed / T code	
Graphic display	
Operating monitor screen	Spindle / Servo load etc.
Multi language display	Support 9 languages
	Chinese (Simplified/Traditional), English, French, German, Italian, Korean, Portuguese, Spanish
	[☆ Support 22 languages : Inquiry need]
LCD Screen Saver	Screen saver & Motion sensing

Function for machine type

Cs contour control (C & A axis)	Mill, MS, Y, SY model
Polar coordinate interpolation	Mill, MS, Y, SY model
Cylindrical interpolation	Mill, MS, Y, SY model
Canned cycle for drilling	Mill, MS, Y, SY model
[Polygon turning (CP-Basic)]	Mill, MS, Y, SY model
[Hobbing / Skybing (CP-Comfort)]	Mill, MS, Y, SY model
Spindle synchronous control	MS, SY model
Servo tailstock function	MS, SY model

Option

Additional optional block skip	10
Contour handwheel	

MOVEMENT FOR BETTER TOMORROW



ECO FRIENDLY

Minimizing Environmental Impact and Maintaining Sustainable Ecology

01

**Achieve
carbon
neutrality**

- Develop Net-zero Roadmap
- Heighten carbon emissions management
- Achieve carbon neutrality goals

02

**Boost
resource
circulation**

- Detail plans to reduce environmental impact
- Gradually reduce pollutant emissions
- Build eco-friendly supply chain

03

**Establish
environmental
management
framework**

- Set up environmental management process
- Assess business impact of climate change risks

HYUNDAI WIA ECO SYSTEM

MQL (Minimal Quantity Lubrication)

The goal of this system is to spray only the amount of lubricant required to prevent heat and chip build up at the cutting tool or work piece face.

Example of Turning Center Application

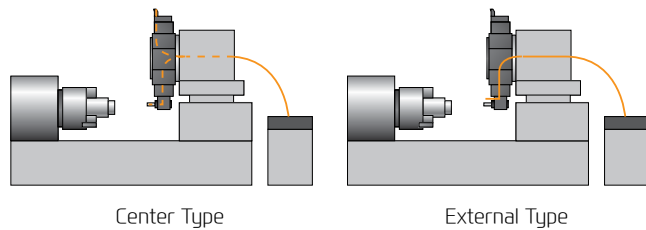

Example of Etc.

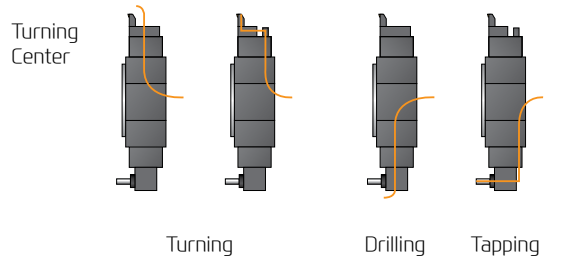

Oil Skimmer

An oil skimmer can increase coolant and tool life by removing tramp oil contaminants.



Mist Collector

Mist Collector reduces the amount of smoke and oil mist in the air. This helps build a safe and comfortable working environment and improve durability.

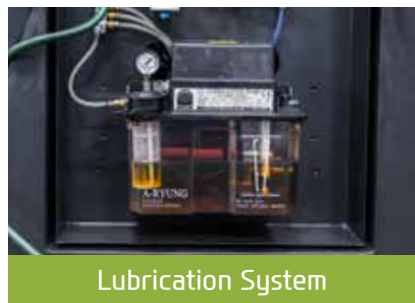

Lubrication System

By applying lubricant only when the machines axis are moving lubrication consumption is reduced by compared to standard systems.

HYUNDAI WIA ENERGY SAVING

HW-ESS (HYUNDAI WIA Energy Saving System)

HYUNDAI WIA Machine tool provides the optimum power saving function that can easily save energy with an intuitive user interface.



1. **Machine-ready power saving function** : Put all servo motors and other motors into sleep mode when no control or operation is done for a set time
2. **Work light auto-off function** : The work light is turned off automatically when no control or operation is done for a set time
3. **Chip conveyor auto power saving** : Operation/non operation time (timer) can be set to save energy
4. **Auto Power-off** : Auto power off after ending the an operation after a period of time
5. **Eco function** : Machine ready sleep mode can be activated/de-activated from the controller panel
6. **Power consumption monitor** : Real time power consumption can be monitored through the OP screen



YouTube HYUNDAI WIA MT
www.youtube.com/HYUNDAIWIAMT

CREATING VALUE IN SEAMLESS MOBILITY

With its top-quality HYUNDAI WIA machine tool creates a new and better world.



<http://machine.hyundai-wia.com>
HYUNDAI WIA Machine Tools
Global Links

HEADQUARTER

R&D Center/Factory 153, Jeongdong-ro, Seongsan-gu, Changwon-si, Gyeongsangnam-do, Korea TEL : +82 55 280 9114 FAX : +82 55 282 9114

Overseas Sales Team /R&D Center 37, Cheoldobangmulgwan-ro, Uiwang-si, Gyeonggi-do, Korea TEL : +82 31 8090 2539

OVERSEAS OFFICES

HYUNDAI WIA Machine America corp. 450 Commerce Blvd, Carlstadt, NJ 07072, USA TEL : +1-201-987-7298

HYUNDAI WIA Europe GmbH Alexander-Fleming-Ring 57, 65428 Rüsselsheim Germany TEL : +49-0-6142-9256-0

HYUNDAI WIA Machine Tools China 2-3F, Bldg6, No.1535 Hongmei Road, Xuhui District, Shanghai, China TEL : +86-21-6427-9885

Russia Branch Office 141006, Russia, Moscow Region, Mytishchi, Volkovskoe sh. 5A, b. 1, office 306 TEL : +7-495-502-7023

India Branch Office #4/169, 1st Floor, LOTTE BLDG, Rajiv Gandhi Salai, (OMR), Kandanchavadi, Chennai - 600096, Tamilnadu, India TEL : +91-76-0490-3348