

# SE 2600 Series

CNC Turning Center for Productivity

HYUNDAI WIA CNC Turning Center

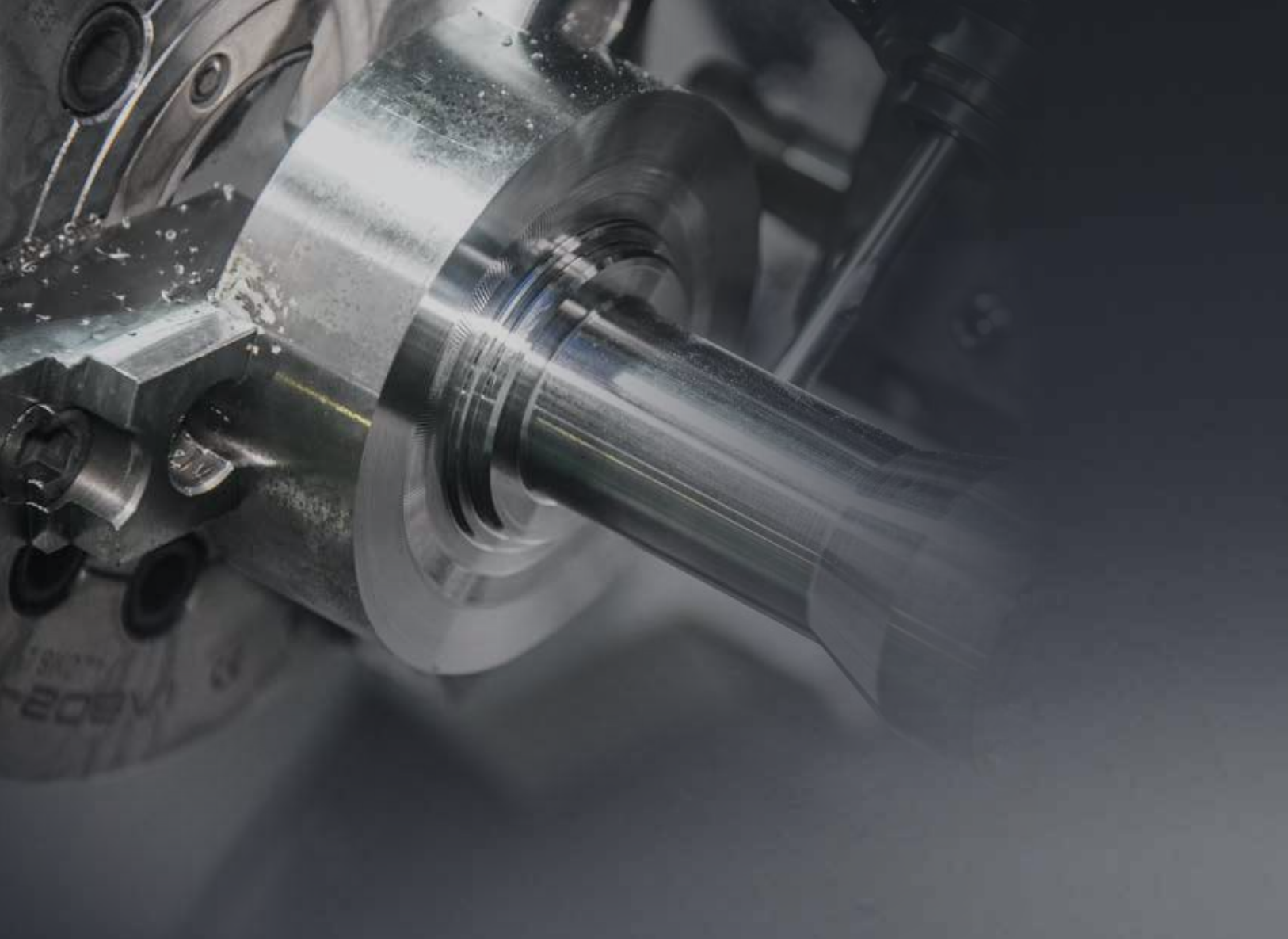

# Technical Leader

The CNC Turning Center SE2600 Series, designed with HYUNDAI WIA's engineering expertise to maximize productivity by enhancing rigidity and accuracy of machining.

ITEM	Main Spindle	Sub Spindle	Bed Type		Turret		Y-Axis
	10"	6"	Std. Bed	Long Bed	Standard	Mill turret	
SE2600	•		•		•		
SE2600L	•			•	•		
SE2600M	•		•			•	
SE2600LM	•			•		•	
SE2600Y	•		•			•	•
SE2600LY	•			•		•	•
SE2600SY	•	•	•			•	•
SE2600LSY	•	•		•		•	•

# SE 2600 Series

High-speed Type CNC Turning Center for Productivity

- 30° slanted one-piece bed structure with high rigidity
- Applying high-rigidity roller type LM guideway on all axis
- Hydraulic NC tailstock with position control (SE2600/M/Y)
- Multi-tasking operation with wedge type Y-axis structure (SE2600Y/SY/LY/LSY)
- Improved user convenience by applying the latest controller of FANUC





HYUNDAI  
**WIA SE 2600SY**



# APPLICATIONS & PARTS

## Reduced machining time by multi-tasking operation

SE2600Y Series with Y-axis makes it possible to work high-valued product with integrated processing using sub spindle and various rotary tools in short time.



WHEEL HUB



DRIVE GEAR



WORM SHAFT

## MACHINING CAPABILITY

HYUNDAI WIA is doing its best to get the world-top class quality, productivity and technology for meeting the global customers' needs through its full R&D investment.

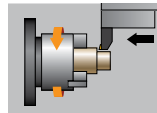

O.D Turning  
(Material : SM45C)

Machining Dia.	Ø92 mm (Ø3.5")
Machining depth	4 mm (0.16")
Spindle rpm	727 r/min
Cutting speed	210 m/min
Forwarding speed	0.55 mm/rev
Chip discharging amount	462 cc/min

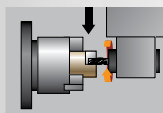

End Mill  
(Material : SM45C)

Tool Dia.	Ø16 mm (Ø0.6")
Spindle rpm	995 r/min
Forwarding speed	150 mm/min
Cutting speed	50 m/min
Machining depth	16 mm (0.6")

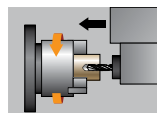

U-Drill  
(Material : SM45C)

Tool Dia.	Ø60 mm (Ø2.4")
Spindle rpm	551 r/min
Forwarding speed	0.33 mm/rew
Cutting speed	104 m/min
Chip discharging amount	512 cc/min

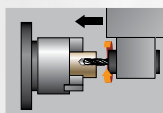

Drill  
(Material : SM45C)

Tool Dia.	Ø14 mm (Ø0.6")
Spindle rpm	1,820 r/min
Forwarding speed	300 mm/min
Cutting speed	80 m/min

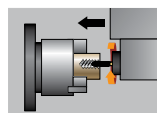

Tap  
(Material : SM45C)

Tap spec.×Pitch	M14×P2.0
Spindle rpm	133 r/min
Forwarding speed	2 mm/min
Cutting speed	5 m/min

❖ The above result might be different by types of processing circumstances.

# 01 SE2600/M/L/LM

The Best Productivity 10" CNC Turning Center

## Turret

- Std. Turret : 10 EA [Opt. 12 EA]
- Mill Turret : BMT55 12 EA [Opt. 24 EA]

## Tail Stock

- MT#4
- Hydraulic PC Tailstock

## Spindle

- Std. : 3,500 r/min
- Opt. : Power Up 2,500 r/min
- C-Axis Control : 0.001°

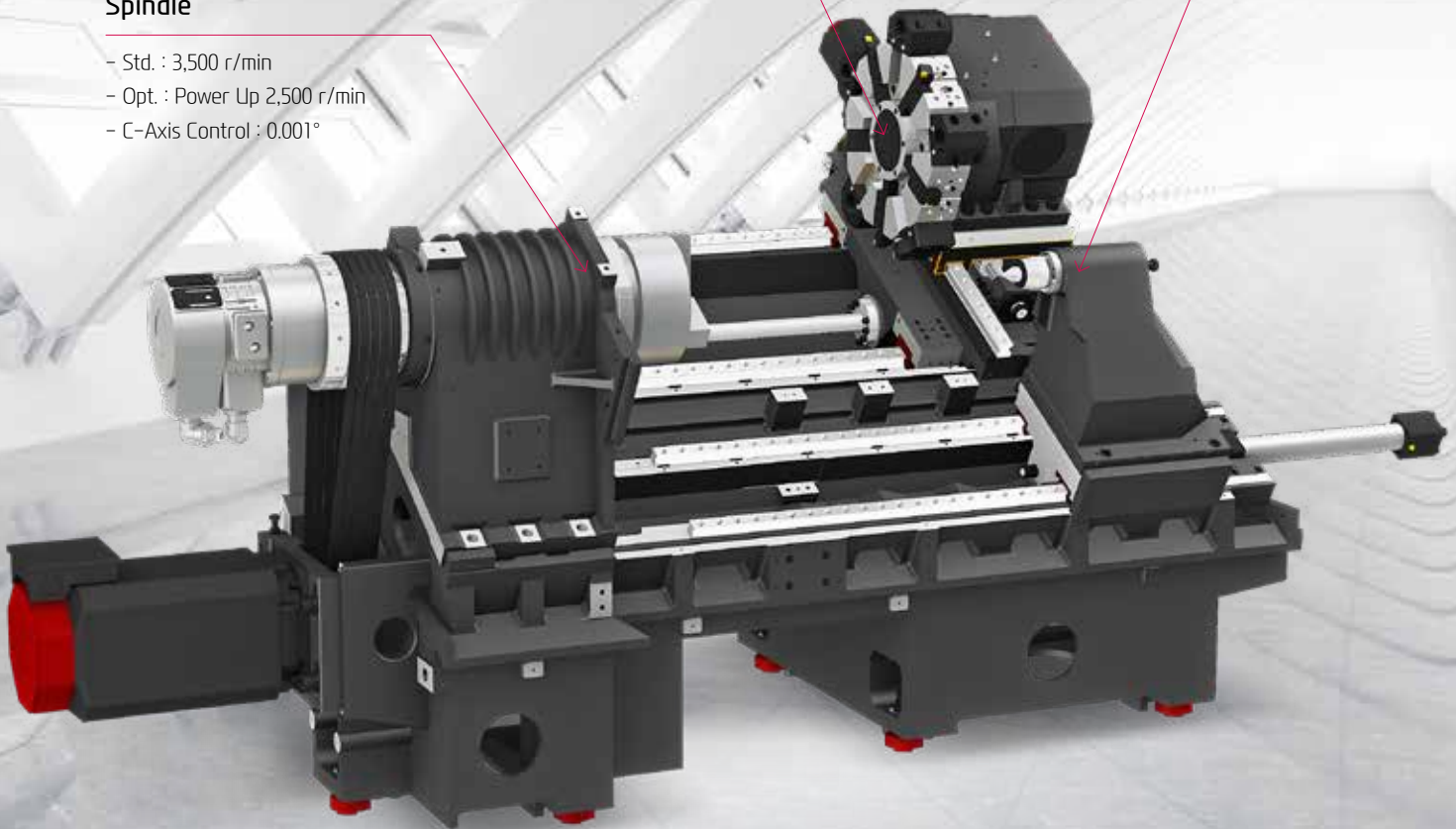

# REDUCTION OF NON-CUTTING TIME BY FAST RAPID SPEED

## 30° SLANTED ONE-PIECE BED

### Optimal Structural Analysis

Structural analysis was applied to the design of the machine to increase the tool post body and reduce the machine's height so as to maintain the bed's dynamic rigidity even during high-speed machining.

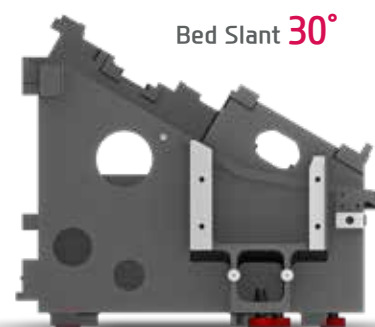

ENHANCED VIBRATION ABSORPTION THANKS TO INCREASED GROUND AREA

## GUIDEWAY

### High-Speed Roller LM Guideway

Linear roller guideways are applied to reduce non-cutting time and bring high rigidity.

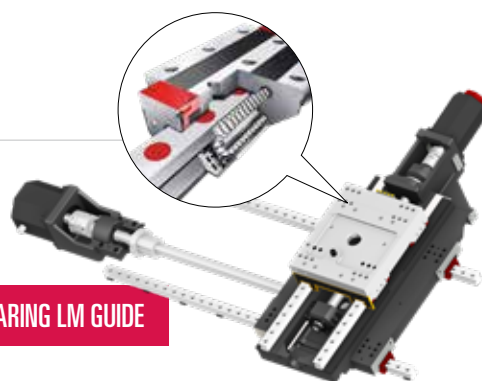

RIGIDITY HAS INCREASED 30% COMPARED TO THE BALL BEARING LM GUIDE

Rapid Traverse Rate  
(X/Z)

**30/30** m/min (1,181/1,181 ipm)

### Ball Screw

Travel is stabilized by fastening both ends of the ball screw using the double anchored method. In particular, a large diameter ball screw with proper preload reinforces sturdiness and resistance to thermal displacement.

#### Travel (X/Z)

SE2600

**265/680** mm (10.4"/26.8")

SE2600L

**265/1,100** mm (10.4"/43.3")

SE2600M

**255/680** mm (10"/26.8")

SE2600LM

**255/1,100** mm (10"/43.3")

# 02 SE2600Y/SY/LY/LSY

Y-axis Structure Design for Machining High Value-added Complex Workpiece

## BMT55 Mill Turret

- Speed : 6,000 r/min
- Max. Power : 5.5 kW
- Max. Torque : 52.5 N.m

## Sub Spindle (SE2600SY)

- Chuck Size : 6"
- Speed : 4,500r/min

## Spindle

- Std. : 3,500 rpm
- Opt. : Power Up 2,500 r/min

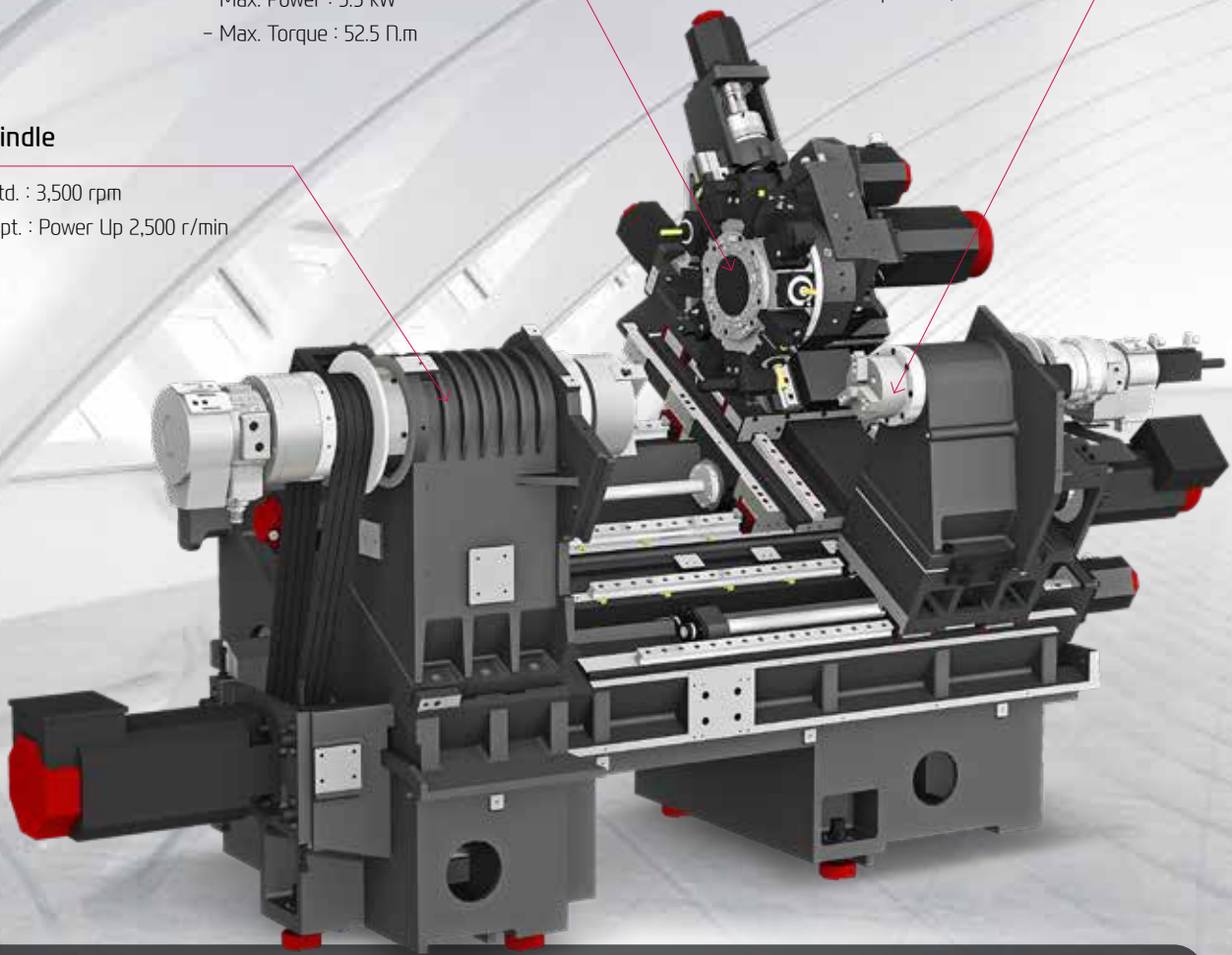

### Travel (X/Y/Z/ZB)

SE2600Y/SY

255/110/680/660 mm

(10"/4.3"/26.8"/26")

SE2600LY/LSY

255/110/1,100/1,080 mm

(10"/4.3"/43.3"/42.5")



# REALIZATION OF COMPLEX MACHINING THROUGH Y-AXIS & SUB-SPINDLE

## COMPLEX MACHINING

### Y-Axis Structure

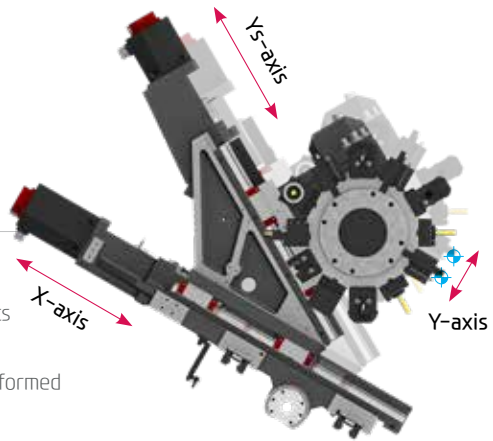
SE2600Y/LY/SY/LSY with Y-axis added can even machine products that cannot be machined on the 2-axis turning centers. Contributes to productivity improvement with machining being performed on a single machine without a separate machining center process.

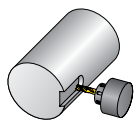
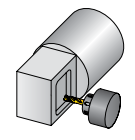
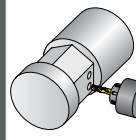
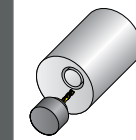
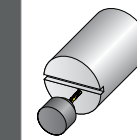

					
Keyway Milling	Multi-sided machining	Eccentric hole machining	X+Y axis circular interpolation	Fine Grooving	

### Sub Spindle (SE2600SY/LSY)

When the main spindle cutting is completed, the sub spindle rotation is synchronized with the main spindle allowing the workpiece to be transferred to the sub spindle, and machining can begin on the back side of the workpiece.

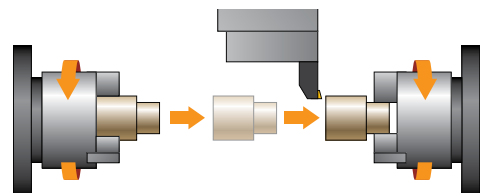

## 30° SLANTED ONE-PIECE BED

By designing the machine bed at 30°, stability has been improved by reducing the height of the machine which previously used a 45° inclined Y-axis CNC turning center.

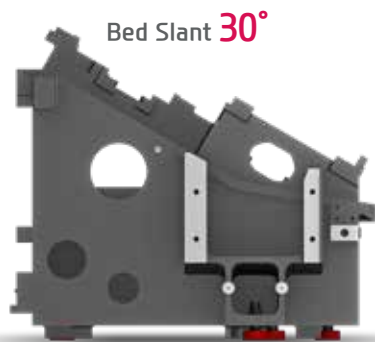

- Height of the machine with the previous 45° inclined Y-axis turning center : 2,225 mm (87.6")
- SE2600SY machine height : 1,960 mm (77.2") - 12% height reduction

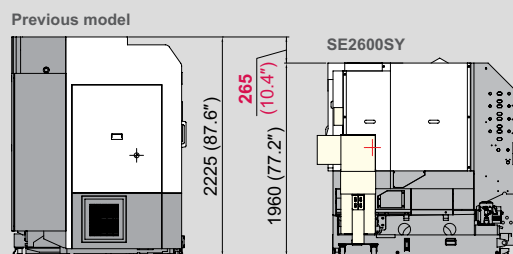

# 03 HIGH PRECISION SPINDLE

High-performance Spindle for Powerful Cutting and Precision

## Spindle Specifications

[ ] : Option

Model	Spindle Speed	Motor (Max./Cont.)	Torque (Max./Cont.)
SE2600/M/L/LM SE2600Y/LY	3,500 rpm	18.5/15 kW (25/20 HP)	470.9/286.4 N·m (347.3/211.2 lbf·ft)
	[2,500 rpm]	[26/18.5 kW (35/25 HP)]	[734/522 N·m (541.4/385 lbf·ft)]
SE2600SY/LSY	Main : 3,500 rpm	18.5/15 kW (25/20 HP)	470.9/286.4 N·m (347.3/211.2 lbf·ft)
	Main : [2,500 rpm]	[26/18.5 kW (35/25 HP)]	[734/522 N·m (541.4/385 lbf·ft)]
	Sub : 4,500 rpm	7.5/5.5 kW (10/7.5 HP)	85/47 N·m (62.7/34.7 lbf·ft)

# HEAVY DUTY CUTTING & HIGH ACCURACY

## MAIN SPINDLE

### Spindle for Heavy Duty Cutting

The main spindle is designed with the same structure as that often found in larger sized machines. The combination of double cylindrical roller bearings and angular contact ball bearings leads to excellent heavy duty cutting performance. Also, machining performance is enhanced by applying **ribstar belt** to minimize noise and belt slipping problems.

The spindle is designed with a labyrinth structure to minimize possible bearing damage from coolant and to improve machining stability.

### C-axis Control for All Models

The SE2600 Series 'M/Y' Type (featuring a mill turret) can control the C-axis by 0.001°, and the SE2600 (featuring a turning turret) can control the C-axis by 0.03°.

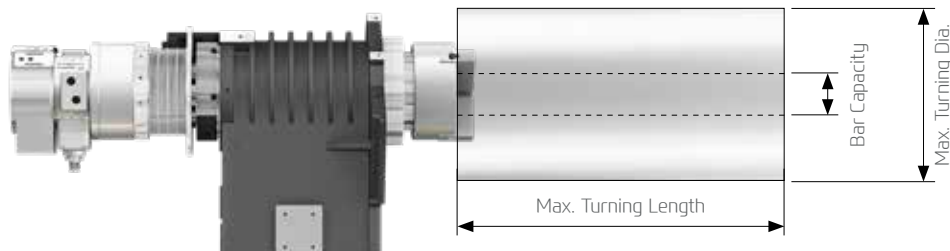

Model	Chuck Size	Max. Turning Length	Max. Turning Dia.	Bar Capacity
SE2600	10 inch	671 mm (26.4")	Ø460 mm (18.1")	Ø81 mm (3.1")
SE2600M		630 mm (24.8")	Ø380 mm (15")	
SE2600Y/SY		653 mm (25.7")	Ø460 mm (18.1")	
SE2600L		1,091 mm (43")	Ø460 mm (18.1")	
SE2600LM		1,050 mm (41.3")	Ø380 mm (15")	
SE2600LY/LSY		1,073 mm (42.2")	Ø380 mm (15")	

## 6 INCH SUB SPINDLE (SE2600SY/LSY)

By applying a high-performance sub-spindles with the maximum output of 7.5kW (10HP) and the maximum torque of 85N.m, powerful cutting performance can be demonstrated even in the secondary process using the sub-spindles.



# 04 SERVO TURRET

Excellent Splitting Accuracy, Strong Tool Clamping

## Standard Turret (SE2600/L)

[ ] : Option

No. of Tools

10 [12]<sub>EA</sub>

Tool Size (O.D./I.D)

□ 25/Ø50 mm (□ 1"/Ø2")

Indexing Time

0.15 sec

## Mill Turret (SE2600M/LM/Y/LY/SY/LSY)

Type	Speed	Motor (Max./Cont)	Torque (Max./Cont)	Collet Size
BMT55	6,000 rpm	5.5/3.7 kW (7.4/5 HP)	52.5/26.5 N·m (38.7/19.5 lbf·ft)	ER25 (Ø16)

Standard : 12-angle 12P (30° rotation) → Optional : 12-angle 24P (15° rotation)

Expanded machining area by increasing the number of tools attached (up to 24 tools)

# VARIOUS DRIVEN PRECISION BMT TOOL HOLDERS

## SERVO TURRET



### Standard Turret (SE2600/L)

The standard turret is applied with high performance AC servo motor, improving machining reliability. 3-piece coupling shows excellent performance in indexing. Powerful hydraulic tool clamping minimizes tool tip deviation caused by load.

### 70Bar High Pressure Coolant **OPTION**

Turret is designed to utilize 70bar high pressure coolant and it shows optimum performance in machining difficult-to-cut material.



## MILL TURRET

### BMT55 Turret (SE2600M/LM/Y/LY/SY/LSY)

The BMT turret secures the tool with four bolts and key on the tool mounting surface of the turret, making it possible to powerfully fix the tool, ensuring high reliability in rigidity and precision.



Triple I.D Holder



Double O.D Holder

### **OPTION**

### 12 Station 24 Position Turret

Efficient tooling is possible by adjusting the partition angle of the turret, which allows a maximum of two external tools per side and three internal tools per side.

ITEM		STd. 12 Station 12 Position	Opt. 12 Station 24 Position
Turret Angle of Rotation		30°	15°
I.D Holder	Single	Ø40 (Ø1 1/2")	Ø40 (Ø1 1/2")
	Double	Ø20 (Ø3/4")	-
	Triple	-	Ø20 (Ø3/4")
O.D Holder	Single	□25 (□1")	□20 (□3/4")
	Double	-	□20 (□3/4")

❖ 24P applicable exclusive to the mill turret

# 05 USER CONVENIENCE

Various Devices for User Friendly

## HYDRAULIC NC TAILSTOCK

### Optimal tail stock line-up for each machine's characteristic

SE2600 series consist of optimized tail stock line-up considering machine's characteristic.

SE2600/M/Y with a standard bed adopts a hydraulic NC tailstock as standard to improve user convenience.

Also, SE2600L/LM/LY with a long bed adopts a hydraulic quill-type tailstock as standard for strong support of long workpiece.

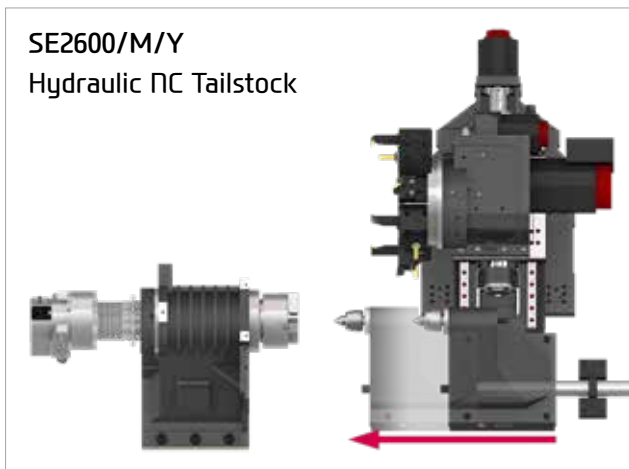

- > Structure in which the tailstock moves independently from the turret (Position control : 0.1mm)
- > Stabilization of tailstock body hydraulic pressure
- > Turret moves independently while the tailstock moves to reduce machining setup time
- > MT#4 live center standard application

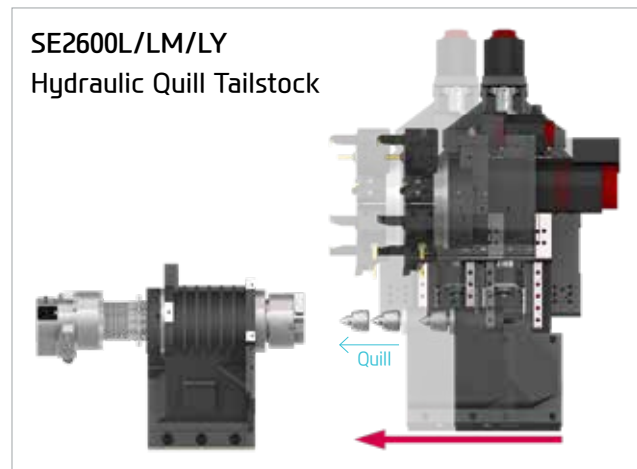

- > A structure that moves by fixing the tailstock to the saddle
- > After fixing the tailstock, the quill operated by hydraulic pressure advances to stabilize the material
- > High rigidity tail spindle and enhancement in thrust
- > Suitable for workpieces subject to vibration during machining and heavy machining load



### HW-TMS (TAILSTOCK OPERATION)

This software is capable of manipulation and data management of tailstock operations through intuitive GUI.

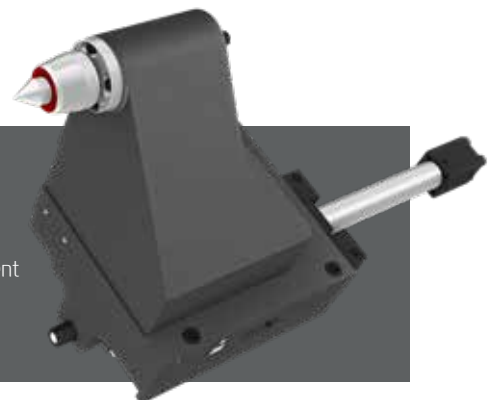

# CHIP DISPOSAL SOLUTION



## Separation Type Coolant Tank

The user convenience has been significantly improved by the separation type coolant tank without having to separate the chip conveyor .

Hinge	Chip Type : Roughing Chip, Long Chip, Chip complex	Material : SS41, 45C, Cast Steel	Front-Right Direction
	Highly efficient when disposing a lot of chips. Capable of handling stringy chips..		
Scraper	Chip Type : Finely broken chip blown out	Material : cast Iron, Nonferrous	
	Convenient for shortly cut chips.		
❖ Drum Filter	Chip Type : Powder, Micro Chip	Material : AL	
	Advantageous in precision, as the chips do not flow in to the coolant nozzle.		

❖ When ordering a drum filter chip conveyor, prior consult with hyundai wia's sales person.

# HIGH PRECISION SYSTEM & COOLANT UNIT OPTION



Q-Setter (Automatic/Manual)



Linear Scale



Gun Coolant



High Pressure Coolant



Chuck Coolant (Upper Chuck)



Chuck Air Blow (Upper Chuck)

# 06 HYUNDAI WIA FANUC – Smart Plus

The Compatible All-round Control



15" Touch-type Monitor as a standard

Fast Cycle Time Technology	Smart Machine Control	Fine Surface Technology
Smart Servo Control Technology	Conversational Program	SmartGuide-i
Machining-aid Function	i-HMI	5120M (2MB)
Part Program Storage	No. of Registerable Programs	1000 EA

## Servo Learning Oscillation Function for Chip Breaking **OPTION**

- Machining Method : he tool cuts the workpiece moving in a zigzag pattern. (Oscillating) → Air cut section occurs → Long chips break
- Advantage : Increase tool life, Enhance surface finishing, Improve chip disposal
- Machine : All turning centers with FANUC controller (Option)

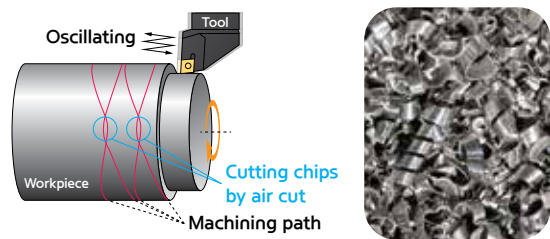

(Developed special screen page for servo learning oscillation function / Even when this function is applied, the cycle time remains same.)

## MMS (Machine Monitoring System)



Manufacturing big data solution with design, manufacturing, and intelligence technology of HYUNDAI-WIA  
(Big data collection/Analysis/Visualization)



### 1. MMS Cloud

A cloud server-based equipment monitoring system for collecting and analyzing facility operation data.

### 2. MMS Edge

A client server-based tool monitoring system for collection/analysis of facility operation data. (Compatible with client MES / ERP interface)

## SMART CNC (FANUC Smart Plus)



### 1. Dialogue Program (Smart Guide-i)

This software offers the maximum user convenience through dialogue manipulation from setup to processing. This includes writing processing programs and simulation checks.

### 2. LAUNCHER

This software offers shortcuts for quick access to specialized features and frequently used features.

# SPECIFICATIONS

## Standard & Optional

● : Standard ○ : Option ☆ : Prior Consultation - : Non Applicable

Spindle		SE2600/L	SE2600/LM
Main Sp. Hollow Chuck 3 Jaw	10"	●	●
	12"	○	○
Main Sp. Solid Chuck 3 Jaw	10"	○	○
	12"	-	-
Standard Soft Jaw (1set)		●	●
Chuck Clamp Foot Switch		●	●
2 Steps Hyd. Pressure Device		○	○
Spindle Inside Stopper		☆	☆
Cs-Axis		● (0.03°)	● (0.001°)
Chuck Open/Close Confirmation Device		●	●
2 Steps Chuck Foot Switch		○	○
Turret			
Tool Holder		●	●
Mill Turret	BMT55	-	●
	12 Station 12P	-	●
	12 Station 24P	-	○
Straight Milling Head	Collet Type, 2ea	-	●
Angular Milling Head	Collet Type, 2ea	-	●
Straight Milling Head	Adapter Type	-	○
Angular Milling Head	Adapter Type	-	○
Boring Sleeve		●	●
Drill Socket		○	○
U-Drill Holder		●	●
U-Drill CAP		●	●
Angle Head		-	☆
Tail Stock & Steady Rest			
Hydraulic NC Tail Stock (Std. Live Center)		●/-	●/-
Quill Type Tail Stock	Manual	○/●	○/●
	Programmable	○	○
	MT4 Live	○/●	○/●
	MT5 Live	○	○
MT4 Built-in		○	○
High Precision Live Center		☆	☆
2 Steps Tail Stock Pressure System		-	-
Quill Forward/Reverse Confirmation Device		○	○
Tail Stock Foot Switch		○	○
Coolant & Air Blow			
Standard Coolant (Nozzle)		●	●
Chuck Coolant (Upper Chuck)		○	○
Gun Coolant		○	○
Through Spindle Coolant (Only for Special Chuck)		☆	☆
Chuck Air Blow (Upper Chuck)		-	-
Sub Chuck Air Blow		○	○
Turnmill Through Coolant		-	○
Tail Stock Air Blow (Upper Tail Stock)		○	○
Turret Air Blow		☆	☆
Air Gun		○	○
Through Spindle Air Blow (Only for Special Chuck)		-	-
High Pressure Coolant	0.5Bar	●	●
	6Bar	○	○
	20Bar	○	○
	70Bar	○	○
Power Coolant System (For Automation)		☆	☆
Coolant Chiller (When selecting Sub Tank Type, Chip Conveyor)		-	-
Chip Disposal			
Coolant Tank	Front(200 ℓ [52.8 gal])	●/-	●/-
	Front(230 ℓ [60.8 gal])	-/●	-/●
	Front(170 ℓ [44.9 gal])	○	○
Chip Conveyor (Hinge/Scrapper)	Front (Right)	○	○
	Rear (Rear)	○	○
Special Chip Conveyor (Drum Filter)		-	-
Chip Wagon	Standard (180 ℓ [47.5 gal])	○	○
	Swing (200 ℓ [52.8 gal])	○	○
	Large Size (330 ℓ [87.2 gal])	○	○
	Customized	☆	☆

Electric Device		SE2600/L	SE2600/LM
Call Light	1Color : ●	●	●
Call Light & Buzzer	3Color : ● ● ● B	○	○
Electric Cabinet Light		○	○
Remote MPG		○	○
Work Counter	Digital	○	○
Total Counter	Digital	○	○
Tool Counter	Digital	○	○
Multi Tool Counter	6ea	○	○
	9ea	○	○
Electric Circuit Breaker		○	○
AVR (Auto Voltage Regulator)		☆	☆
Transformer	25kVA	○	○
Measurement		○	○
Q-Setter		○	○
Automatic Q-Setter		○	○
Work Close Confirmation Device (Only for Special Chuck)	TACO SMC	○	○
Work Setter		☆	☆
Linear Scale	X axis	○	○
	Z axis	○	○
Coolant Level Sensor (Only for Chip Conveyor)		☆	☆
Environment			
Air Conditioner		○	○
Dehumidifier		○	○
Oil Mist Collector		☆	☆
Oil Skimmer (Only for Chip Conveyor)		○	○
MQL (Minimal Quantity Lubrication)		☆	☆
Fixture & Automation			
Auto Door	High-speed	○	○
Auto Shutter (Only for Automatic System)		○/-	○/-
Sub Operation Pannel		☆	☆
Bar Feeder Interface		○	○
Bar Feeder (FEDEK)		☆	☆
Extra M-Code 4ea		○	○
Automation Interface		☆	☆
I/O Extension (IN & OUT)	16 Contact	○	○
	32 Contact	○	○
Parts Catcher		○	○
Turret Work Pusher (For Automation)		☆	☆
Parts Conveyor (Required Main Parts Catcher)		○	○
Semi Automation System		☆	☆
Hyd. Device			
Standard Hyd. Cylinder	Hollow	●	●
Standard Hyd. Unit	35bar/20 ℓ (5.3gal)	●	●
S/W			
Dialogue Program (HW-DPRO)		○	○
DNC software (HW-eDNC)		○	○
Machine Monitoring System (HW-MMS Cloud)		☆	☆
Machine Monitoring System (Customer Installation : HW-MMS Edge)		☆	☆
SmartGuide-i : FANUC		●	●
Smart S/W		☆	☆
Safety Device			
Front Door Interlock		●	●
Total Splash Guard		●	●
Back Spin Torque Limiter (BST)		●	●
Chuck Hydraulic Pressure Maintenance Interlock		☆	☆
ETC			
Tool Box		●	●
Customized Color	Need Munsell No.	☆	☆
CAD & CAM		☆	☆

❖ Thermal Displacement Compensation device is recommended, when more than 6 bar of high pressure coolant is applied, for the high quality machining.

Specifications are subject to change without notice for improvement. / Please refer to the S/W catalog (IRIS) for details by S/W product.

# SPECIFICATIONS

## Standard & Optional

● : Standard ○ : Option ☆ : Prior Consultation - : Non Applicable

Spindle		SE2600Y/LY	SE2600SY/LSY
Main Sp. Hollow Chuck 3 Jaw	10"	●	●
Main Sp. Solid Chuck 3 Jaw	10"	○	○
Sub Sp. Hollow Chuck 3 Jaw	6"	-	●
Sub Sp. Solid Chuck 3 Jaw	6"	-	○
Standard Soft Jaw (1set)		●	●
Chuck Clamp Foot Switch		●	●
2 Steps Hyd. Pressure Device		○	○
Spindle Inside Stopper		☆	☆
Cs-Axis (0.001")	Main	●	●
	Sub	-	●
Chuck Open/Close Confirmation Device		●	●
2 Steps Chuck Foot Switch		○	○
Sub Sp. Foot Switch		-	●
<b>Turret</b>			
Tool Holder		●	●
Mill Turret	BMT55	●	●
	12 Station 12P	●	●
	12 Station 24P	○	○
Straight Milling Head	Collet Type, 2ea	●	●
Angular Milling Head	Collet Type, 2ea	●	●
Straight Milling Head	Adapter Type	○	○
Angular Milling Head	Adapter Type	○	○
Boring Sleeve		●	●
Drill Socket		○	○
U-Drill Holder		●	●
U-Drill CAP		●	●
Angle Head		☆	☆
Adapter Set		○	○
<b>Tail Stock &amp; Steady Rest</b>			
Hydraulic NC Tail Stock (Std. Live Center)		●/-	-
Quill Type Tail Stock	Manual	○/●	-
	Programmable	○	-
	MT4 Live	○/●	-
	MT5 Live	○	-
	MT4 Built-in	○	-
High Precision Live Center		☆	-
2 Steps Tail Stock Pressure System		-	-
Quill Forward/Reverse Confirmation Device		○	-
Tail Stock Foot Switch		○	-
<b>Coolant &amp; Air Blow</b>			
Standard Coolant (Nozzle)		●	●
Chuck Coolant (Upper Chuck)		○	○
Gun Coolant		○	○
Through Spindle Coolant (Only for Special Chuck)		☆	☆
Bed Flushing (Only for Rear Coolant Tank)		○	○
Turnmill Through Coolant		○	○
Chuck Air Blow (Upper Chuck)		○	○
Sub Chuck Air Blow		-	○
Tail Stock Air Blow (Upper Tail Stock)		○	-
Turret Air Blow		☆	☆
Air Gun		○	○
Through Spindle Air Blow (Only for Special Chuck)		-	-
High Pressure Coolant	05Bar	●	●
	6Bar	○	○
	20Bar	○	○
	70Bar	○	○
Power Coolant System (For Automation)		☆	☆
Coolant Chiller (When selecting Sub Tank Type, Chip Conveyor)		-	-
<b>Chip Disposal</b>			
Coolant Tank	Front(200 ℓ [52.8 gal])	●/-	●/-
	Front(230 ℓ [60.8 gal])	-/●	-/●
	Front(170 ℓ [44.9 gal])	○	○
Chip Conveyor (Hinge/Scraper)	Front (Right)	○	○
	Rear (Rear)	○	○
Special Chip Conveyor (Drum Filter)		-	-
Chip Wagon	Standard (180 ℓ [47.5 gal])	○	○
	Swing (200 ℓ [52.8 gal])	○	○
	Large Size (330 ℓ [87.2 gal])	○	○
	Customized	☆	☆

Electric Device		SE2600Y/LY	SE2600SY/LSY
Call Light	1Color : ●	●	●
Call Light & Buzzer	3Color : ●●●B	○	○
Electric Cabinet Light		○	○
Remote MPG		○	○
Work Counter	Digital	○	○
Total Counter	Digital	○	○
Tool Counter	Digital	○	○
Multi Tool Counter	6ea	○	○
	9ea	○	○
Electric Circuit Breaker		○	○
AVR (Auto Voltage Regulator)		☆	☆
Transformer	30KVA	○	○
<b>Measurement</b>			
Q-Setter		○	○
Automatic Q-Setter		○	○
Work Close Confirmation Device (Only for Special Chuck)	TACO SMC	○	○
Work Setter		☆	☆
Linear Scale	X/Y/Z axis	○	○
Coolant Level Sensor (Only for Chip Conveyor)		☆	☆
<b>Environment</b>			
Air Conditioner		○	○
Dehumidifier		○	○
Oil Mist Collector		☆	☆
Oil Skimmer (Only for Chip Conveyor)		○	○
MQL (Minimal Quantity Lubrication)		☆	☆
<b>Fixture &amp; Automation</b>			
Auto Door	High-speed	○	○
Auto Shutter (Only for Automatic System)		○/-	○/-
Sub Operation Panel		☆	☆
Bar Feeder Interface		○	○
Bar Feeder (FEDEK)		☆	☆
Sub Sp. Work Pusher (Spring Type)		-	○
Sub Sp. Work Ejector (Pneumatic Type)		-	○
Extra M-Code 4ea		○	○
Automation Interface		☆	☆
I/O Extension (IN & OUT)	16 Contact	○	○
	32 Contact	○	○
Parts Catcher	Main	○	○
	Sub	-	○
Turret Work Pusher (For Automation)		☆	☆
Parts Conveyor (Required Main Parts Catcher)		○	○
Semi Automation System		☆	☆
<b>Hyd. Device</b>			
Standard Hyd. Cylinder	Hollow	●	●
Standard Hyd. Unit	35bar/20 ℓ (5.3gal)	●	●
<b>S/W</b>			
Dialogue Program (HW-DPRO)		○	○
DFIC software (HW-eDFIC)		○	○
Machine Monitoring System (HW-MMS Cloud)		☆	☆
Machine Monitoring System (Customer Installation : HW-MMS Edge)		☆	☆
SmartGuide-i : FANUC		●	●
Smart S/W		☆	☆
<b>Safety Device</b>			
Front Door Interlock		●	●
Total Splash Guard		●	●
Back Spin Torque Limiter (BST)		●	●
Chuck Hydraulic Pressure Maintenance Interlock		☆	☆
<b>ETC</b>			
Tool Box		●	●
Customized Color	Need Munsell No.	☆	☆
CAD & CAM		☆	☆

❖ Thermal Displacement Compensation device is recommended, when more than 6 bar of high pressure coolant is applied, for the high quality machining.

Specifications are subject to change without notice for improvement. / Please refer to the S/W catalog (IRIS) for details by S/W product.

# SPECIFICATIONS

## Spindle Output/Torque Diagram

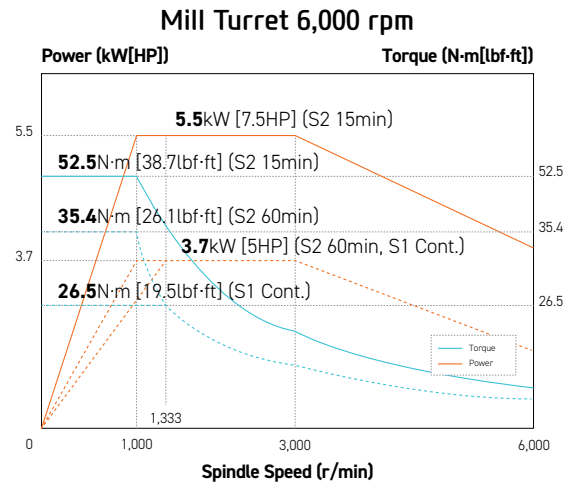
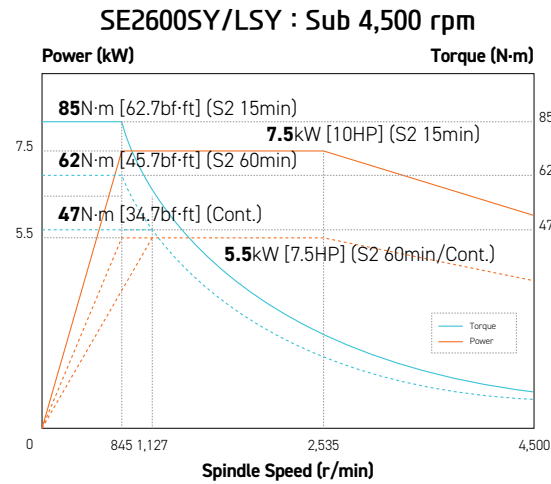
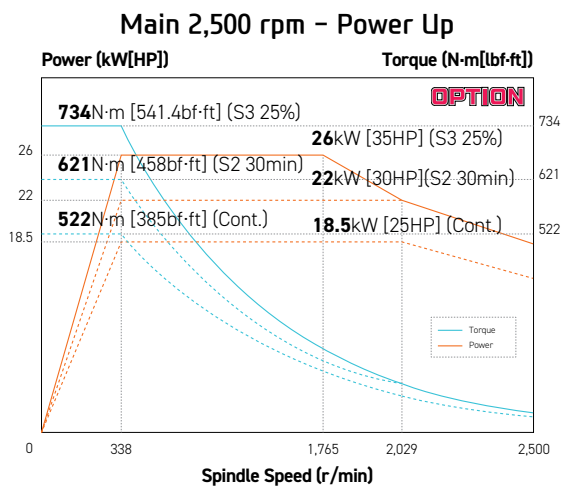
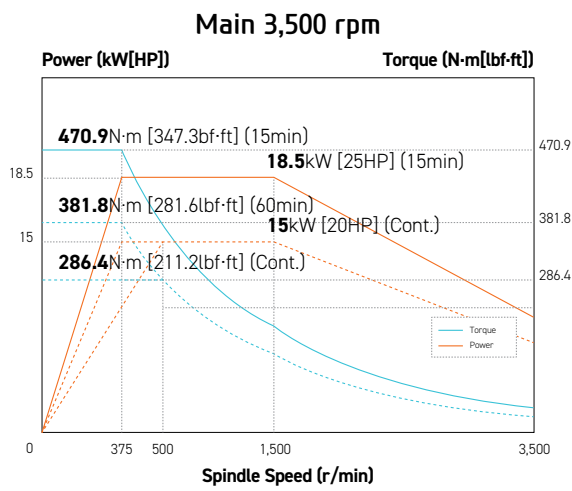

# SPECIFICATIONS

## External Dimensions

unit : mm(in)

SE2600  
SE2600M

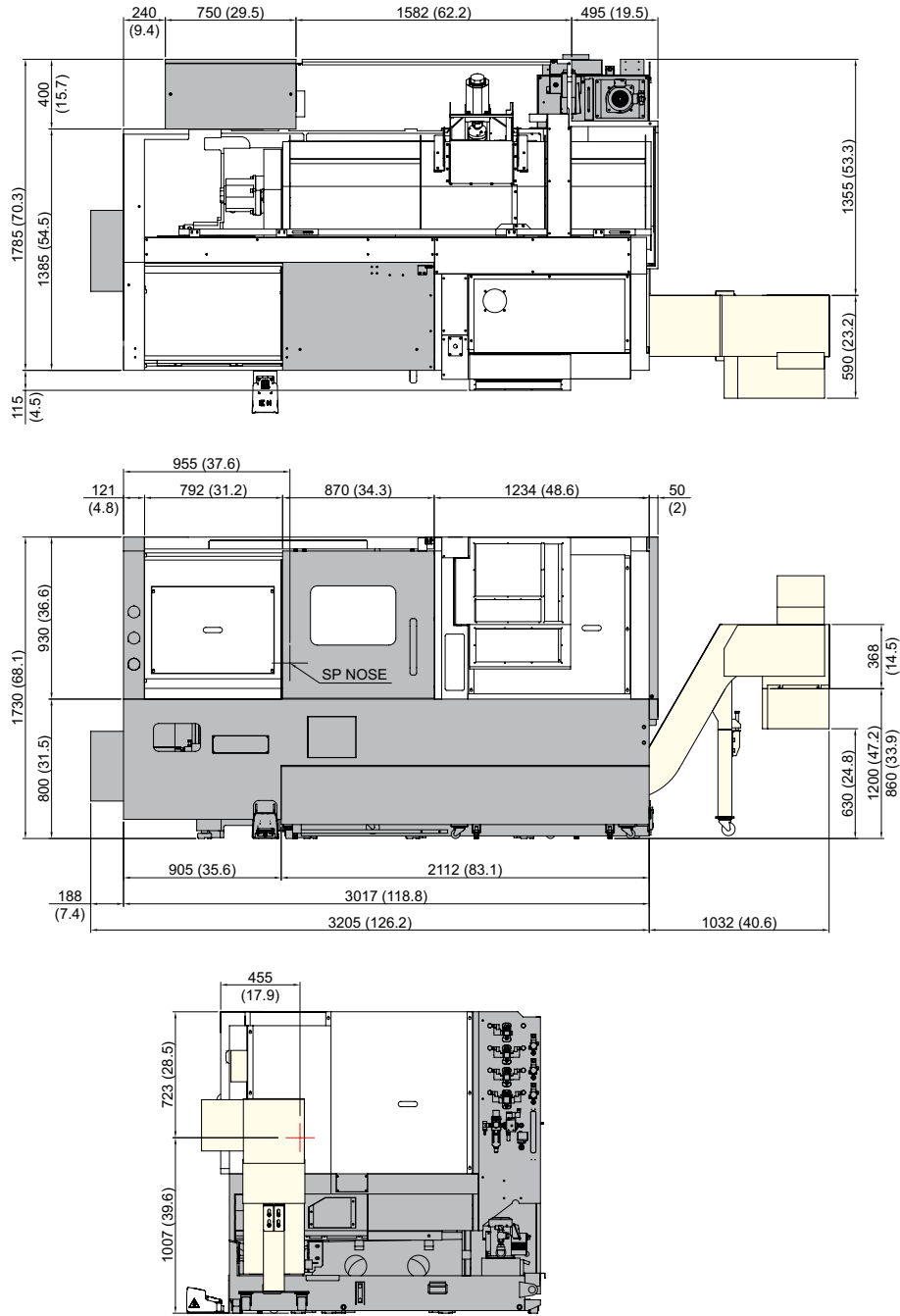

# SPECIFICATIONS

## External Dimensions

unit : mm(in)

SE2600L  
S2600LM

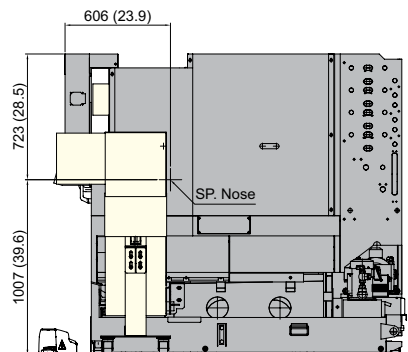
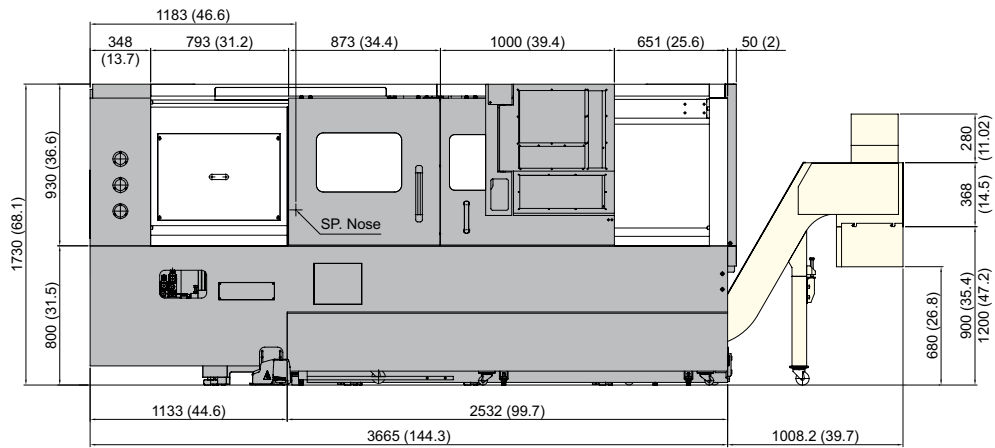
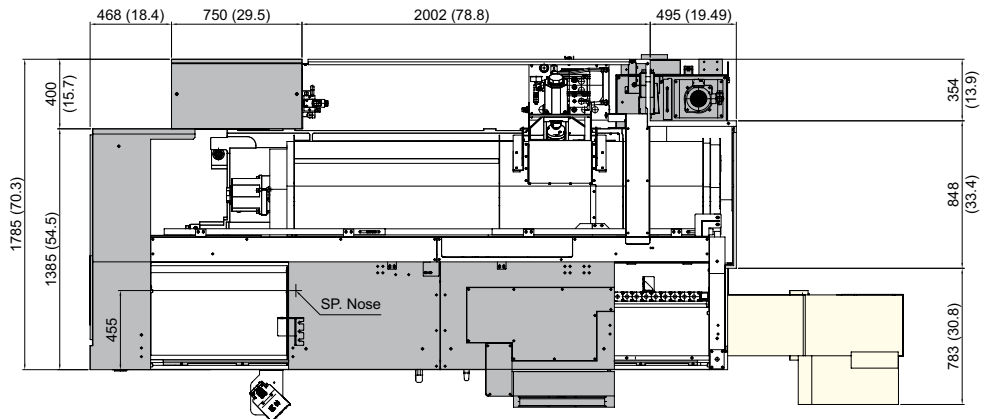

# SPECIFICATIONS

## External Dimensions

unit : mm(in)

SE2600Y  
SE2600SY

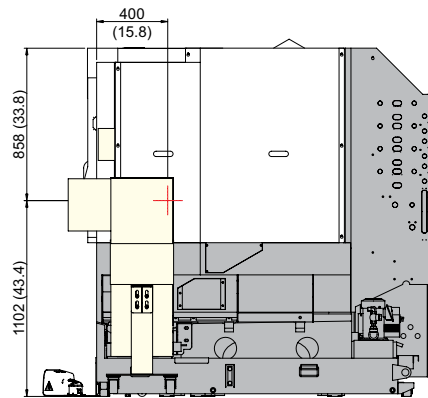
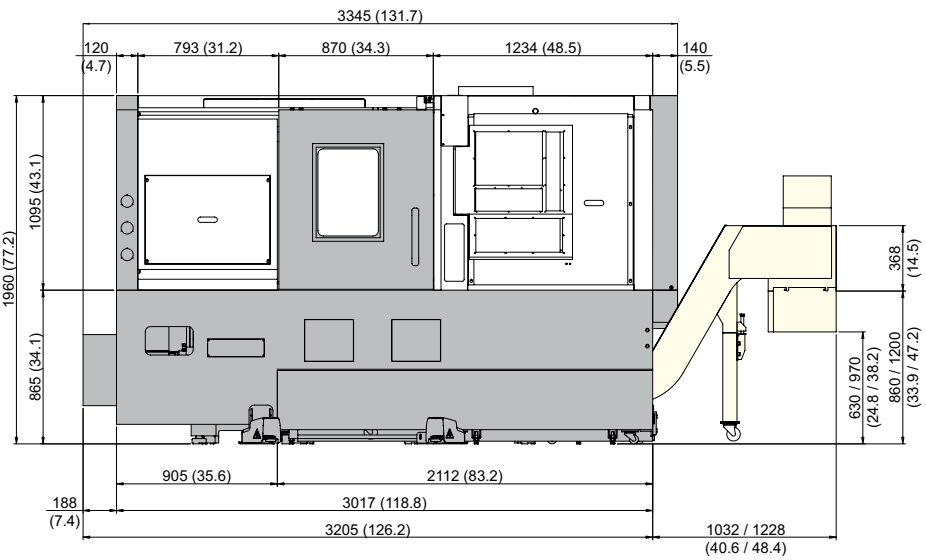
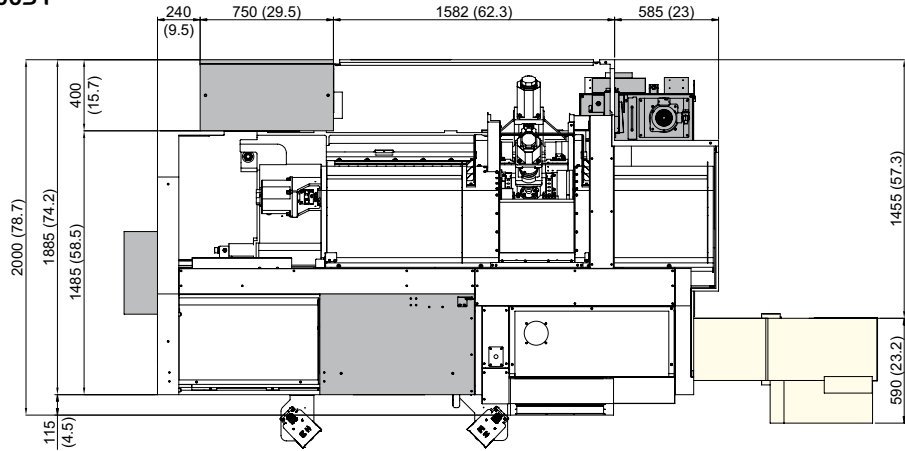

# SPECIFICATIONS

## External Dimensions

unit : mm(in)

SE2600LY  
SE2600LSY

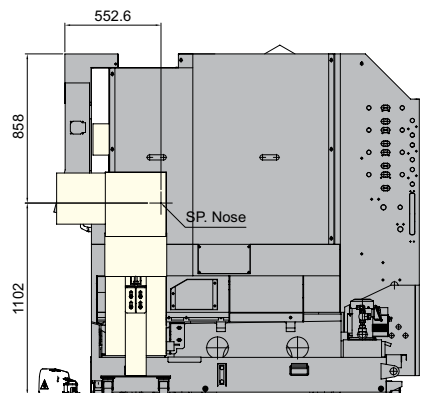
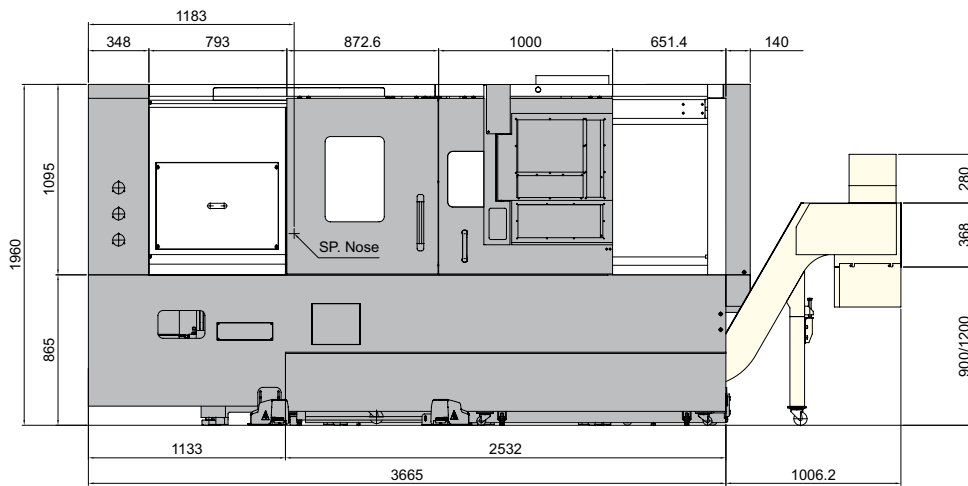
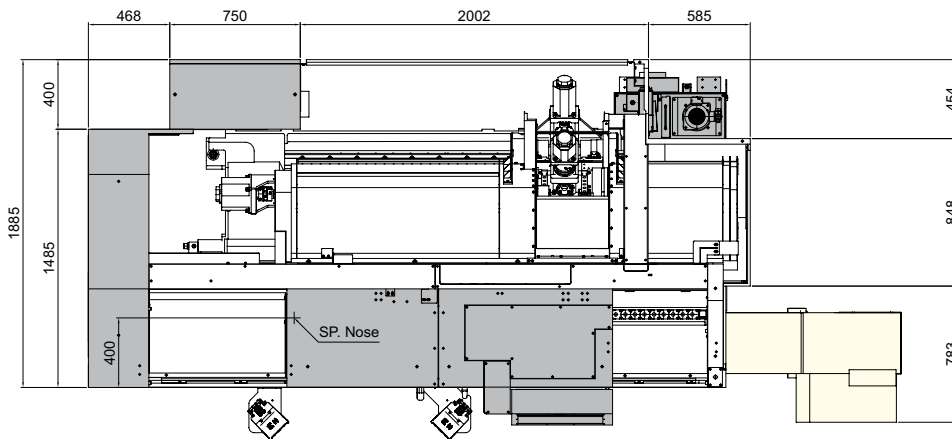

# SPECIFICATIONS

## Interference

unit : mm(in)

SE2600  
SE2600L

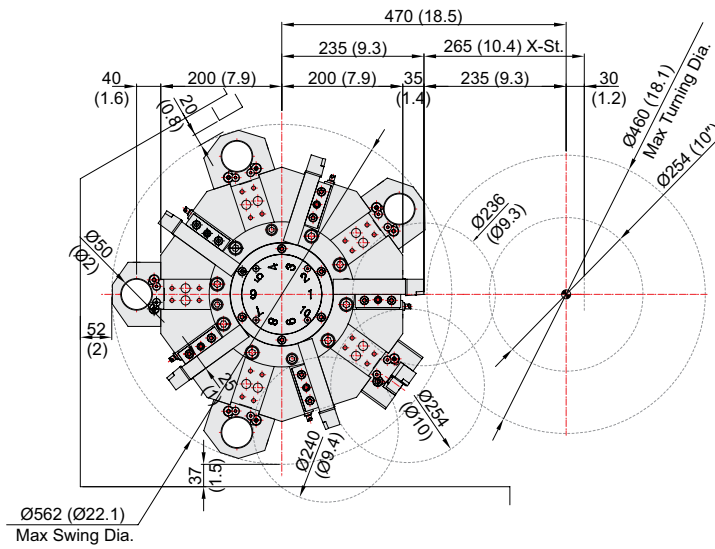

SE2600M  
SE2600LM

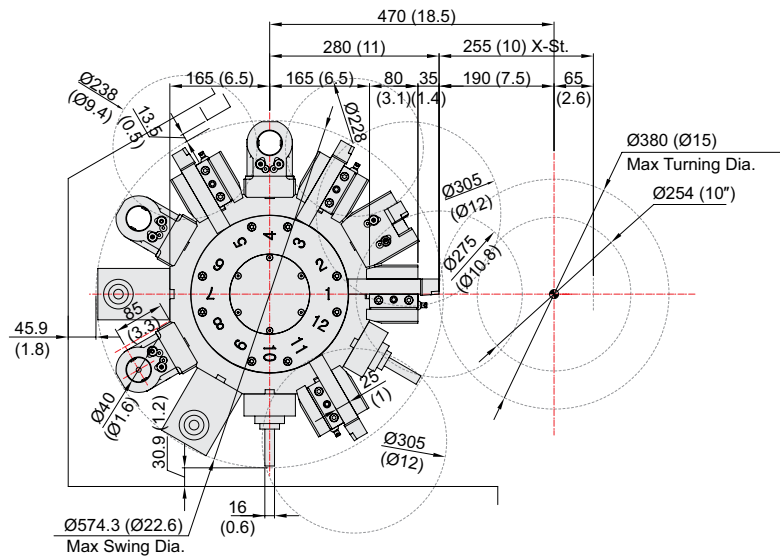

# SPECIFICATIONS

## Interference

unit : mm(in)

SE2600Y  
SE2600LY

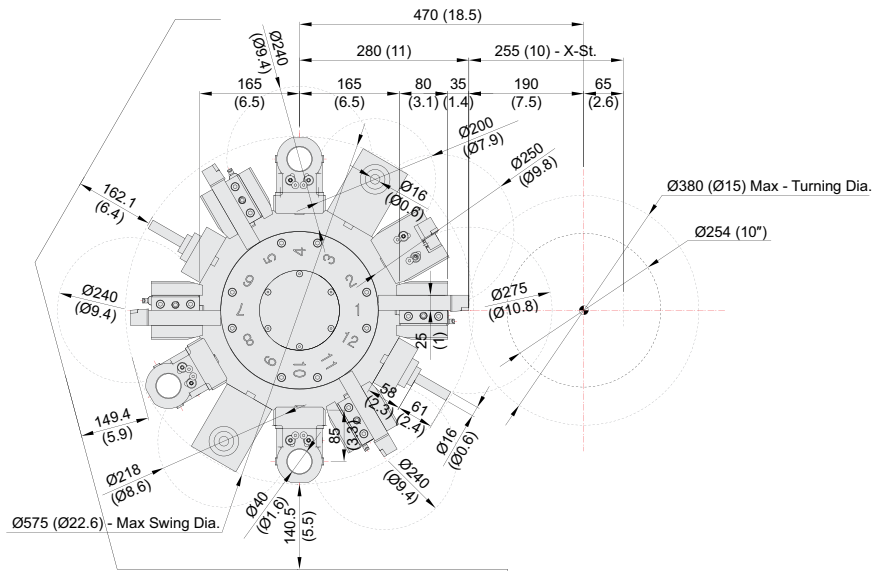

SE2600SY  
SE2600LSY

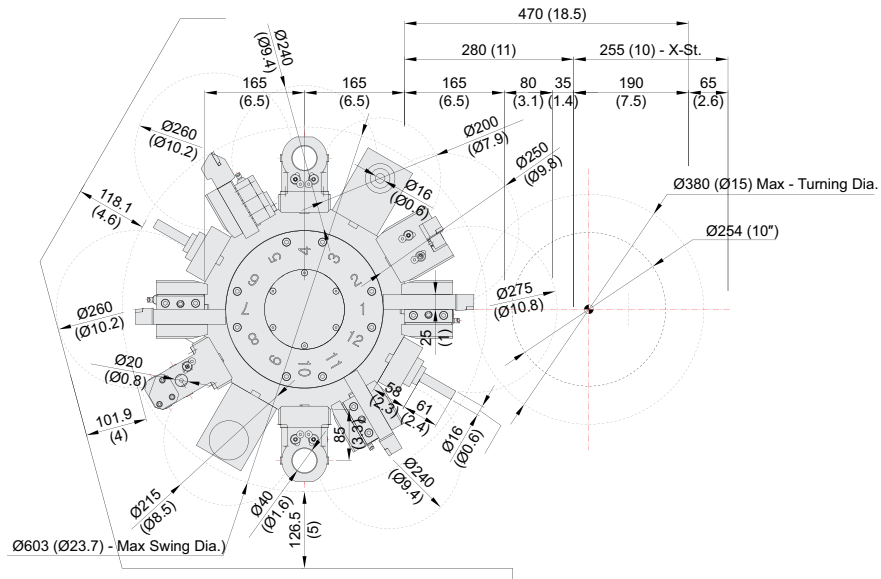

### Angular Milling Y-St.

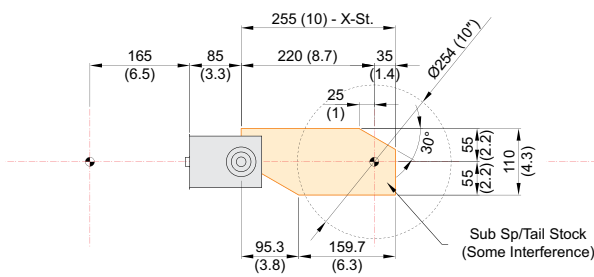

### Straight Milling Y-St.

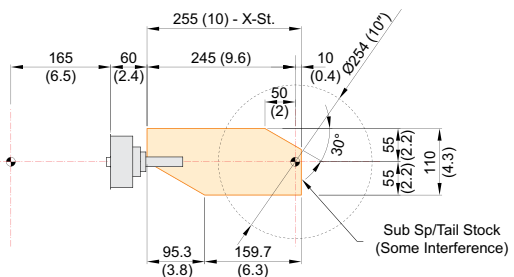

# SPECIFICATIONS

## Tooling System

unit : mm(in)

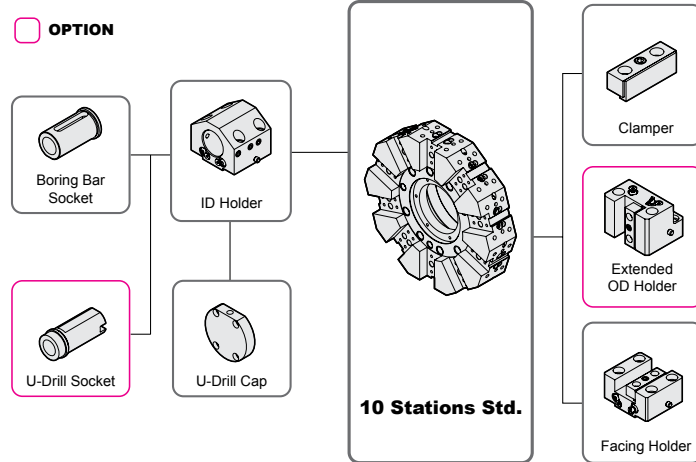

### SE2600/L - Tooling Parts Detail

ITEM			10 Position		12 Position : Opt.	
			mm Unit	inch Unit	mm Unit	inch Unit
Turning Holder	Clamper		5	5	5	5
	O.D Holder	Extension	Opt.	Opt.	1	1
	Facing Holder		1	1	1	1
Boring Holder	I.D Holder	Single	4	4	5	5
	U-Drill	Cap	1	1	1	1
Driven Holder	Straight Mill Holder	Standard	-	-	-	-
		TTC	-	-	-	-
	Angular Mill Holder	Standard	-	-	-	-
		TTC	-	-	-	-
Socket	Boring	Ø12 (Ø1/2")	1	1	1	1
		Ø16 (Ø5/8")	1	1	1	1
		Ø20 (Ø3/4")	1	1	1	1
		Ø25 (Ø1")	1	1	1	1
		Ø32 (Ø1 1/4")	1	1	1	1
		Ø40 (Ø1 1/2")	1	1	1	1
	Drill	MT 1 x MT 2	Opt.	Opt.	Opt.	Opt.
		MT 2	Opt.	Opt.	Opt.	Opt.
		MT 3	Opt.	Opt.	Opt.	Opt.
		MT 4	Opt.	Opt.	Opt.	Opt.
ER Collet		-	-	-	-	

Specifications are subject to change without notice for improvement.

# SPECIFICATIONS

## Tooling System

unit : mm(in)

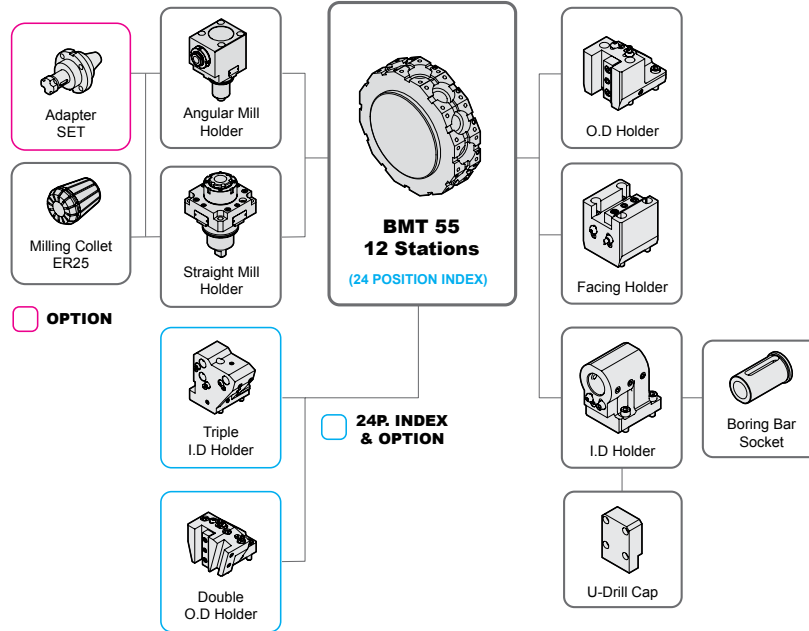

## SE2600M/LM | SE2600Y/LY – Tooling Parts Detail

ITEM			10 Position		12 Position : Opt.	
			mm Unit	inch Unit	mm Unit	inch Unit
Turning Holder	O.D Holder	Right/Left	4	4	3	3
		Double	-	-	1	1
	Facing Holder		1	1	1	1
	Cutting Holder		-	-	-	-
Boring Holder	I.D Holder	Single	3	3	2	2
		Double	-	-	-	-
		Triple	-	-	1	1
	U-Drill Holder	Cap	1	1	1	1
Driven Holder	Straight Mill Holder	Standard	2	2	2	2
	Angular Mill Holder	Standard	2	2	2	2
Socket	Boring	Ø10 (Ø3/8")	1	1	1	1
		Ø12 (Ø1/2")	1	1	1	1
		Ø16 (Ø5/8")	1	1	1	1
		Ø20 (Ø3/4")	1	1	1	1
		Ø25 (Ø1")	1	1	1	1
		Ø32 (Ø1 1/4")	1	1	1	1
	Drill	MT 1	Opt.	Opt.	Opt.	Opt.
		MT 2	Opt.	Opt.	Opt.	Opt.
		MT 3	Opt.	Opt.	Opt.	Opt.
	ER Collet		1 Set	1 Set	1 Set	1 Set
	Adapter Set		Opt.	Opt.	Opt.	Opt.

# SPECIFICATIONS

## Tooling System

unit : mm(in)

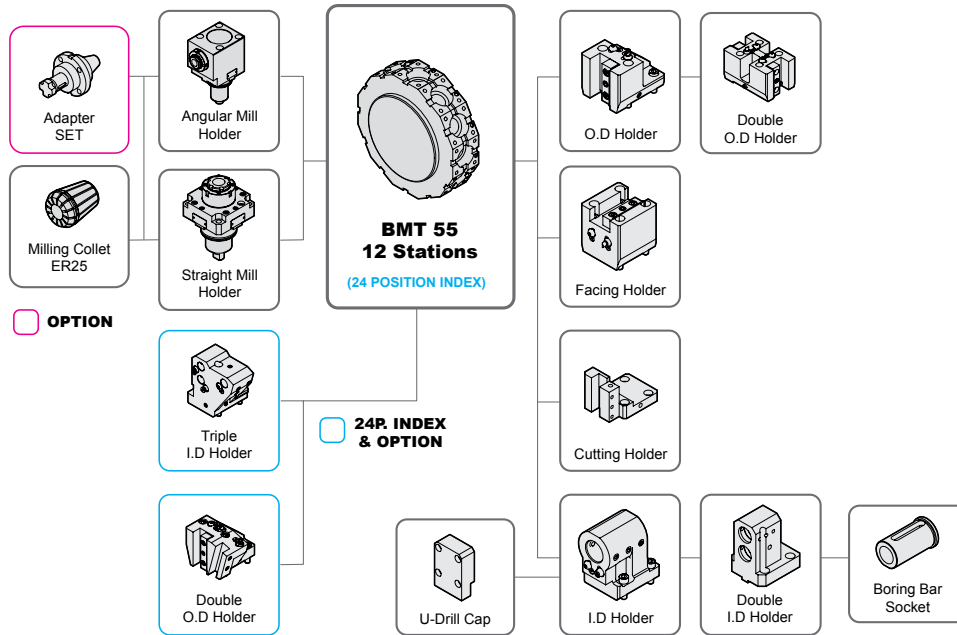

## SE2600SY/LSY - Tooling Parts Detail

ITEM			10 Position		12 Position : Opt.	
			mm Unit	inch Unit	mm Unit	inch Unit
Turning Holder	O.D Holder	Right/Left	2	2	1	1
		Double (Main & Sub)	1	1	-	-
		Double (Main)	-	-	1	1
		Double (Sub)	-	-	1	1
	Facing Holder	1	1	1	1	
	Cutting Holder	1	1	1	1	
Boring Holder	I.D Holder	Single	2	2	2	2
		Double	1	1	-	-
		Triple	-	-	1	1
	U-Drill Holder	Cap	1	1	1	1
Driven Holder	Straight Mill Holder	Standard	2	2	2	2
	Angular Mill Holder	Standard	2	2	2	2
Socket	Main Spindle Boring	Ø10 (Ø3/8")	1	1	1	1
		Ø12 (Ø1/2")	1	1	1	1
		Ø16 (Ø5/8")	1	1	1	1
		Ø20 (Ø3/4")	1	1	1	1
		Ø25 (Ø1")	1	1	1	1
		Ø32 (Ø1 1/4")	1	1	1	1
	Sub Spindle Boring	Ø8 (5/16")	1	1	1	1
		Ø12 (1/2")	1	1	1	1
		Ø16 (5/8")	1	1	1	1
	Drill	MT 1	Opt.	Opt.	Opt.	Opt.
		MT 2	Opt.	Opt.	Opt.	Opt.
		MT 3	Opt.	Opt.	Opt.	Opt.
	ER Collet		1 Set	1 Set	1 Set	1 Set
Adapter Set		Opt.	Opt.	Opt.	Opt.	

Specifications are subject to change without notice for improvement.

# SPECIFICATIONS

## Tooling Travel Range

unit : mm(in)

SE2600

### O.D Tool Holder

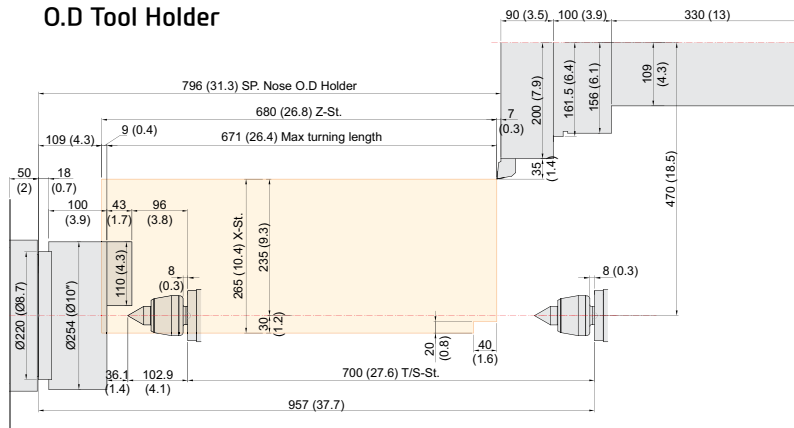

### I.D Tool Holder

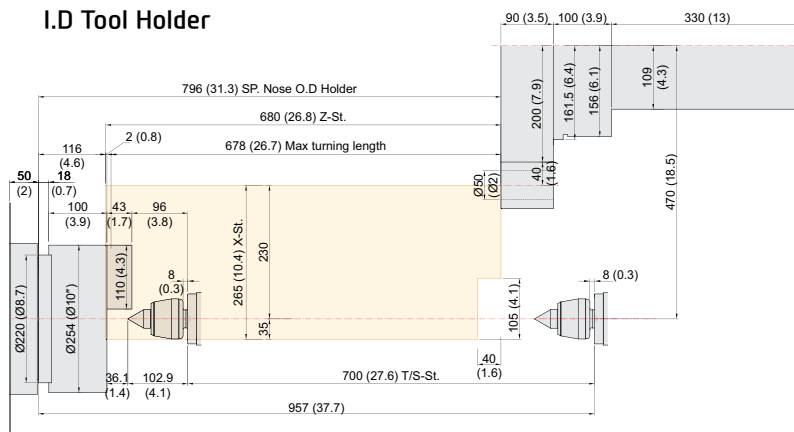

# SPECIFICATIONS

## Tooling Travel Range

unit : mm(in)

### SE2600L

#### O.D Tool Holder

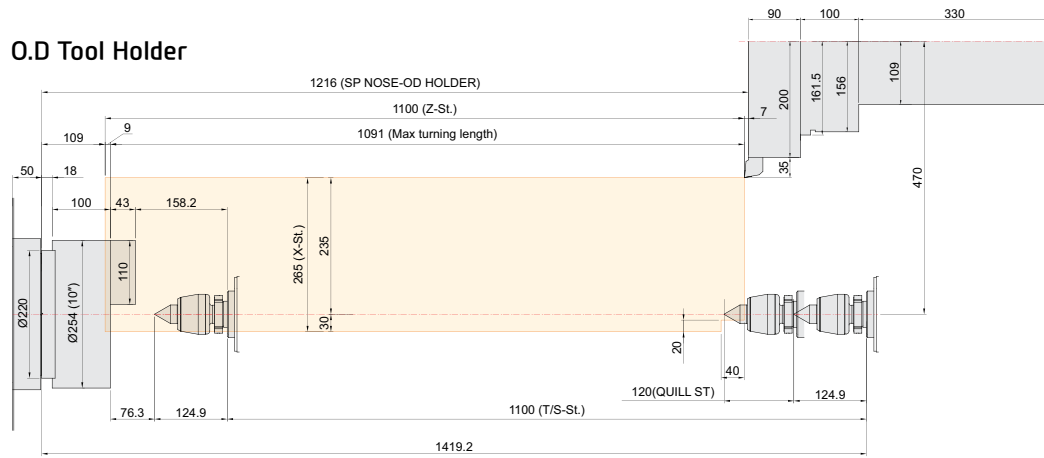

#### I.D Tool Holder

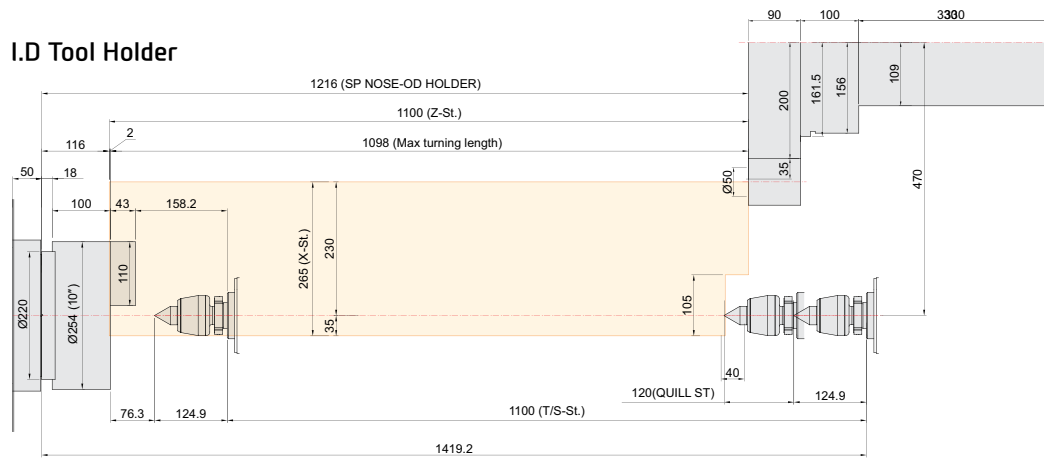

# SPECIFICATIONS

## Tooling Travel Range

unit : mm(in)

### SE2600M

#### O.D Tool Holder

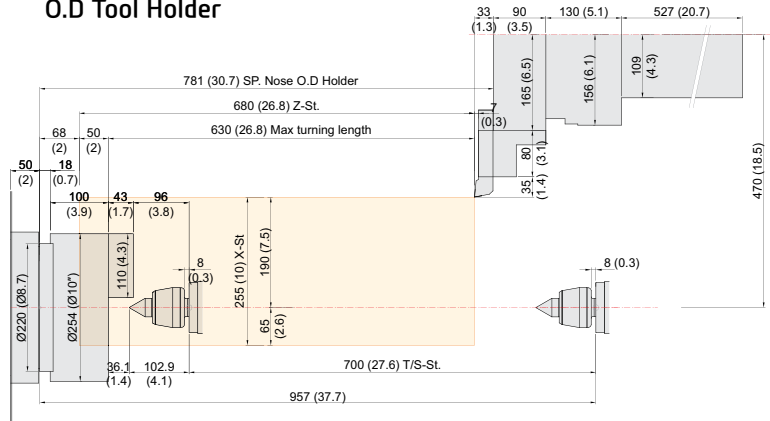

#### I.D Tool Holder

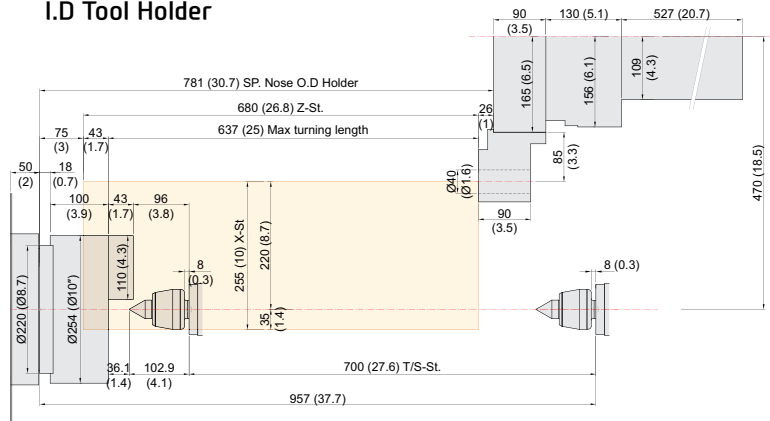

#### Face Tool Holder

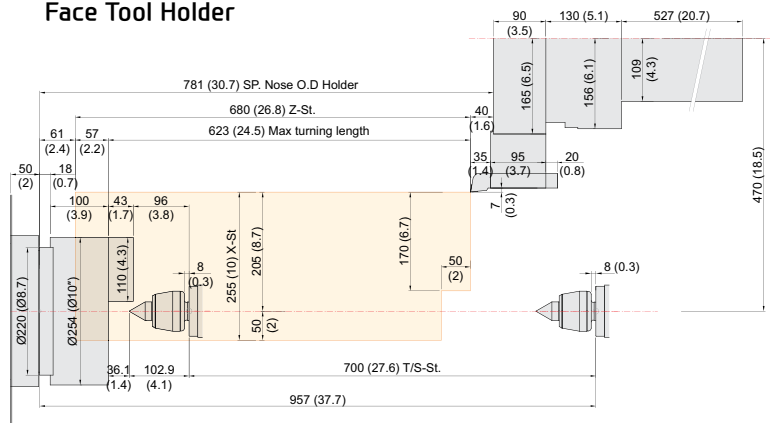

# SPECIFICATIONS

Tooling Travel Range

unit : mm(in)

SE2600M

## Straight Mill Holder

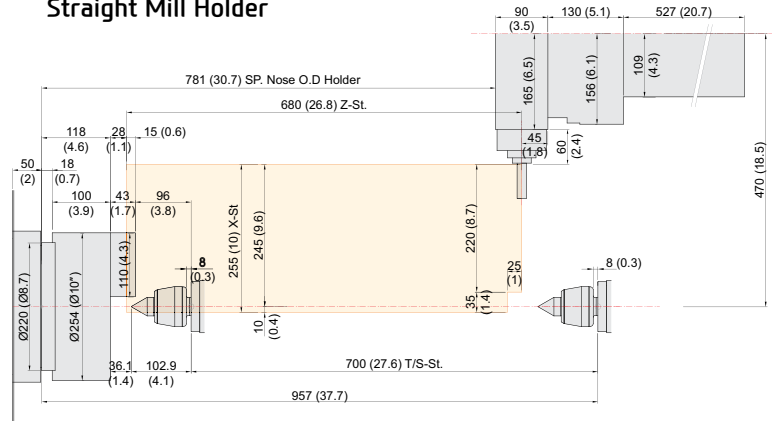

## Angular Mill Holder

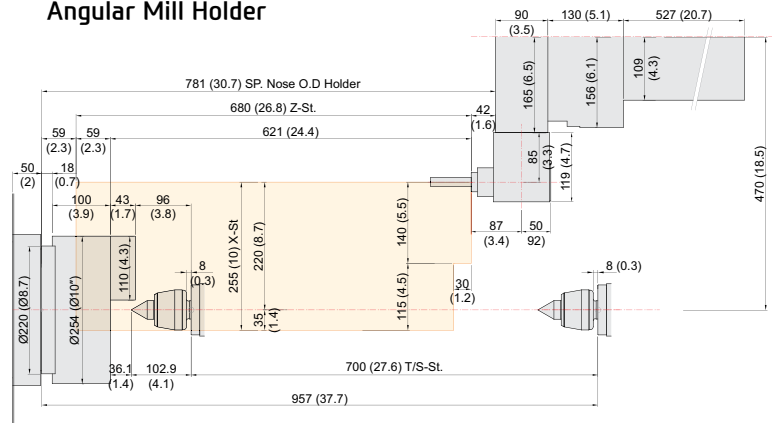

# SPECIFICATIONS

## Tooling Travel Range

unit : mm(in)

### SE2600LM

#### O.D Tool Holder

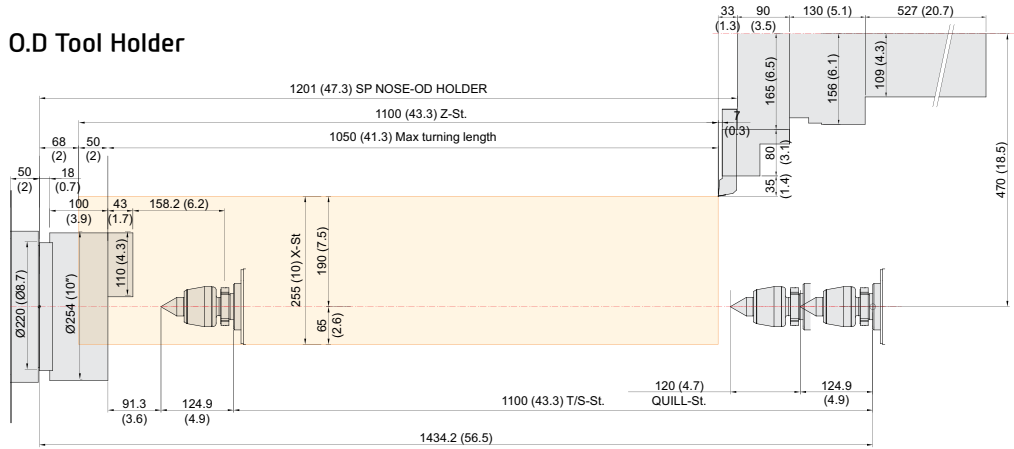

#### I.D Tool Holder

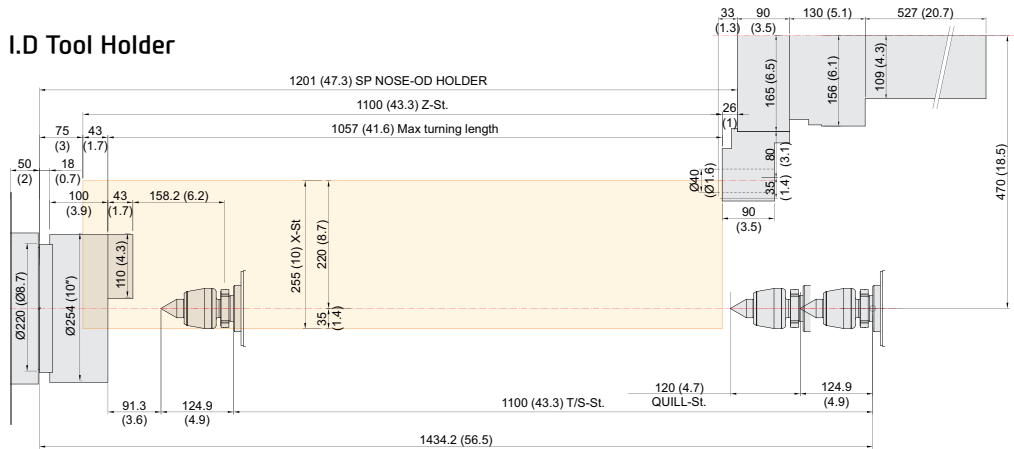

#### Face Tool Holder

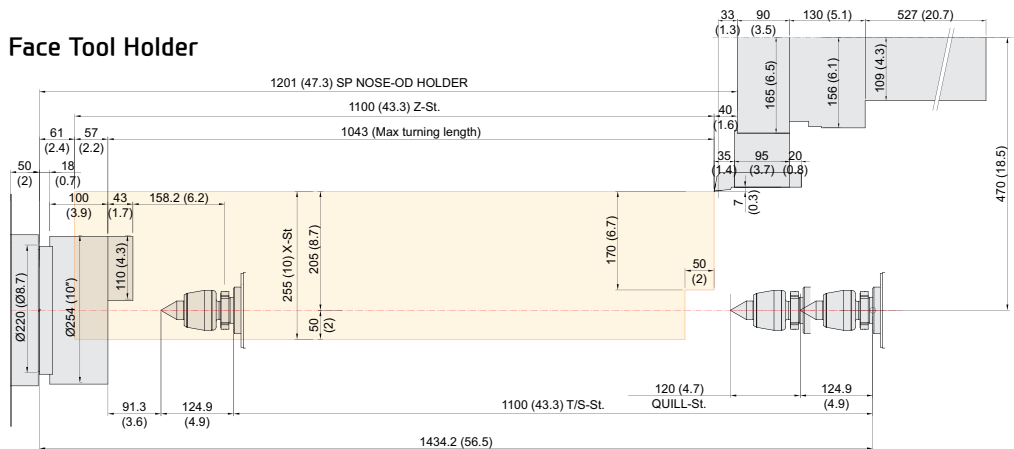

# SPECIFICATIONS

## Tooling Travel Range

unit : mm(in)

### SE2600LM

#### Straight Mill Holder

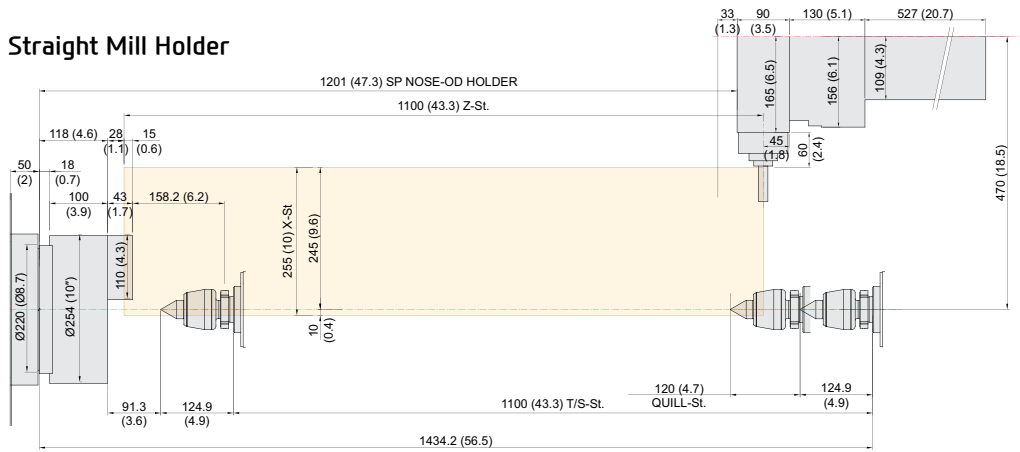

#### Angular Mill Holder

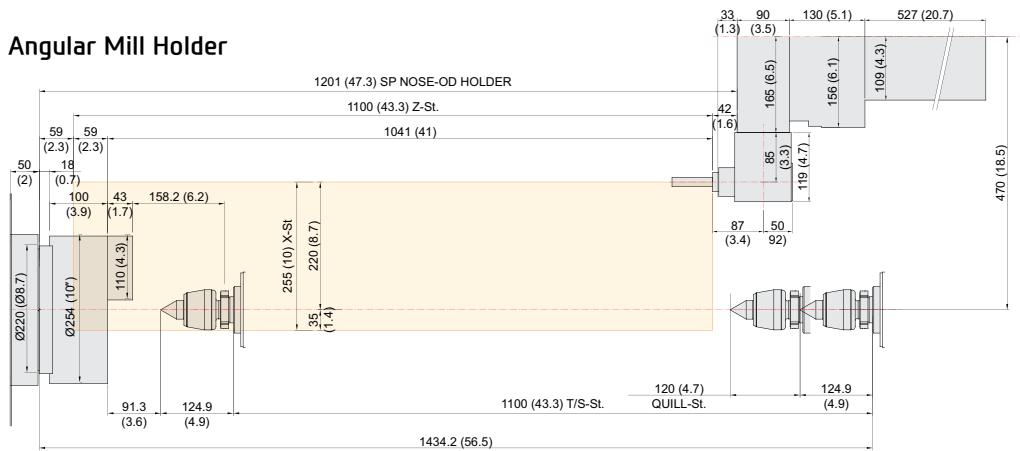

# SPECIFICATIONS

## Tooling Travel Range

unit : mm(in)

SE2600Y

### O.D Tool Holder

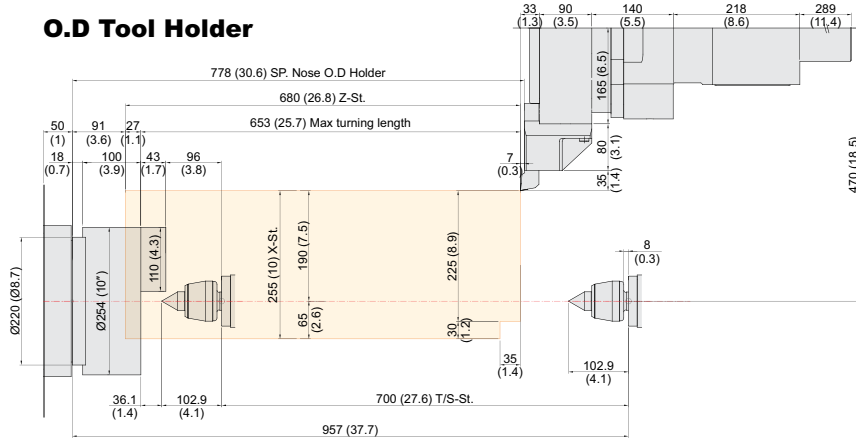

### I.D Tool Holder

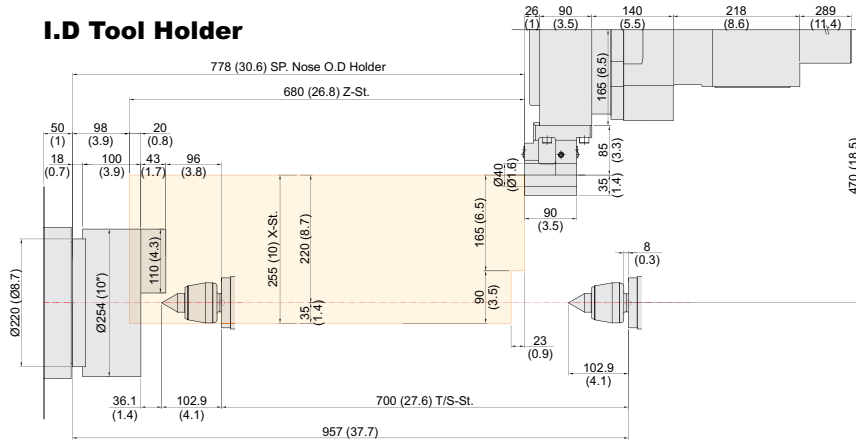

### Face Tool Holder

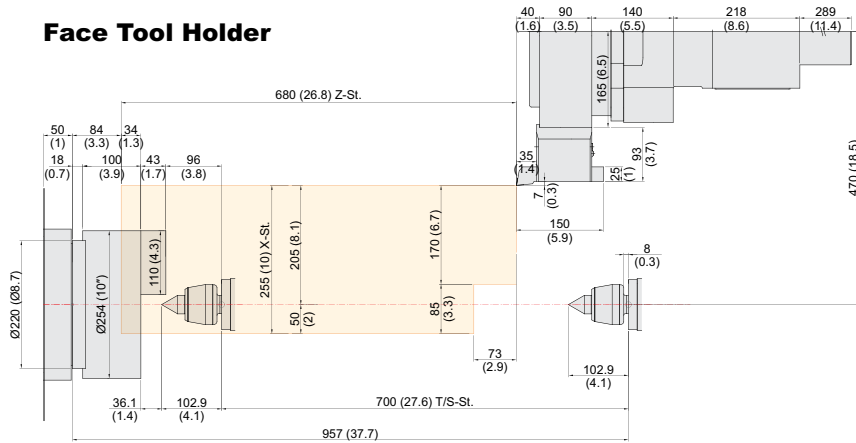

# SPECIFICATIONS

## Tooling Travel Range

unit : mm(in)

SE2600Y

### Straight Mill Holder

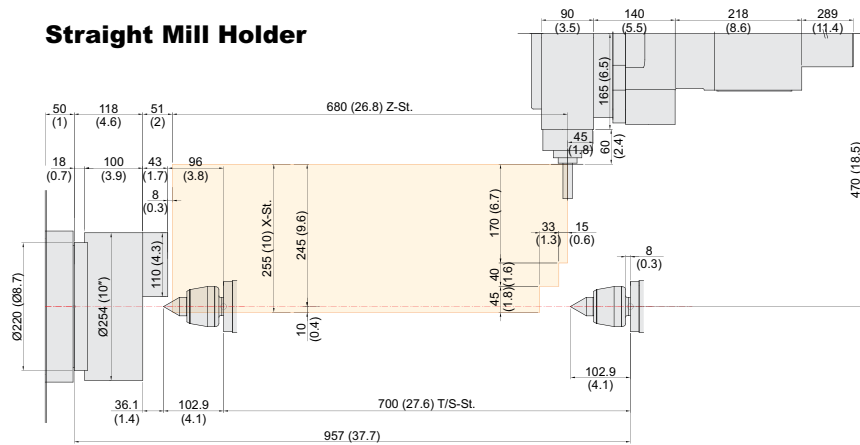

### Angular Mill Holder

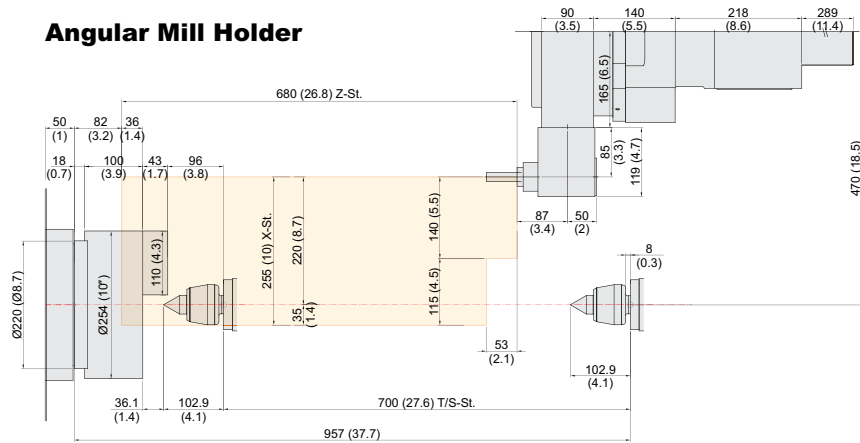

# SPECIFICATIONS

## Tooling Travel Range

unit : mm(in)

### SE2600LY

#### O.D Tool Holder

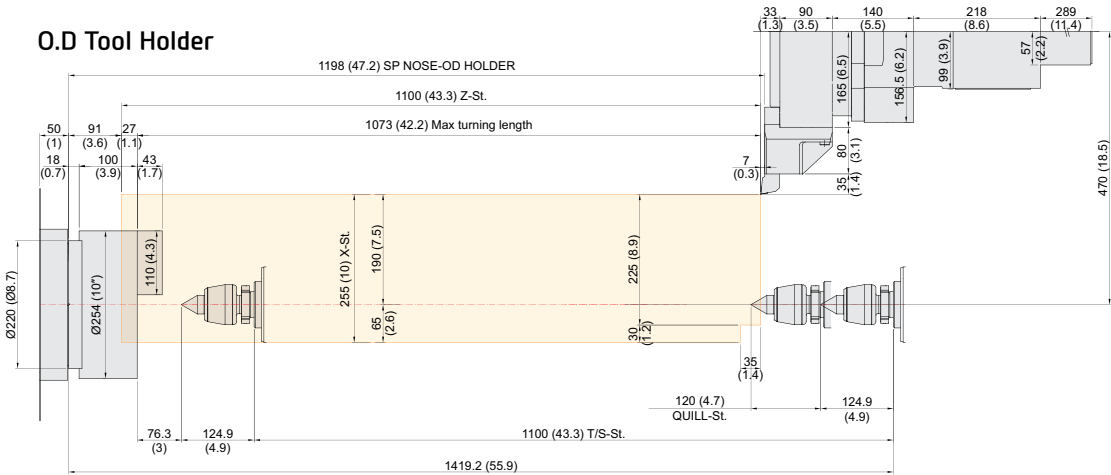

#### I.D Tool Holder

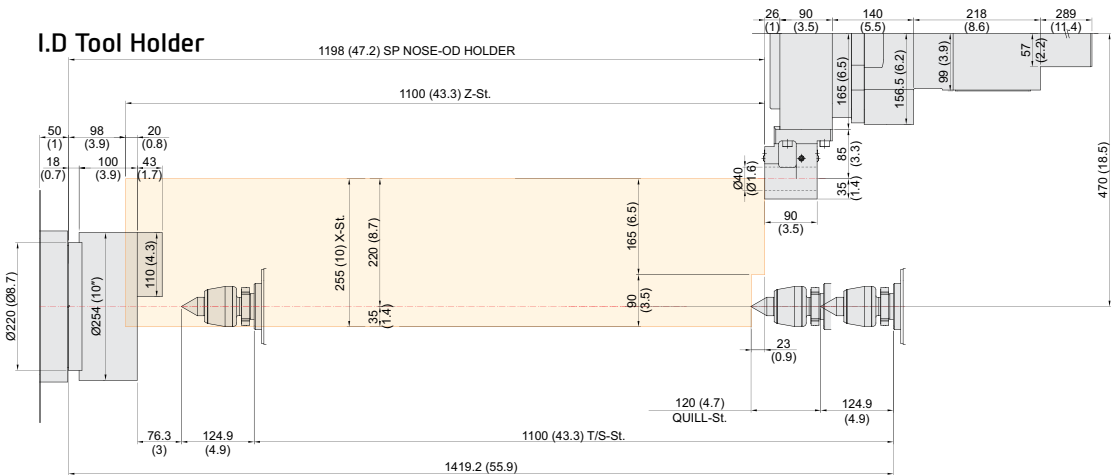

#### Face Tool Holder

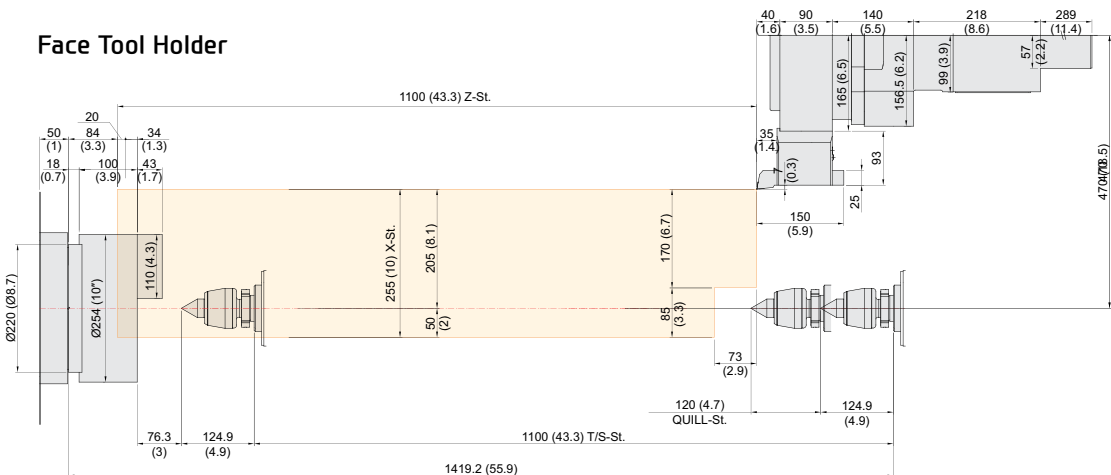

# SPECIFICATIONS

## Tooling Travel Range

unit : mm(in)

### SE2600LY

#### Straight Mill Holder

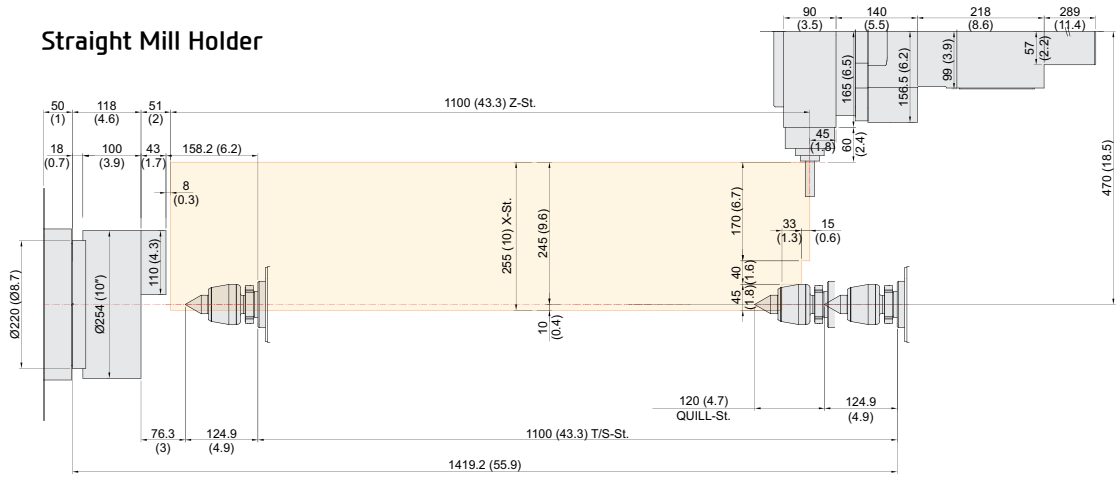

#### Angular Mill Holder

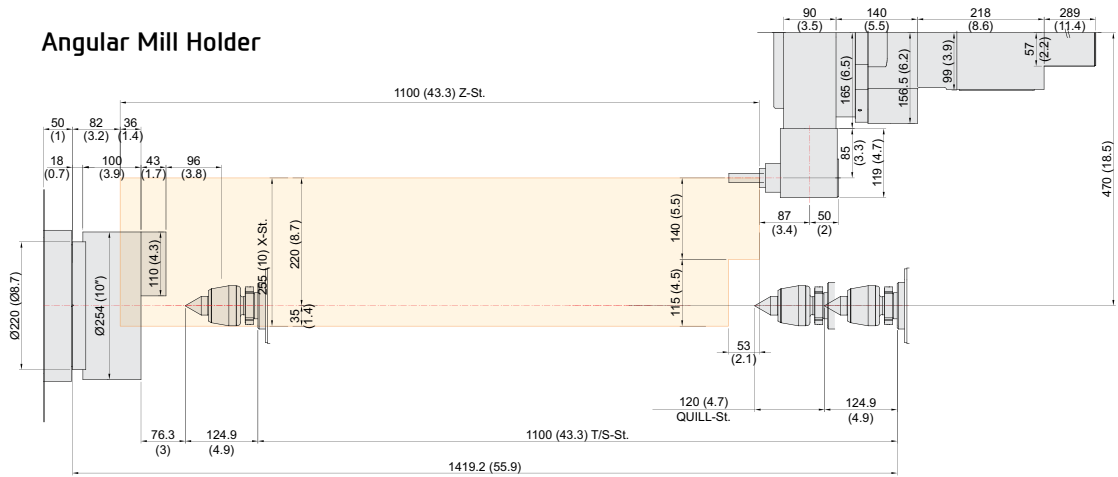



# SPECIFICATIONS

## Tooling Travel Range

unit : mm(in)

### SE2600SY

#### Straight Mill Holder

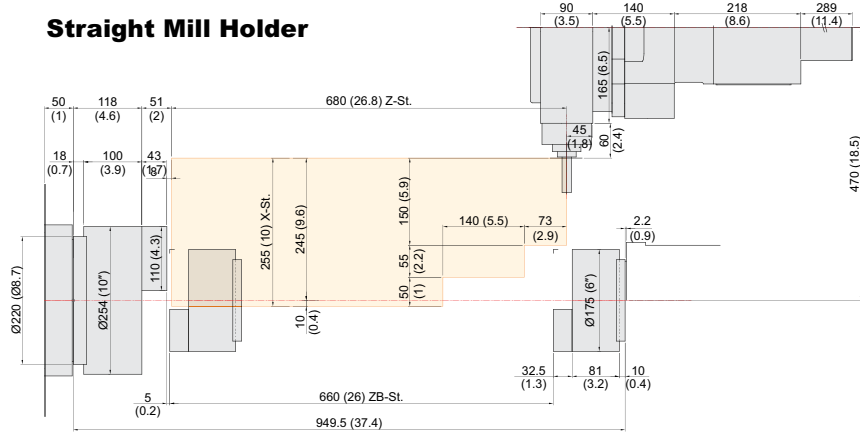

#### Angular Mill Holder

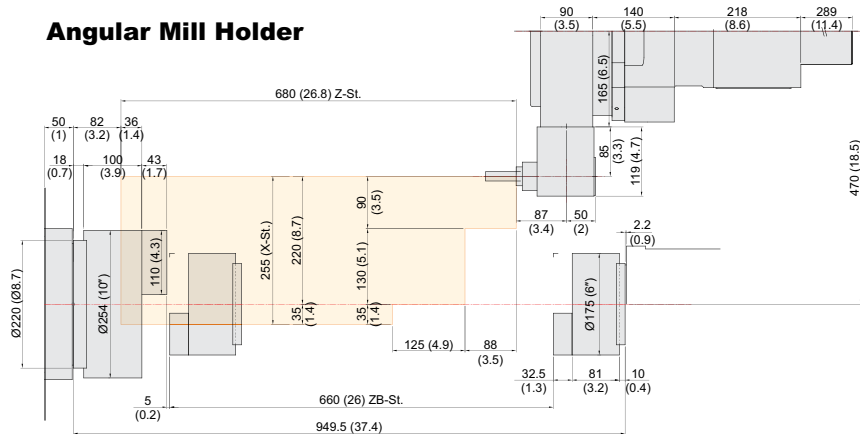

#### Sub Angular Mill Holder

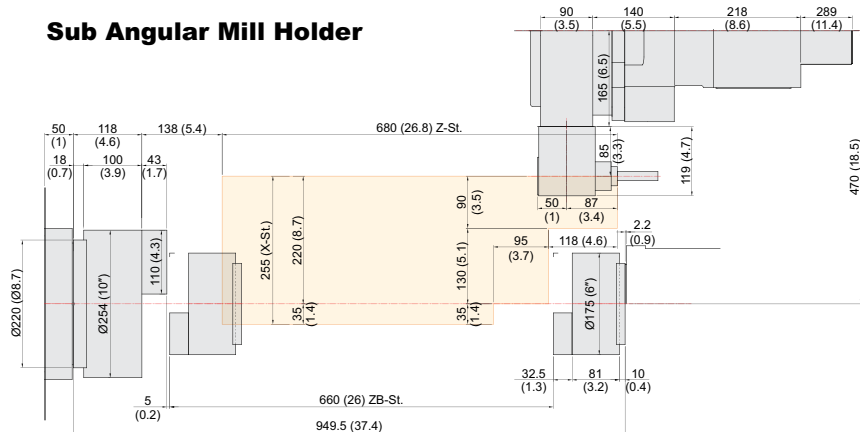

# SPECIFICATIONS

## Tooling Travel Range

unit : mm(in)

### SE2600LSY

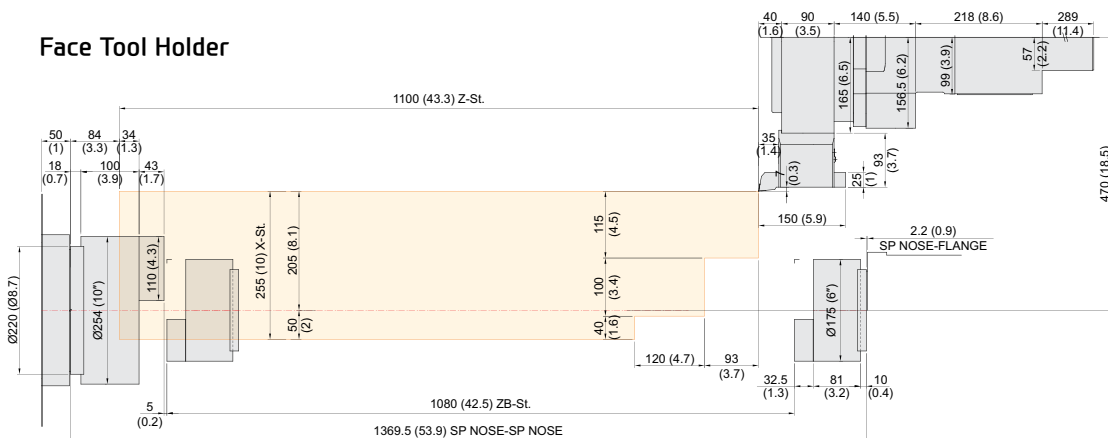
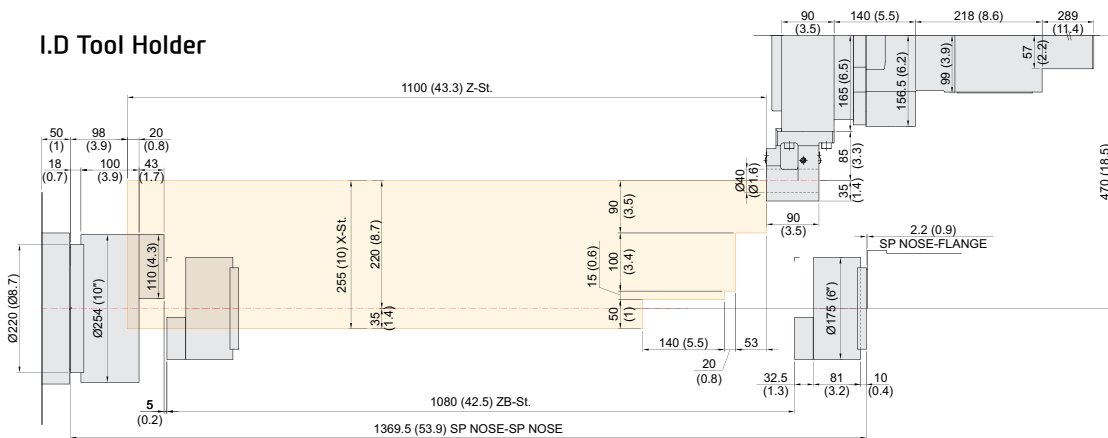
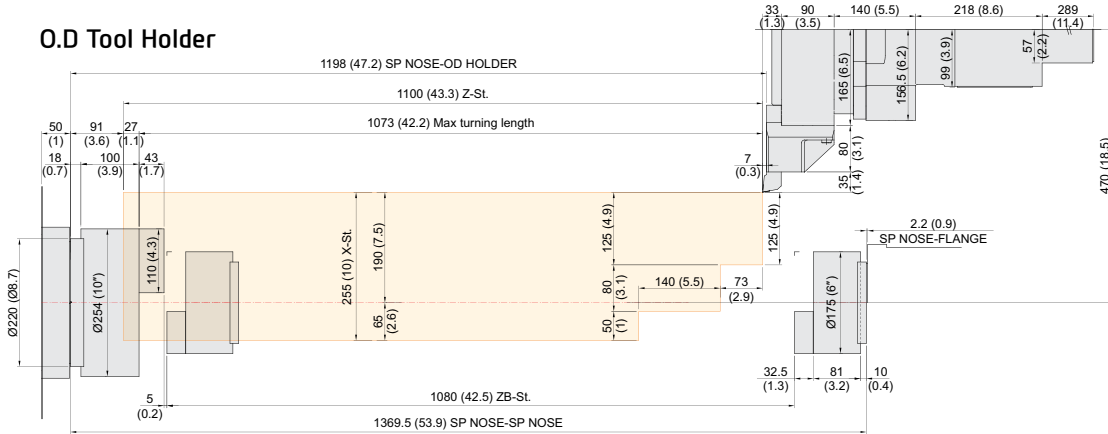



# SPECIFICATIONS

## Specifications

[ ] : Option

MODEL		SE2600	SE2600L	
CAPACITY	Swing Over the Bed	mm(in)	Ø600 (Ø23.6")	
	Swing Over the Carriage	mm(in)	Ø460 (18.1")	
	Max. Turning Dia.	mm(in)	Ø460 (18.1")	
	Max. Turning Length	mm(in)	671 (26.4")	1,091 (43")
	Bar Capacity	mm(in)	Ø81 (3.2")	
SPINDLE	Chuck Size	inch	10"	
	Spindle Bore	mm(in)	Ø91 (3.6")	
	Spindle Speed (rpm)	r/min	3,500 [2,500]	
	Motor (Max/Cont.)	kW(HP)	18.5/11 (25/15) [26/18.5 (35/25)]	
	Torque (Max/Cont.)	N·m (lb·ft)	470.9/286.4 (347.3/211.2) [734/522 (541.4/385)]	
	Spindle Type	-	BELT	
	Spindle Nose	-	A2-8	
	C-axis Indexing	deg	0.001°	
FEED	Travel (X/Z)	mm(in)	265/680 (10.1"/26.8")	265/1,100 (10.1"/43.3")
	Rapid Traverse Rate (X/Z)	m/min (ipm)	30/30 (1,181/1,181)	
	Slide Type	-	ROLLER LM GUIDE	
TURRET	No. of Tools	ea	10 [12]	
	Tool Size	OD	mm(in)	□25 (□1")
		ID	mm(in)	Ø50 (Ø2")
	Indexing Time	sec	0.15	
LIVE TOOL	Motor (Max/Cont.)	kW(HP)	-	
	Milling Tool Speed (rpm)	r/min	-	
	Torque (Max/Cont.)	N·m (lb·ft)	-	
	Collet Size	mm(in)	-	
	Type	-	-	
TAIL STOCK	Taper	-	MT#4	
	Quill Dia.	mm(in)	-	Ø80 (Ø3.1")
	Quill Travel	mm(in)	-	120 (4.7")
	Travel	mm(in)	700 (27.6")	1,100 (43.3")
TANK CAPACITY	Coolant Tank	ℓ(gal)	200 (52.8)	230 (60.8)
	Lubricating Tank	ℓ(gal)	0.7 (0.18)	1.8 (0.48)
POWER SUPPLY	Electric Power Supply	kVA	18	
	Thickness of Power Cable	mm <sup>2</sup>	Over 16	
	Voltage	V/Hz	220/60 (200/50*)	
MACHINE	Floor Space (L×W)	mm(in)	3,255×1,900 (128.1"×74.8")	3,715×2,000 (146.3"×78.7")
	Height	mm(in)	1,730 (68.1")	
	Weight	kg(lb)	4,200 (9,259)	5,000 (11,023)
PC	Controller	-	HYUNDAI WIA FANUC i Series - Smart Plus	

# SPECIFICATIONS

## Specifications

[ ] : Option

MODEL		SE2600M	SE2600LM	
CAPACITY	Swing Over the Bed	mm(in)	Ø600 (Ø23.6")	
	Swing Over the Carriage	mm(in)	Ø460 (18.1")	
	Max. Turning Dia.	mm(in)	Ø380 (15")	
	Max. Turning Length	mm(in)	630 (24.8")	1,050 (41.3")
	Bar Capacity	mm(in)	Ø81 (3.2")	
SPINDLE	Chuck Size	inch	10"	
	Spindle Bore	mm(in)	Ø91 (3.6")	
	Spindle Speed (rpm)	r/min	3,500 [2,500]	
	Motor (Max/Cont.)	kW(HP)	18.5/11 (25/15) [26/18.5 (35/25)]	
	Torque (Max/Cont.)	N·m (lb·ft)	470.9/286.4 (347.3/211.2) [734/522 (541.4/385)]	
	Spindle Type	-	BELT	
	Spindle Nose	-	A2-8	
C-axis Indexing	deg	0.001°		
FEED	Travel (X/Z)	mm(in)	255/680 (10"/26.8")	255/1,100 (10"/43.3")
	Rapid Traverse Rate (X/Z)	m/min (ipm)	30/30 (1,181/1,181)	
	Slide Type	-	ROLLER LM GUIDE	
TURRET	No. of Tools	ea	12 [24]	
	Tool Size	OD	mm(in)	□25 (□1") [24T : □20 (□3/4")]
		ID	mm(in)	SINGLE Ø40 (Ø1 1/2"), DOUBLE Ø20 (Ø3/4") [24T : SINGLE Ø40 (Ø1 1/2"), TRIPLE : Ø20 (Ø3/4")]
	Indexing Time	sec	0.15	
LIVE TOOL	Motor (Max/Cont.)	kW(HP)	5.5/3.7 (7.4/5)	
	Milling Tool Speed (rpm)	r/min	6,000	
	Torque (Max/Cont.)	N·m (lb·ft)	52.5/26.5 (38.7/19.5)	
	Collet Size	mm(in)	Ø16 (Ø5/8") : ER25	
	Type	-	BMT55	
TAIL STOCK	Taper	-	MT#4	
	Quill Dia.	mm(in)	-	Ø80 (Ø3.1")
	Quill Travel	mm(in)	-	120 (4.7")
	Travel	mm(in)	700 (27.6")	1,100 (43.3")
TANK CAPACITY	Coolant Tank	ℓ(gal)	200 (52.8)	230 (60.8)
	Lubricating Tank	ℓ(gal)	0.7 (0.18)	1.8 (0.48)
POWER SUPPLY	Electric Power Supply	kVA	18	
	Thickness of Power Cable	mm <sup>2</sup>	Over 16	
	Voltage	V/Hz	220/60 (200/50*)	
MACHINE	Floor Space (L×W)	mm(in)	3,255×1,900 (128.1"×74.8")	3,715×2,000 (146.3"×78.7")
	Height	mm(in)	1,730 (68.1")	
	Weight	kg(lb)	4,300 (9,480)	5,100 (11,244)
PC	Controller	-	HYUNDAI WIA FANUC i Series - Smart Plus	

Specifications are subject to change without notice for improvement.

# SPECIFICATIONS

## Specifications

[ ] : Option

MODEL		SE2600Y	SE2600LY	
CAPACITY	Swing Over the Bed	mm(in)	Ø630 (Ø24.8")	
	Swing Over the Carriage	mm(in)	Ø630 (Ø24.8")	
	Max. Turning Dia.	mm(in)	Ø380 (15")	
	Max. Turning Length	mm(in)	653 (25.7")	1,073 (42.2")
	Bar Capacity	mm(in)	Ø81 (Ø3.2")	
SPINDLE	Chuck Size	inch	10"	
	Spindle Bore	mm(in)	Ø91 (Ø3.6")	
	Spindle Speed (rpm)	r/min	3,500 [2,500]	
	Motor (Max/Cont.)	kW(HP)	18.5/11 (25/15) [26/18.5 (35/25)]	
	Torque (Max/Cont.)	N·m (lbfft)	470.9/286.4 (347.3/211.2)[734/522 (541.4/385)]	
	Spindle Type	-	BELT	
	Spindle Nose	-	A2-8	
C-axis Indexing	deg	0.001°		
FEED	Travel (X/Y/Z)	mm(in)	255/110{±55}/680 (10"/4.3"/26.8")	255/110{±55}/1,100 (10"/4.3"/43.3")
	Rapid Traverse Rate (X/Y/Z)	m/min (ipm)	30/10/30 (1,181/394/1,181)	30/10/30/15 (1,181/394/1,181/591)
	Slide Type	-	ROLLER LM GUIDE	
TURRET	No. of Tools	ea	12 [24]	
	Tool Size	OD	mm(in)	□ 25 (□ 1") [24T : □ 20 (□ 3/4")]
		ID	mm(in)	SINGLE Ø40 (Ø1 1/2"), DOUBLE Ø20 (Ø3/4") [24T : SINGLE Ø40 (Ø1 1/2"), TRIPLE : Ø20 (Ø3/4")]
	Indexing Time	sec	0.15	
LIVE TOOL	Motor (Max/Cont.)	kW(HP)	5.5/3.7 (7.4/5)	
	Milling Tool Speed (rpm)	r/min	6,000	
	Torque (Max/Cont.)	N·m (lbfft)	52.5/26.5 (38.7/19.5)	
	Collet Size	mm(in)	Ø16 (Ø5/8") : ER25	
	Type	-	BMT55	
TAIL STOCK	Taper	-	MT#4	
	Quill Dia.	mm(in)	-	Ø80 (Ø3.1")
	Quill Travel	mm(in)	-	120 (4.7")
	Travel	mm(in)	700 (27.6")	1,100 (43.3")
TANK CAPACITY	Coolant Tank	ℓ(gal)	200 (52.8)	230 (60.8)
	Lubricating Tank	ℓ(gal)	0.7 (0.18)	1.8 (0.48)
POWER SUPPLY	Electric Power Supply	kVA	22	
	Thickness of Power Cable	mm <sup>2</sup>	Over 16	
	Voltage	V/Hz	220/60 (200/50*)	
MACHINE	Floor Space (L×W)	mm(in)	3,345×2,000 (131.7"×78.7")	3,805×2,100 (149.8"×82.7")
	Height	mm(in)	1,960 (77.2")	
	Weight	kg(lb)	4,800 (10,582)	5,600 (12,346)
PC	Controller	-	HYUNDAI WIA FANUC i Series - Smart Plus	

# SPECIFICATIONS

## Specifications

[ ] : Option

MODEL		SE2600SY	SE2600LSY	
CAPACITY	Swing Over the Bed	mm(in)	Ø630 (Ø24.8")	
	Swing Over the Carriage	mm(in)	Ø630 (Ø24.8")	
	Max. Turning Dia.	mm(in)	Ø380 (15")	
	Max. Turning Length	mm(in)	653 (25.7")	1,073 (42.2")
	Bar Capacity	mm(in)	Main : Ø81 (Ø3.2") Sub : Ø51 (Ø2")	
SPINDLE	Chuck Size	inch	Main : 10" Sub : 6"	
	Spindle Bore	mm(in)	Main : Ø91 (Ø3.6") Sub : Ø60 (Ø2.4")	
	Spindle Speed (rpm)	r/min	Main : 3,500 [2,500] Sub : 4,500	
	Motor (Max/Cont.)	kW(HP)	Main : 18.5/11 (25/15) [26/18.5 (35/25)] Sub : 7.5/5.5 (10/7.5)	
	Torque (Max/Cont.)	N·m (lbfft)	Main : 470.9/286.4 (347.3/211.2) [734/522 (541.4/385)] Sub : 85/47 (62.7/34.7)	
	Spindle Type	-	BELT	
	Spindle Nose	-	Main : A2-8 Sub : A2-5	
	C-axis Indexing	deg	0.001°	
FEED	Travel (X/Y/Z/ZB)	mm(in)	255/110 (±55)/680/660 (10"/4.3"/26.8"/26")	255/110 (±55)/1,100/1,080 (10"/4.3"/43.3"/42.5")
	Rapid Traverse Rate (X/Y/Z/ZB)	m/min (ipm)	30/10/30/15 (1,181/394/1,181/591)	
	Slide Type	-	ROLLER LM GUIDE	
TURRET	No. of Tools	ea	12 [24]	
	Tool Size	OD	mm(in)	□ 25 (□ 1") [24T : □ 20 (□ 3/4")]
		ID	mm(in)	SINGLE Ø40 (Ø1 1/2"), DOUBLE Ø20 (Ø3/4") [24T : SINGLE Ø40 (Ø1 1/2"), TRIPLE : Ø20 (Ø3/4")]
	Indexing Time	sec	0.15	
LIVE TOOL	Motor (Max/Cont.)	kW(HP)	5.5/3.7 (7.4/5)	
	Milling Tool Speed (rpm)	r/min	6,000	
	Torque (Max/Cont.)	N·m (lbfft)	52.5/26.5 (38.7/19.5)	
	Collet Size	mm(in)	Ø16 (Ø5/8") : ER25	
	Type	-	BMT55	
TAIL STOCK	Taper	-	-	
	Quill Dia.	mm(in)	-	
	Travel	mm(in)	-	
TANK CAPACITY	Coolant Tank	ℓ(gal)	200 (52.8)	230 (60.8)
	Lubricating Tank	ℓ(gal)	0.7 (0.18)	
POWER SUPPLY	Electric Power Supply	kVA	22	28
	Thickness of Power Cable	mm <sup>2</sup>	Over 16	Over 25
	Voltage	V/Hz	220/60 (200/50*)	
MACHINE	Floor Space (L×W)	mm(in)	3,345×2,000 (131.7"×78.7")	3,805×2,100 (149.8"×82.7")
	Height	mm(in)	1,960 (77.2")	
	Weight	kg(lb)	5,000 (11,023)	5,800 (12,787)
PC	Controller	-	HYUNDAI WIA FANUC i Series - Smart Plus	

Specifications are subject to change without notice for improvement.

# CONTROLLER

## HYUNDAI WIA FANUC – Smart Plus

[ ] : Option

Controlled axis / Display / Accuracy Compensation	
Control axis	2 axis (X, Z) / 3 axis (X, Z, C) / 4 axis (X, Z, Y, C) 5 axis (X, Z, B, C, A) / 6 axis (X, Z, Y, B, C, A) 7 axis (X1/Z1, X2/Z2, B2, C1/C2)
Simultaneously controlled axis	2 axis [Max. 4 axis]
Designation of spindle axis	3 axis [Max. 4 axis]
Least setting Unit	X, Z, Y, B axis : 0.001 mm (0.0001 inch) C, A axis : 0.001 deg
Least input increment	X, Z, Y, B axis : 0.001 mm (0.0001 inch) C, A axis : 0.001 deg
Inch / Metric conversion	G20 / G21
High response vector control	
Interlock	All axis / Each axis
Machine lock	All axis
Backlash compensation	± 0~9999 pulses (exc. Rapid traverse / Cutting feed)
Position switch	
LCD / MDI	15 inch LCD unit (with Touch Panel)
Feedback	Absolute motor feedback
Stored stroke check 1	Over travel
Stored stroke check 2, 3	
PMC axis control	
Operation	
Automatic operation (Memory)	
MDI operation	
DNC operation	Needed DNC software / CF card
Program restart	
Wrong operation prevention	
Program check function	Dry run
Single block	
Search function	Program Number / Sequence Number
Interpolation functions	
Pano interpolation	
Positioning	G00
Linear interpolation	G01
Circular interpolation	G02, G03
Exact stop mode	Single : G09, Continuous : G61
Dwell	G04, 0 ~ 9999.9999 sec
Skip	G31
Reference position return	1st reference : G28, 2nd reference : G30 Ref. position check : G27
Thread synchronous cutting	G33
Thread cutting retract	
Variable lead thread cutting	
Multi / Continuous threading	
Feed function / Acc. & Dec. control	
Manual feed	Rapid traverse Jog : 0~2,000 mm/min (79 ipm) Manual handle : x1, x10, x100 pulses Reference position return
Cutting Feed command	Direct input F code
Feedrate override	0 ~ 200% (10% Unit)
Rapid traverse override	1%, F25%, 50%, 100%
Override cancel	
Feed per minute	G98
Feed per revolution	G99
Look-ahead block	1 block
Program input	
Tape Code	EIA / ISO
Optional block skip	9 ea
Program stop / end	M00, M01 / M02, M30
Maximum command unit	± 999,999.999 mm (± 99,999.9999 inch)
Plane selection	X-Y : G17 / Z-X : G18 / Y-Z : G19
Workpiece coordinate system	G52, G53, 6 pairs (G54 ~ G59)
Manual absolute	Fixed ON
Programmable data input	G10
Sub program call	10 folds nested
Custom macro	#100 ~ #199, #500 ~ #999
G code system	A, B/C
Programmable mirror image	G51.1, G50.1
G code preventing buffering	G4.1
Direct drawing dimension program	Including Chamfering / Corner R
Conversational Program	SmartGuide-i

Program input	
Multiple repetitive cycles	1, 11
Canned cycle for turning	
Auxiliary function / Spindle speed function	
Auxiliary function	M & 4 digit
Level-up M Code	High speed / Multi / Bypass M code
Spindle speed function	S & 5 digit, Binary output
Spindle override	0% ~ 150% (10% Unit)
Multi position spindle orientation	M19 (S##)
Rigid tapping	
Constant surface speed control	G96, G97
Tool function / Tool compensation	
Tool function	T & 2 digit + Offset 2 digit
Tool life management	
Tool offset pairs	128 pairs
Tool nose radius compensation	G40, G41, G42
Geometry / Wear compensation	
Direct input of offset measured B	
Editing function	
Part program storage size	5,120m (2MB)
No. of registerable programs	1,000 ea
Program protect	
Background editing	
Extended part program editing	Copy, move and change of NC program
Memory card program edit	
Data input / output & Interface	
I/O interface	CF card, USB memory Embedded Ethernet interface
Screen hard copy	
External message	
External key input	
External workpiece number search	
Automatic data backup	
Setting, display and diagnosis	
Self-diagnosis function	
History display & Operation	Alarm & Operator message & Operation
Run hour / Parts count display	
Maintenance information	
Actual cutting feedrate display	
Display of spindle speed / T code	
Graphic display	
Operating monitor screen	Spindle / Servo load etc.
Power consumption monitoring	Spindle & Servo
Spindle / Servo setting screen	
Multi language display	Support 24 languages
Display language switching	Selection of 5 optional Languages
LCD Screen Saver	Screen saver
Unexpected disturbance torque	BST (Back spin torque limit)
Function for machine type	
Cs contour control (C & A axis)	Mill, MS, Y, SY, LF-Mill, TTMS, TTSY
Polar coordinate interpolation	Mill, MS, Y, SY, LF-Mill, TTMS, TTSY
Cylindrical interpolation	Mill, MS, Y, SY, LF-Mill, TTMS, TTSY
Polygon turning (2 Spindles)	Mill, MS, Y, SY, LF-Mill, TTMS, TTSY
Canned cycle for drilling	Mill, MS, Y, SY, LF-Mill, TTMS, TTSY
Spindle orientation expansion	MS, SY TTS, TTMS, TTSY
Spindle synchronous control	MS, SY TTS, TTMS, TTSY
Torque control	MS, SY TTS, TTMS, TTSY
Y axis offset	Y, SY, TTSY
Arbitrary angular control	Y, SY, TTSY
Composite / Superimposed control	MS, SY, TTS, TTMS, TTSY
Balance cutting	TTS, TTMS, TTSY
Option	
Fast ethernet	Needed option board
Data server	Needed option board
Protection of data at 8 levels	
Tool offset pairs	200 pairs
Helical interpolation	
Optional block skip	40 ea, 200 ea (AICC 11)

Figures in inch are converted from metric values.

The FANUC controller specifications are subject to change based on the policy of company CNC supplying.

# HYUNDAI WIA ECO SYSTEM

## MQL (Minimal Quantity Lubrication)

The goal of this system is to spray only the amount of lubricant required to prevent heat and chip build up at the cutting tool or work piece face.

### Example of Turning Center Application

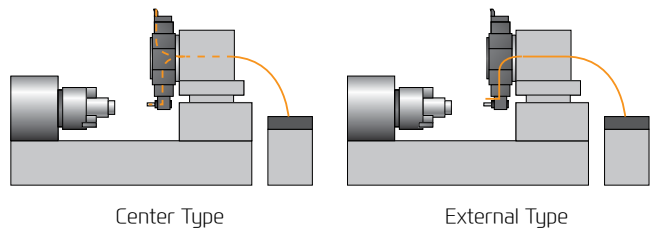

### Example of Etc.

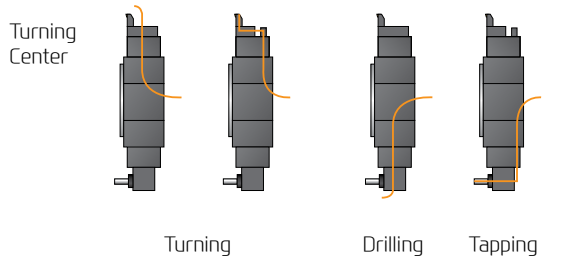

Oil Skimmer

An oil skimmer can increase coolant and tool life by removing tramp oil contaminants.



Mist Collector

Mist Collector reduces the amount of smoke and oil mist in the air. This helps build a safe and comfortable working environment and improve durability.

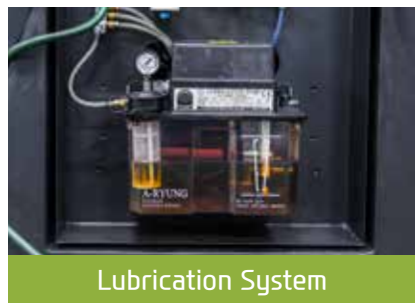

Lubrication System

By applying lubricant only when the machines axis are moving lubrication consumption is reduced by compared to standard systems.

# HYUNDAI WIA ENERGY SAVING

## HW-ESS (HYUNDAI WIA Energy Saving System)

HYUNDAI WIA Machine tool provides the optimum power saving function that can easily save energy with an intuitive user interface.



1. **Machine-ready power saving function** : Put all servo motors and other motors into sleep mode when no control or operation is done for a set time
2. **Work light auto-off function** : The work light is turned off automatically when no control or operation is done for a set time
3. **Chip conveyor auto power saving** : Operation/non operation time (timer) can be set to save energy
4. **Auto Power-off** : Auto power off after ending the an operation after a period of time
5. **Eco function** : Machine ready sleep mode can be activated/de-activated from the controller panel
6. **Power consumption monitor** : Real time power consumption can be monitored through the OP screen



**You Tube HYUNDAI WIA MT**  
[www.youtube.com/HYUNDAIWIAMT](http://www.youtube.com/HYUNDAIWIAMT)

## CREATING VALUE IN SEAMLESS MOBILITY

With its top-quality HYUNDAI WIA machine tool creates a new and better world.



<http://machine.hyundai-wia.com>  
HYUNDAI WIA Machine Tools  
Global Links

### HEADQUARTER

**R&D Center/Factory** 153, Jeongdong-ro, Seongsan-gu, Changwon-si, Gyeongsangnam-do, Korea TEL : +82 55 280 9114 FAX : +82 55 282 9114

**Overseas Sales Team /R&D Center** 37, Cheoldobangmulgwan-ro, Uiwang-si, Gyeonggi-do, Korea TEL : +82 31 8090 2539

### OVERSEAS OFFICES

**HYUNDAI WIA Machine America corp.** 450 Commerce Blvd, Carlstadt, NJ 07072, USA TEL : +1-201-987-7298

**HYUNDAI WIA Europe GmbH** Alexander-Fleming-Ring 57, 65428 Rüsselsheim Germany TEL : +49-0-6142-9256-0

**HYUNDAI WIA Machine Tools China** Company No.16 Fenghuang Road, Fenghuang Town, Zhangjiagang City, Jiangsu Province, China TEL : +86-21-6427-9885

**India Branch Office** #4/169, 1st Floor, LOTTE BLDG, Rajiv Gandhi Salai, (OMR), Kandanchavadi, Chennai - 600096, Tamilnadu, India TEL : +91-76-0490-3348