

HYUNDAI WIA

High Speed & Productivity Vertical Machining Center

# KF-II Series

KF4600 II | KF5600 II | KF6700 II | KF5600L II | KF5600/50 II | KF6700/50 II

# Technical Leader

## State-of-the-art Vertical Machining Center with High-speed and large work space

The Vertical Machining Center KF-II Series, designed by Hyundai WIA with years of expertise and the latest technology, maximizes productivity while maintaining rigidity and accuracy.

ITEM	Direct Spindle					Tool Shank		ATC			
	8,000	*8,000	10,000	12,000	15,000	BBT40	BBT50	24 EA	30 EA	40 EA	60 EA
KF4600 II	●	○	○	○	○	●			●	○	
KF5600 II	●	○	○	○	○	●			●	○	○
KF6700 II	●	○	○	○	○	●			●	○	○
KF5600L II	●	○	○	○	○	●			●	○	
KF5600/50 II		●					●	●			
KF6700/50 II		●					●	●	○		

\* High-Torque Spindle

● : Standard ○ : Option

# KF-II Series

## High Speed & Productivity Vertical Machining Center

- High-precision machining by improved spindle quality
- High-speed roller type LM guide in all axis
- Enhanced chip processing capabilities by applying the upper-type conveyor
- Various motors and columns provided for customized machining
- Improved user convenience by applying the latest controller of FANUC



# 01 BASIC STRUCTURE

High Speed & Productivity Vertical Machining Center

## Magazine

- BBT40
  - Max. Tool Length : 300 mm (11.8")
  - Max. Tool Dia. : Ø125 (Ø4.9")
  - Max. Tool Weight : 8kg (17.6 lb)
- BBT50
  - Max. Tool Length : 350 mm
  - Max. Tool Dia. : Ø250 (Ø9.8")
  - Max. Tool Weight : 15kg (33 lb)

## High Precision Spindle

- BBT40 : KF4600 II, KF5600 II, KF5600L II, KF6700 II
- BBT50 : KF5600/50 II, KF6700/50 II
- Spindle Type : Direct

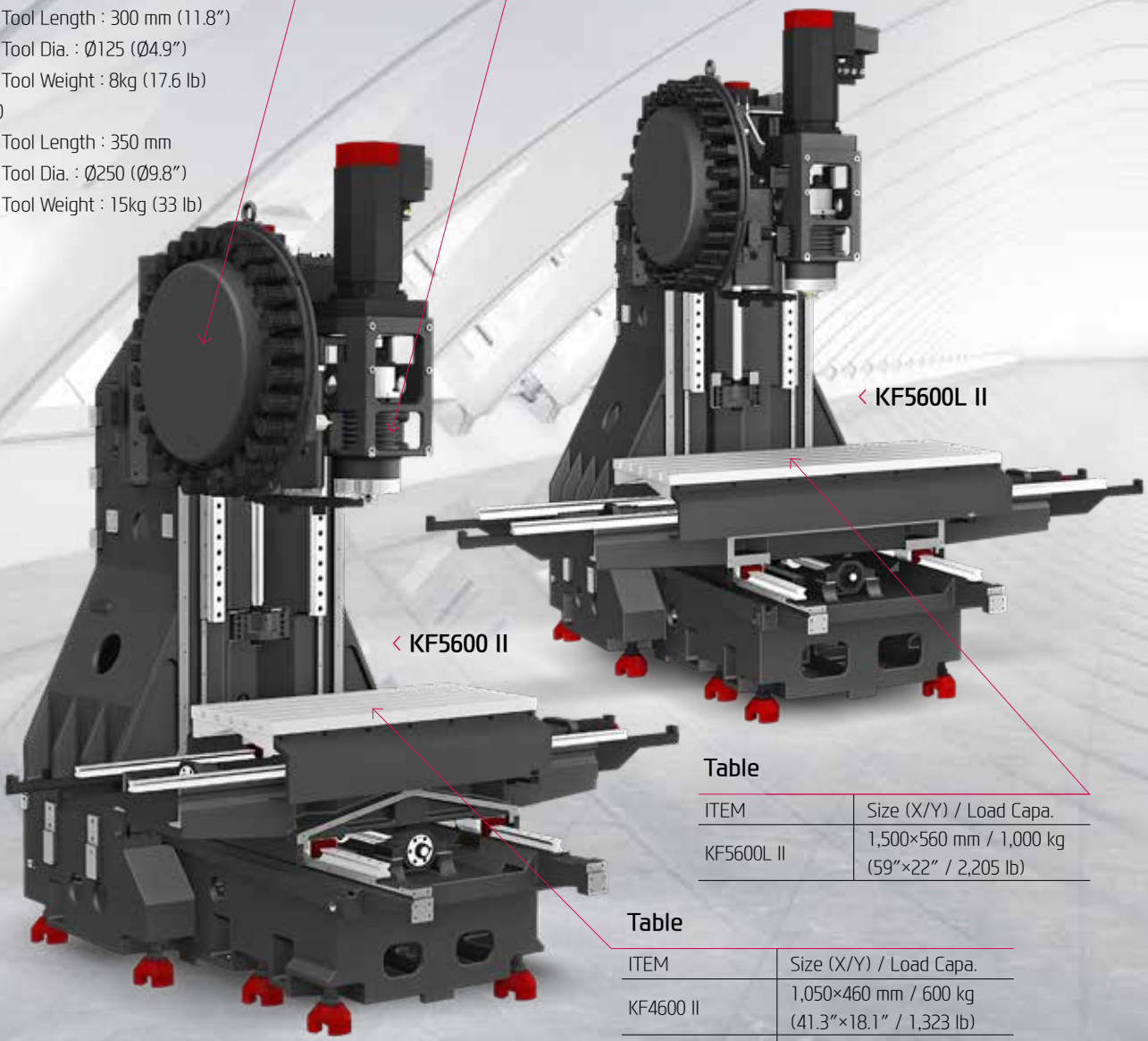

## Table

ITEM	Size (X/Y) / Load Capa.
KF5600L II	1,500×560 mm / 1,000 kg (59"×22" / 2,205 lb)

## Table

ITEM	Size (X/Y) / Load Capa.
KF4600 II	1,050×460 mm / 600 kg (41.3"×18.1" / 1,323 lb)
KF5600 II Series	1,250×560 mm / 1,000 kg (49.2"×22" / 2,205 lb)
KF6700 II Series	1,500×670 mm / 1,300 kg (59"×26.4" / 2,866 lb)

# HIGH-PRECISION, SPEED & LARGE WORKING AREA

## HIGH-PRECISION STRUCTURE

### Optimal Structural Analysis

KF-II Series is designed to have optimal structure through Hyundai WIA's unique structural analysis.

In particular, enhancement of bed and column's rigidity makes excellent performance even in heavy duty cutting.

### One Piece High Column (Direct Sp.)

One piece high column is provided as an option up to z-axis height. This option helps to process bigger products such as rack housing.

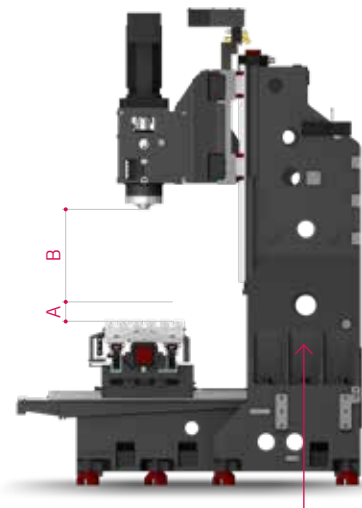

### Incomparably Strong Rigidity Compared to the Block-type High Column

ITEM		Travel of Z-Axis	Height of High Column	A	B
KF4600 II	Std. Column	520 mm (20.5")	-	150 mm (5.9")	150~670 mm (5.9"~26.4")
	High Column	520 mm (20.5")	200 mm (7.9")	350 mm (13.8")	350~870 mm (13.8"~34.3")
KF5600 II	Std. Column	520 mm (20.5")	-	150 mm (5.9")	150~670 mm (5.9"~26.4")
	Opt. 635mm	635 mm (25")	-	150 mm (5.9")	150~785 mm (5.9"~30.9")
	High Column	635 mm (25")	300 mm (7.9")	450 mm (17.7")	450~1,085mm (17.7"~42.7")
KF5600/50 II	Std. Column	520 mm (20.5")	-	200 mm (7.9")	200~720 mm (7.9"~28.3")
	Opt. 635mm	635 mm (25")	-	200 mm (7.9")	200~835 mm (7.9"~32.9")
	High Column	635 mm (25")	300 mm (7.9")	500 mm (19.7")	500~1,135mm (19.7"~44.7")
KF6700 II	Std. Column	635 mm (25")	-	150 mm (5.9")	150~785 mm (5.9"~30.9")
	High Column	635 mm (25")	300 mm (7.9")	500 mm (19.7")	450~1,085mm (17.7"~42.7")
KF6700/50 II	Std. Column	635 mm (25")	-	200 mm (7.9")	200~835 mm (7.9"~32.9")
	High Column	635 mm (25")	300 mm (7.9")	500 mm (19.7")	500~1,135mm (19.7"~44.7")
KF5600L II	Std. Column	520 mm (20.5")	-	150 mm (5.9")	150~670 mm (5.9"~26.4")

- High column can be applied to column with Z-axis traverse distance of 635mm for KF5600 II (520mm Standard column + 300mm High column cannot be applied)

◆ High Column : Option

# 02 HIGH-SPEED FEED

Highest Quality, High-speed Vertical Machining Center

[ ] : Option

## Travel (X/Y/Z)

KF4600 II

**900/460/520** mm  
(35.4"/18.1"/20.5")

KF5600 II

**1,100/560/520 [635]** mm  
(43.3"/22"/20.5" [25"])

KF6700 II

**1,300/670/635** mm  
(51.2"/26.4"/25")

KF5600L II

**1,300/560/520** mm  
(51.2"/22"/20.5")

KF5600/50 II

**1,100/560/520** mm  
(43.3"/22"/20.5")

KF6700/50 II

**1,300/670/635** mm  
(51.2"/26.4"/25")

## Rapid Traverse Rate (X/Y/Z)

KF4600 II

**36/36/30** m/min  
(1,417/1,417/1,181 ipm)

KF5600 II

**36/36/30** m/min  
(1,417/1,417/1,181 ipm)

KF6700 II

**36/36/30** m/min  
(1,417/1,417/1,181 ipm)

KF5600L II

**36/36/30** m/min  
(1,417/1,417/1,181 ipm)

KF5600/50 II

**36/36/30** m/min  
(1,417/1,417/1,181 ipm)

KF6700/50 II

**36/36/30** m/min  
(1,417/1,417/1,181 ipm)

# REDUCED NON-CUTTING TIME & IMPROVED FEED PRECISION

## GUIDE WAY

### High-Speed Roller LM Guideway

Linear roller guideways are applied to reduce non-cutting time and bring high rigidity. Each axis is directly connected to a highly reliable digital servo motor to provide high rigidity and minimal thermal displacement.

### Improvement in Slide Cover

The increased slope of slide cover makes chip disposal easier and minimizes slide cover breakage.



### Double Anchored Ball Screw

The pretensioned ball screw minimizes the expansion and contraction according to the heat and further reinforces the rigidity by the double anchor support method.

In addition, the coupling of the ballscrews and the highly reliable digital servo motors are connected by **metal plate couplings**, to reduce coupling breakage and backlash.

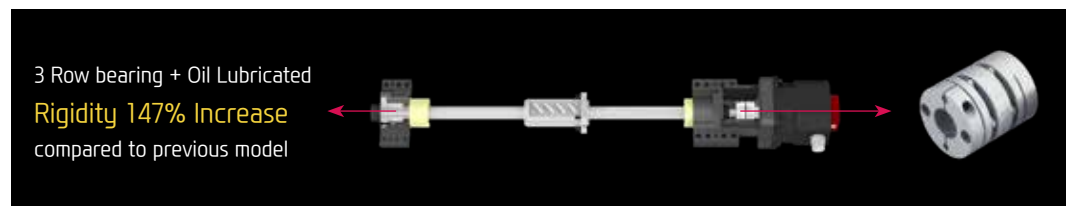

### Increase in Durability of Z-axis ball screw

Lifetime of the bearing has been greatly increased by optimizing the spindle structure and lubrication method.

※ Customer Actual Data

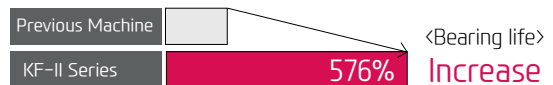

# 03 HIGH PRECISION SPINDLE

Excellent machining performance with high-precision spindle

## KF4600 II/5600 II/6700 II Spindle Specifications

PC	Speed r/min	Motor (Max./Cont.)	Torque (Max./Cont.)	Type
HYUNDAI WIA FAHUC SMART PLUS	8,000/10,000 rpm	18.5/11 kW (25/15 HP)	118/52.5 N·m (87/38.7 lbf·ft)	Direct
	8,000 rpm (KF6700 II)	18.5/15 kW (25/20 HP)	118/71.6 N·m (87/52.8 lbf·ft)	
	8,000 rpm (High-torque)	15/11 kW (20/15 HP)	286/143 N·m (210.9/105.5 lbf·ft)	
	12,000 rpm	18.5/11 kW (25/15 HP)	118/52.5 N·m (87/38.7 lbf·ft)	
	15,000 rpm	18.5/11 kW (25/15 HP)	118/52.5 N·m (87/38.7 lbf·ft)	
SIEMENS	12,000 rpm	16.2/8.5 kW (21.7/11.4 HP)	119.7/63 N·m (88.3/46.5 lbf·ft)	
HEIDENHAIN	12,000 rpm	17/10 kW (22.8/13.4 HP)	108.6/63.7 N·m (80/47 lbf·ft)	

## KF5600/50 II | KF6700/50 II Spindle Specifications

PC	Speed r/min	Motor (Max./Cont.)	Torque (Max./Cont.)	Type
H/W FAHUC SMART PLUS	8,000 rpm	22/11 kW (30/15 HP)	353.2/143.2 N·m (260.5/105.6 lbf·ft)	Direct

# HIGH-PERFORMANCE, HIGH-PRECISION SPINDLE

## SPINDLE

### Direct Driven Spindle

The directly coupled spindle at a maximum revolution of 15,000rpm, allows high-speed processing. Additionally, the large diameter and the thickness of the spindle add to the stability of the machine.

(KF5600/50 II, KF6700/50 II : 8,000rpm)

### Spindle Cooling (Over 10,000 rpm / BT50 : 8,000 rpm Std.)

The spindle cooling system minimizes thermal displacement which can happen during lengthy machining operations, and offers continued accuracy based on the thermal stability.

❖ Improved cooling capability with chilling through head frame

### Through Spindle Coolant (20/30/70 bar) **OPTION**

Through Spindle Coolant is exceedingly useful when drilling deep holes. It helps increase the lifetime of the tool, while decreasing cycle time.

The improved quality of rotary joint prevents oil leakage.

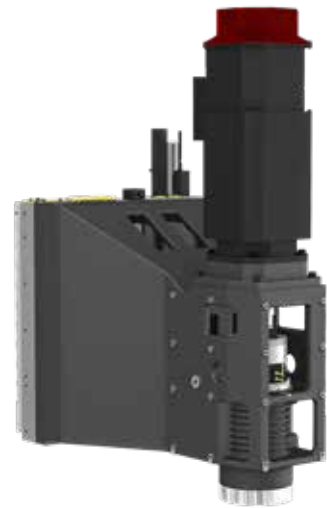

### Dual Contact Spindle

The Big Plus spindle system (BBT40) provides dual contact between the spindle face and the flange face of the tool holder.

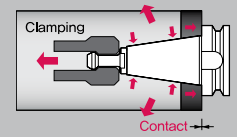

❖ Direct Spindle - Hybrid Tool Lock : Reducing heat and noise by removing the hydraulic motor

## HSK TOOL HOLDER

**OPTION**

HSK tool holder is utilized for precise positioning with less expansion in the spindle taper during high speed rotation. This ensures an excellent level of precision for die mold machining.



HSK Tool

# 04 ATC & MAGAZINE

High Productivity Achieved with High Rigidity, Accuracy Machining

## ATC & Magazine

[ ] : Option

Model	No. of Tools	Max. Tool Length	Max. Tool Dia. (W.T/W.O)	Max. Tool Weight	Tool Shank
KF4600 II	30 [40] EA	300 mm (11.8")	30T : $\varnothing 80/125$ mm ( $\varnothing 3.1"/\varnothing 4.9"$ ) [40, 60T : $\varnothing 76/125$ mm ( $\varnothing 3"/\varnothing 4.9"$ )]	8 kg (18 lb)	BBT40 [HSK-A63]
KF5600 II	30 [40, 60] EA				
KF6700 II	30 [40] EA				
KF5600L II	30 [40] EA	350 mm (13.8")	$\varnothing 125/\varnothing 250$ mm	15 kg (33 lb)	BBT50 [HSK-A100]
KF5600/50 II	24 EA				
KF6700/50 II	24 [30] EA				

# HIGH RIGIDITY, TOOL CHANGE SYSTEM

## ATC & MAGAZINE

### High Speed ATC

Position control through twin arm ATC on servo motors has been improved drastically. In addition, tool exchanging has become easier, reducing specific cutting time tremendously.

Position control on the Twin Arm ATC has improved drastically. The twin arm ATC enables faster tool change and increased productivity.



### Tool Change Time (C-C)

KF4600 II : 3.2 sec      KF5600 II : 3.2 sec      KF5600L II | KF6700 II : 3.5 sec

(KF5600/50 II | KF6700/50 II : 5.5 sec)

### Magazine

The tool magazine holds **30 tools** as standard and **60 tools** as an option. Due to the wider selection of tools and the random tool selection method, tool change time has improved.

(KF4600 II / KF5600L II : Opt. 40 tools)

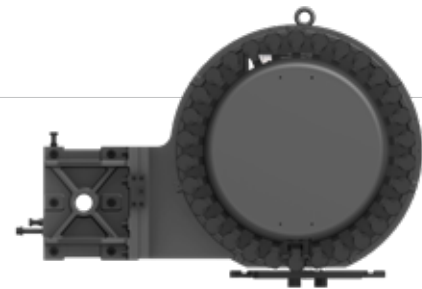

[Fixed : Option]

## BBT50 ATC & MAGAZINE

### BBT50 (KF5600/50 II | KF6700/50 II)

KF5600/50 II, KF6700/50 II provides a tool magazine of 24 tools as standard.

Also, ATC with high precision CAM provides fast and accurate tool change, reducing non-cutting time.

(KF6700/50 II : Opt. 30EA)

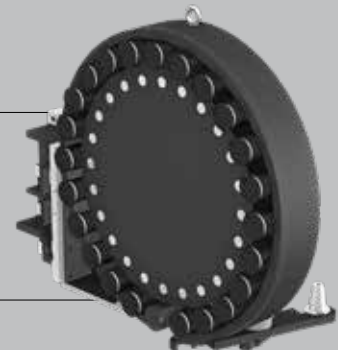

# 05 USER CONVENIENCE

Various Devices for User Friendly

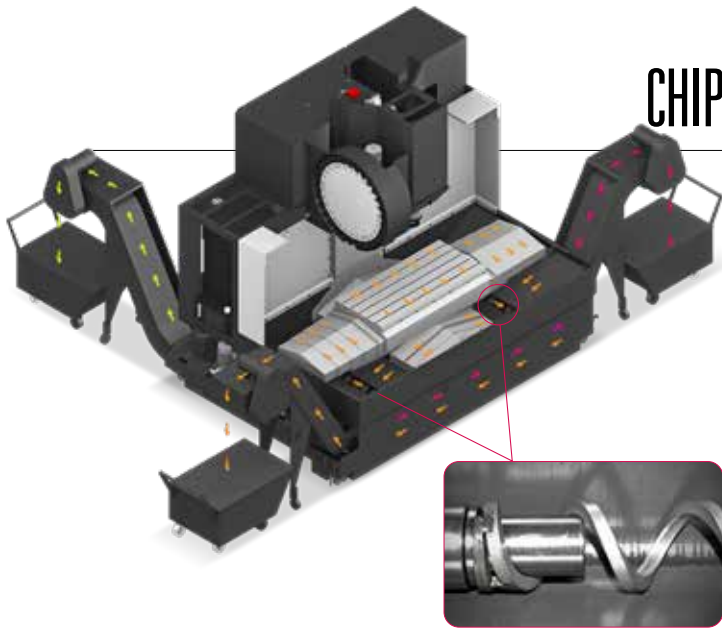

## CHIP DISPOSAL SOLUTION & COOLANT UNIT



Cutting Air Blow (Opt.)



Bed Flushing Coolant (Opt.)



Gun Coolant (Opt.)



Air Gun (Opt.)

### Interior Screw Chip Conveyor (Forward / Backward Rotation Function)

Dual screw type chip conveyors are located at each side of the bed which makes it convenient to remove chips. The interior screw and the chip conveyor operate at the same time and can be controlled separately at the time of prior consultation.

(Three screws for rear-type conveyor: 2 sides + 1 front)

Furthermore, chip disposal capability significantly has been improved due to optional bed-flushing coolant.

### Upper-type Conveyor (Std.)

The upper type chip conveyor is applied as a standard to efficiently remove chips generated during machining. In addition, the 365 liter (KF5600II, 6700II) of large coolant tank provides a seamless machining environment even with large amounts of coolant.

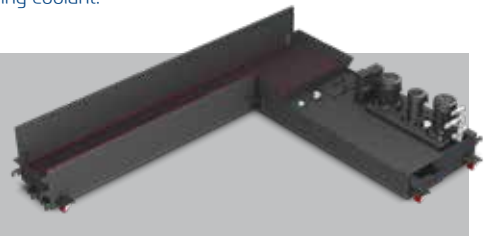

Hinge	Chip Type : Roughing Chip, Long Chip, Chip complex	Material : SS41, 45C, Cast Steel	Side/Rear Direction
	Highly efficient when disposing a lot of chips. Capable of handling stringy chips..		
Scraper	Chip Type : Finely broken chip blown out	Material : cast Iron, Nonferrous	
	Convenient for shortly cut chips.		
❖ Screw	Chip Type : The lower portion of micro-chips	Material : Steel, Casting	
	Compresses and ejects chips to reduce chip Trouble.		
❖ Drum Filter	Chip Type : Powder, Micro Chip	Material : AL	
	Advantageous in precision, as the chips do not flow in to the coolant nozzle.		

❖ When ordering a screw or drum filter chip conveyor, prior consult with hyundai wia's sales person.

## PRECISION SYSTEM



### Linear Scale

Linear scales increase positioning accuracy and reduce distortion caused by thermal growth, thus ensuring a more accurate finished part



### Touch Sensor

Workpiece coordinate values can be set automatically using the optional spindle probe.



### TLM (Laser & Touch)

Tool lengths and diameters can be set automatically using the optional tool setter. This can also be used to monitor attrition and detect broken tools.

## ECO SYSTEM



### Oil-skimmer

Separated oil-skimmer and coolant tank to keep coolant free of tramp oils.



### Automatic Grease Supply Unit

Optional automatic grease lubrication eliminates the need for an oil skimmer and significantly reduces maintenance costs against oil lubrication.



### MQL (Minimal Quantity Lubrication)

The goal of this system is to spray only the amount of lubricant required to prevent heat and chip build up at the cutting tool or work piece face.



## NC ROTARY TABLE & HYDRAULIC SUPPLY UNIT

Various shapes of products can be processed when using NC Rotary Table. In addition, 100 bar of high pressure hydraulic unit for the fixture increases the tightening power of the teeth.

# 06 HYUNDAI WIA FANUC – SMART PLUS

The Compatible All-round Control



**15" Touch-type Monitor as a standard**

Smart Machine Control	Fast Cycle Time Technology
Conversational Program	Fine Surface Technology
i-HMI	Smart Guide-i
AI Contour Control	Machining-aid Function
Smooth Tolerance Control	AICC-2 (200 blocks)
JERK Control	0.1µm command and specify tolerance
Machining Condition Selection	Diminished vibration by controlling acceleration speed
Machining Quality Control Function	Designated machining level based on speed & quality
Part Program Storage	Smooth Tolerance+ integrated support
No. of Registerable Programs	5120M (2MB)
	1000 EA

## ACAM (Automatic CAM)

Cloud-based automatic CAM S/W that automatically creates NC programs only by inputting drawing files

Cloud-based Intelligent Programming

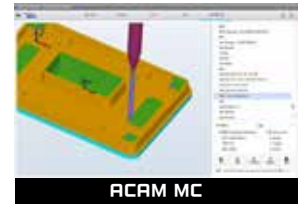
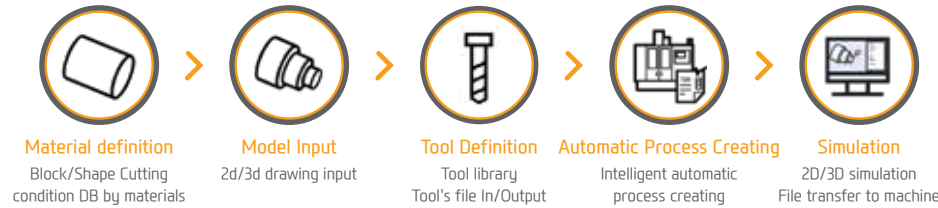

## MMS (Machine Monitoring System)



### 1. MMS Cloud

A cloud server-based equipment monitoring system for collecting and analyzing facility operation data.

### 2. MMS Edge

A client server-based tool monitoring system for collection/analysis of facility operation data. (Compatible with client MES / ERP interface)

## SMART CNC (FANUC SMART PLUS)



### 1. Dialogue Program (Smart Guide-i)

This software offers the maximum user convenience through dialogue manipulation from setup to processing. This includes writing processing programs and simulation checks.

### 2. LAUNCHER

This software offers shortcuts for quick access to specialized features and frequently used features.

# SPECIFICATIONS

## Spindle Output/Torque Diagram

### Direct 8,000rpm (KF4600II/5600II)

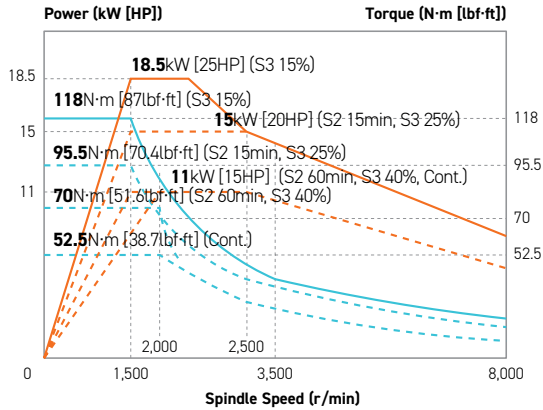

### Direct 8,000rpm (KF6700II)

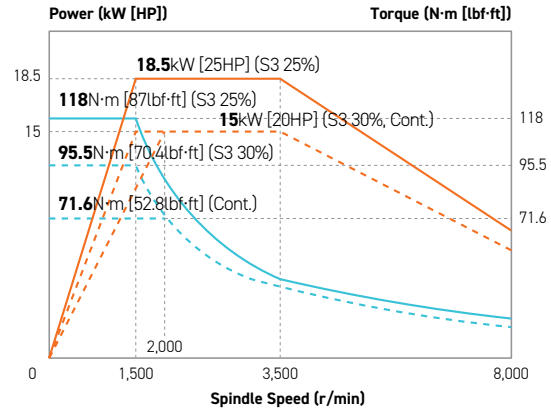

### Direct 8,000rpm (High-Torque)

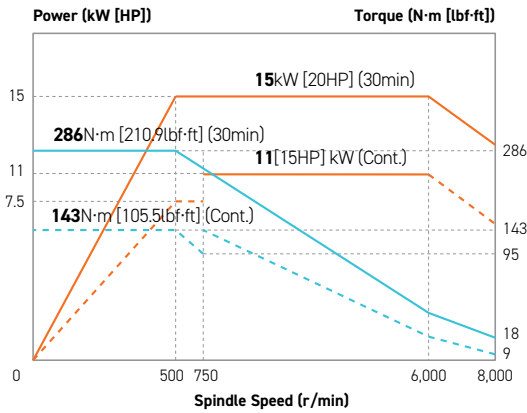

### Direct 10,000rpm

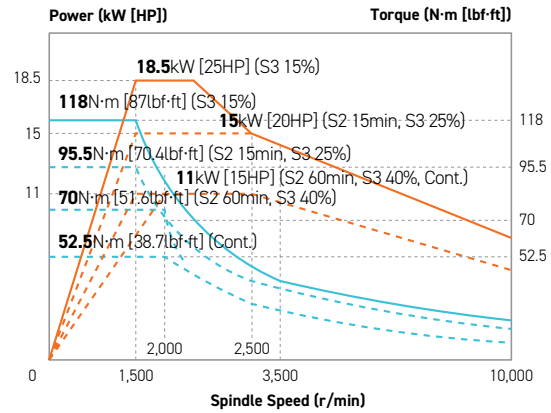

### Direct 12,000rpm

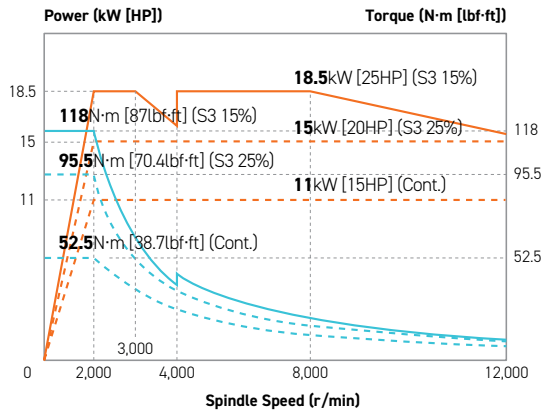

### Direct 15,000rpm

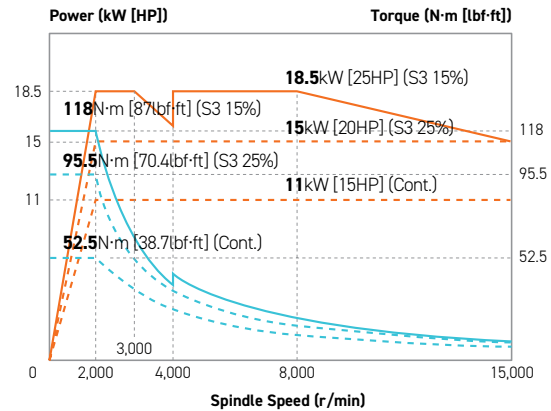

# SPECIFICATIONS

## Spindle Output/Torque Diagram

### SIEMENS Direct 12,000rpm

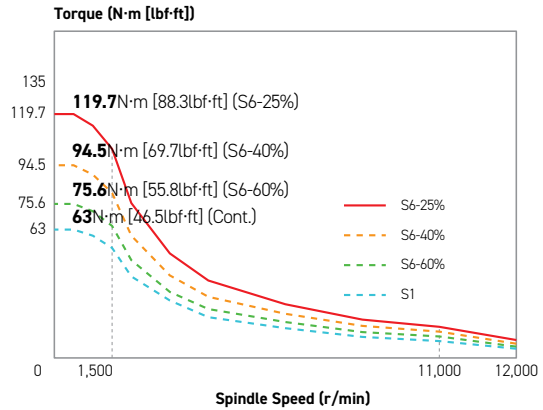
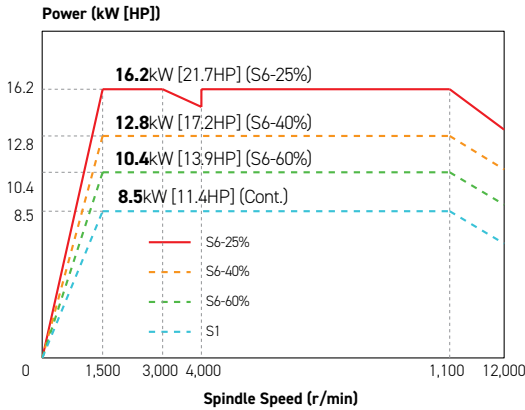

### HEIDENHAIN Direct 12,000rpm

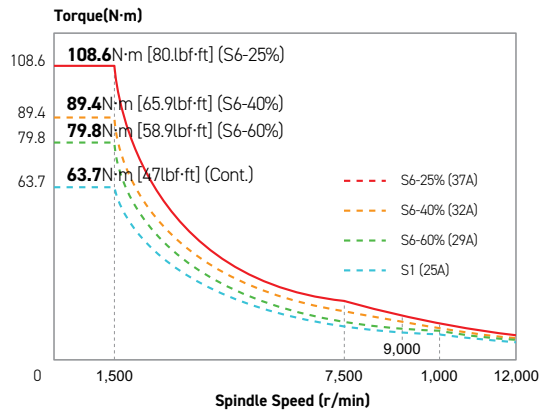
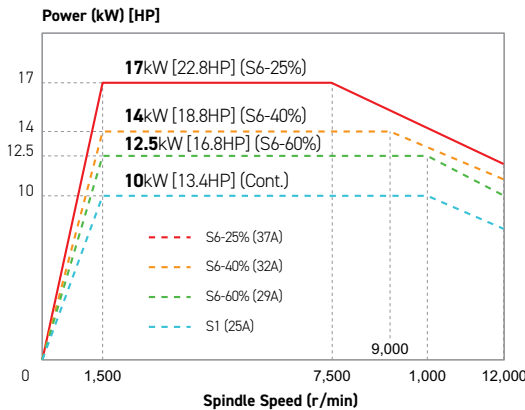

### KF5600/50 II | KF6700/50 II Direct 8,000rpm

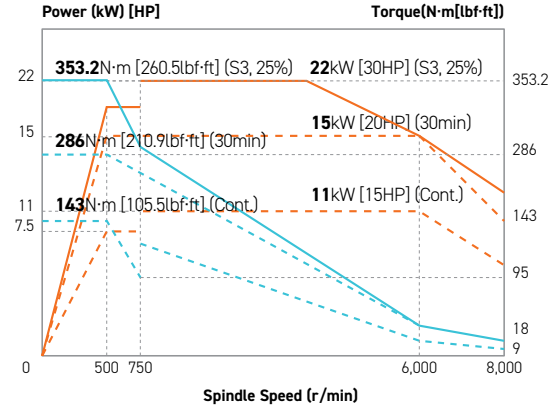

# SPECIFICATIONS

## Standard & Optional

● : Standard ○ : Option ☆ : Prior Consultation - : Non Applicable

Spindle		KF4600 II
8,000rpm	FANUC	●
8,000rpm (High-torque)	FANUC	○
10,000rpm	FANUC	○
12,000rpm	FANUC	○
15,000rpm	FANUC	○
12,000rpm	SIEMENS	○
12,000rpm	HEIDENHAIN	○
Spindle Cooling System	8,000rpm	○
	Over 10,000rpm	●
ATC		
ATC Extension	30	●
	40	○
Tool Shank Type	BBT40	●
	HSK-A63 (12K, 15K)	○
	CAT40/BCV40	○
U-Center	D'andrea	○
Pull Stud	45°	●
Table & Column		
T-Slot Table		●
NCRotary Table		☆
High Column	200mm (7.9")	○
	300mm (11.8")	-
Coolant System		
Std. Coolant (Main Spindle Nozzle)		●
	20bar	○
	30bar, 20 ℓ	○
	70bar, 15 ℓ	○
	70bar, 30 ℓ	○
Through Spindle Coolant		○
	20bar	○
	30bar, 20 ℓ	○
	70bar, 15 ℓ	○
	70bar, 30 ℓ	○
Top Cover		●
Shower Coolant		○
Gun Coolant		○
Bed Flushing Coolant		○
Air Gun		○
Cutting Air Blow		○
Tool Measuring Air Blow (Only for TLM)		○
Air Blow for Automation		☆
Thru MQL Device (Without MQL)		☆
Coolant Chiller (Sub Tank)		☆
Power Coolant System (For Automation)		☆
Chip Disposal		
Coolant Tank	340	●
Interior Screw Chip Conveyor		●
Upper Chip Conveyor (Hinge)	Left	○
	Right	○
Flood Chip Conveyor (Hinge/Scraper)	Left	○
	Right	○
	Rear	○
Screw Type Chip Conveyor	Left	☆
	Right	☆
Drum Filter Type Chip Conveyor	Left	☆
	Right	☆
	Rear	☆
Chip Wagon	Standard(180 ℓ)	○
	Swing(200 ℓ)	○
	Large Swing(290 ℓ)	○
	Large Size(330 ℓ)	○
	Customized	☆
*Special Option		
ATC Auto Shutter	30T/40T	○
ATC Full Cover	30T/40T/60T	○
*Fine Dust Protecting Package		
Table Around Cover	Wet Machining	○
Bellows Cover (X/Y)		○
Multi Cover (Z)	Dry Machining	○
Guide Way Double Wiper		○
ETC		
Tool Box		●
Customized Color	Need for Munsel No.	☆
CAD&CAM Software		☆

Electric Device		KF4600 II
Call Light	1 Color : ●	●
Call Light & Buzzer	3 Color : ● ● ● B	○
Electric Cabinet Light		○
Remote MPG		●
3 Axis MPG		○
Work Counter	Digital	○
Total Counter	Digital	○
Tool Counter	Digital	○
Multi Tool Counter	Digital	☆
Electric Circuit Breaker	FANUC	○
	SIEMENS	-
AVR (Auto Voltage Regulator)		☆
Transformer	30kVA	○
	35kVA	-
Auto Power Off		○
Back up Module for Black out		○
Measuring Device		
Air Zero	TACO	○
	SMC	○
Work Measuring Device		○
TLM	Touch	○
	Laser	○
(Marposs/Renishaw/Blum)		○
Tool Broken Detective Device		☆
Linear Scale	X/Y/Z Axis	○
Coolant Level Sensor (Only for Chip Conveyor, Bladder Type)		☆
Environment		
Air Conditioner		○
Oil Mist Collector		☆
Oil Skimmer (Only for Chip Conveyor)		○
MQL (Minimal Quantity Lubrication)		☆
Fixture & Automation		
Auto Door	Std.	○
	High Speed	☆
Auto Shutter (Only for Automatic System)		○
Sub O/P		☆
NC Rotary Table/F	Single	○
	Channel	☆
Control of Additional Axis	1Axis	○
	2Axis	☆
External M Code dea		○
Automation Interface		☆
I/O Extension (In & Out)	16 Contact	☆
	32 Contact	☆
Hyd. Device		
Hyd. Unit for Fixture	45bar	-
	70bar	○
	100bar	○
	Customized	☆
S/W		
Automatic CAM (HW-ACAM)		-
Dialogue Program (HW-DPRO)		○
DNC software (HW-eDNC)		○
Machine Monitoring System (HW-MMS Cloud)		☆
Machine Monitoring System & Analysis (Customer Installation : HW-MMS Edge)		☆
Smart Guide-i : FANUC		●
Smart S/W		☆

\* Detailed options require consultation with HYUNDAI WIA

Specifications are subject to change without notice for improvement. / Please refer to the S/W catalog (iRIS) for details by S/W product.

# SPECIFICATIONS

## Standard & Optional

● : Standard ○ : Option ☆ : Prior Consultation - : Non Applicable

		KF5600 II	KF5600L II
<b>Spindle</b>			
8,000rpm	FANUC	●	
8,000rpm (High-torque)	FANUC	○	
10,000rpm	FANUC	○	
12,000rpm	FANUC	○	
15,000rpm	FANUC	○	
12,000rpm	SIEMENS	○	
12,000rpm	HEIDENHAIN	○	
Spindle Cooling System	8,000rpm	○	
	Over 10,000rpm	●	
<b>ATC</b>			
ATC Extension	30	●	
	40	○	
	60	○	
Tool Shank Type	BBT40	●	
	HSK-A63 (12K, 15K)	○	
	CAT40/BCV40	○	
U-Center	D'andrea	○	
Pull Stud	45°	●	
<b>Table &amp; Column</b>			
T-Slot Table		●	
NCRotary Table		☆	
High Column	200mm (7.9")		-
	300mm (11.8")	○	○ (60T : -)
<b>Coolant System</b>			
Std. Coolant (Main Spindle Nozzle)		●	
Through Spindle Coolant	20bar	○	
	30bar, 20 ℓ	○	
	70bar, 15 ℓ	○	
	70bar, 30 ℓ	○	
Top Cover		●	
Shower Coolant		○	
Gun Coolant		○	
Bed Flushing Coolant		○	
Air Gun		○	
Cutting Air Blow		○	
Tool Measuring Air Blow (Only for TLM)		○	
Air Blow for Automation		☆	
Thru MQL Device (Without MQL)		☆	
Coolant Chiller (Sub Tank)		☆	
Power Coolant System (For Automation)		☆	
<b>Chip Disposal</b>			
Coolant Tank	350 ℓ	●	-
	370 ℓ	-	●
Interior Screw Chip Conveyor		●	
Upper Chip Conveyor (Hinge)	Left	○	
	Right	○	
Flood Chip Conveyor (Hinge/Scraper)	Left	○	
	Right	○	
	Rear	○	
Screw Type Chip Conveyor	Left	☆	
	Right	☆	
Drum Filter Type Chip Conveyor	Left	☆	
	Right	☆	
Chip Wagon	Rear	☆	
	Standard(180 ℓ)	○	
	Swing(200 ℓ)	○	
	Large Swing(290 ℓ)	○	
	Large Size(330 ℓ)	○	
	Customized	☆	
<b>*Special Option</b>			
ATC Auto Shutter	30T/40T	○	-
ATC Full Cover	30T/40T/60T	○	-
<b>*Fine Dust Protecting Package</b>			
Table Around Cover	Wet Machining	○	-
Bellows Cover (X/Y)		○	-
Multi Cover (Z)	Dry Machining	○	-
Guide Way Double Wiper		○	-
<b>ETC</b>			
Tool Box		●	
Customized Color	Need for Munsel No.	☆	
CAD&CAM Software		☆	

		KF5600 II	KF5600L II
<b>Electric Device</b>			
Call Light	1 Color : ●		●
Call Light & Buzzer	3 Color : ● ● ● B		○
Electric Cabinet Light			○
Remote MPG		●	
3 Axis MPG		○	
Work Counter	Digital		○
Total Counter	Digital		○
Tool Counter	Digital		○
Multi Tool Counter	Digital		☆
Electric Circuit Breaker	FANUC		○
	SIEMENS		-
AVR (Auto Voltage Regulator)			☆
Transformer	30kVA		○
	35kVA		-
Auto Power Off			○
Back up Module for Black out			○
<b>Measuring Device</b>			
Air Zero	TACO		○
	SMC		○
Work Measuring Device			○
TLM (Marposh/Renishaw/Blum)	Touch		○
	Laser		○
Tool Broken Detective Device			☆
Linear Scale	X/Y/Z Axis		○
Coolant Level Sensor (Only for Chip Conveyor, Bladder Type)			☆
<b>Environment</b>			
Air Conditioner			○
Oil Mist Collector			☆
Oil Skimmer (Only for Chip Conveyor)			○
MQL (Minimal Quantity Lubrication)			☆
<b>Fixture &amp; Automation</b>			
Auto Door	Std.		○
	High Speed		☆
Auto Shutter (Only for Automatic System)			○
Sub O/P			☆
NC Rotary Table/F	Single		○
	Channel		☆
Control of Additional Axis	1Axis		○
	2Axis		☆
External M Code 4ea			○
Automation Interface			☆
I/O Extension (In & Out)	16 Contact		☆
	32 Contact		☆
<b>Hyd. Device</b>			
Hyd. Unit for Fixture	45bar		-
	70bar		○
	100bar		○
	Customized		☆
<b>S/W</b>			
Automatic CAM (HW-ACAM)			-
Dialogue Program (HW-DPRO)			○
DNIC software (HW-eDNIC)			○
Machine Monitoring System (HW-MMS Cloud)			☆
Machine Monitoring System & Analysis (Customer Installation : HW-MMS Edge)			☆
Smart Guide-i : FANUC			●
Smart S/W			☆

\* Detailed options require consultation with HYUNDAI WIA.

Specifications are subject to change without notice for improvement. / Please refer to the S/W catalog (iRS) for details by S/W product.

# SPECIFICATIONS

## Standard & Optional

● : Standard ○ : Option ☆ : Prior Consultation - : Non Applicable

Spindle		KF6700 II
8,000rpm	FANUC	●
8,000rpm (High-torque)	FANUC	○
10,000rpm	FANUC	○
12,000rpm	FANUC	○
15,000rpm	FANUC	○
12,000rpm	SIEMENS	○
12,000rpm	HEIDENHAIN	○
Spindle Cooling System	8,000rpm	○
	Over 10,000rpm	●
ATC		
ATC Extension	30	●
	40	○
	60	○
Tool Shank Type	BBT40	●
	HSK-A63 (12K, 15K)	○
	CAT40/BVC40	○
U-Center	D'andrea	○
Pull Stud	45°	●
Table & Column		
T-Slot Table		●
NCRotary Table		☆
High Column	200mm (7.9")	-
	300mm (11.8")	○
Coolant System		
Std. Coolant (Main Spindle Nozzle)	20bar	○
	30bar, 20 ℓ	○
	70bar, 15 ℓ	○
	70bar, 30 ℓ	○
Through Spindle Coolant		○
Top Cover		●
Shower Coolant		○
Gun Coolant		○
Bed Flushing Coolant		○
Air Gun		○
Cutting Air Blow		○
Tool Measuring Air Blow (Only for TLM)		○
Air Blow for Automation		☆
Thru MQL Device (Without MQL)		☆
Coolant Chiller (Sub Tank)		☆
Power Coolant System (For Automation)		☆
Chip Disposal		
Coolant Tank	370 ℓ	●
Interior Screw Chip Conveyor		●
Upper Chip Conveyor (Hinge)	Left	○
	Right	○
Flood Chip Conveyor (Hinge/Scraper)	Left	○
	Right	○
	Rear	○
Screw Type Chip Conveyor	Left	☆
	Right	☆
Drum Filter Type Chip Conveyor	Left	☆
	Right	☆
	Rear	☆
Chip Wagon	Standard(180 ℓ)	○
	Swing(200 ℓ)	○
	Large Swing(290 ℓ)	○
	Large Size(330 ℓ)	○
Customized		☆
*Special Option		
ATC Auto Shutter	30T/40T	○
ATC Full Cover	30T/40T/60T	○
*Fine Dust Protecting Package		
Table Around Cover	Wet Machining	○
Bellows Cover (X/Y)		○
Multi Cover (Z)	Dry Machining	○
Guide Way Double Wiper		○
ETC		
Tool Box		●
Customized Color	Need for Munsel No.	☆
CAD&CAM Software		☆

Electric Device		KF6700 II
Call Light	1 Color : ●	●
Call Light & Buzzer	3 Color : ● ● ● B	○
Electric Cabinet Light		○
Remote MPG		●
3 Axis MPG		○
Work Counter	Digital	○
Total Counter	Digital	○
Tool Counter	Digital	○
Multi Tool Counter	Digital	☆
Electric Circuit Breaker	FANUC	○
	SIEMENS	-
AVR (Auto Voltage Regulator)		☆
Transformer	30kVA	○
	35kVA	-
Auto Power Off		○
Back up Module for Black out		○
Measuring Device		
Air Zero	TACO	○
	SMC	○
Work Measuring Device		○
TLM (Marposs/Renishaw/Blum)	Touch	○
	Laser	○
Tool Broken Detective Device		☆
Linear Scale	X/Y/Z Axis	○
Coolant Level Sensor (Only for Chip Conveyor, Bladder Type)		☆
Environment		
Air Conditioner		○
Oil Mist Collector		☆
Oil Skimmer (Only for Chip Conveyor)		○
MQL (Minimal Quantity Lubrication)		☆
Fixture & Automation		
Auto Door	Std.	○
	High Speed	☆
Auto Shutter (Only for Automatic System)		○
Sub O/P		☆
NC Rotary Table/F	Single	○
	Channel	☆
Control of Additional Axis	1Axis	○
	2Axis	☆
External M Code dea		○
Automation Interface		☆
I/O Extension (In & Out)	16 Contact	☆
	32 Contact	☆
Hyd. Device		
Hyd. Unit for Fixture	45bar	-
	70bar	○
	100bar	○
	Customized	☆
S/W		
Automatic CAM (HW-ACAM)		-
Dialogue Program (HW-DPRO)		○
DNC software (HW-eDNC)		○
Machine Monitoring System (HW-MMS Cloud)		☆
Machine Monitoring System & Analysis (Customer Installation : HW-MMS Edge)		☆
Smart Guide-i : FANUC		●
Smart S/W		☆

\* Detailed options require consultation with HYUNDAI WIA

Specifications are subject to change without notice for improvement. / Please refer to the S/W catalog (iRIS) for details by S/W product.

# SPECIFICATIONS

## Standard & Optional

● : Standard ○ : Option ☆ : Prior Consultation - : Non Applicable

		KF5600/50 II	KF6700/50 II
<b>Spindle</b>			
8,000rpm		●	
Spindle Cooling System		●	
<b>ATC</b>			
ATC Extension	24	●	
	30	-	○
Tool Shank Type	BBT50	●	
	HSK-A100	○	
	CAT50/BCV50	○	
U-Center	D'andrea	○	
Pull Stud	45°	●	
<b>Table &amp; Column</b>			
T-Slot Table		●	
NCRotary Table		☆	
High Column	300mm	○	
<b>클린트장치</b>			
Std. Coolant (Main Spindle Nozzle)		●	
Through Spindle Coolant	20bar	○	
	30bar, 20 ℓ	○	
	70bar, 15 ℓ	○	
	70bar, 30 ℓ	○	
Top Cover		●	
Shower Coolant		○	
Gun Coolant		○	
Bed Flushing Coolant		○	
Air Gun		○	
Cutting Air Blow		○	
Tool Measuring Air Blow (Only for TLM)		○	
Air Blow for Automation		☆	
Thru MQL Device (Without MQL)		☆	
Coolant Chiller (Sub Tank)		☆	
Power Coolant System (For Automation)		☆	
<b>Chip Disposal</b>			
Coolant Tank	350 ℓ	●	-
	370 ℓ	-	●
Interior Screw Chip Conveyor		●	
Upper Chip Conveyor (Hinge)	Left	○	
	Right	○	
Flood Chip Conveyor (Hinge/Scraper)	Left	-	
	Right	-	
	Rear	-	
Screw Type Chip Conveyor	Left	☆	
	Right	☆	
Drum Filter Type Chip Conveyor	Left	☆	
	Right	☆	
	Rear	☆	
Chip Wagon	Standard(180 ℓ)	○	
	Swing(200 ℓ)	○	
	Large Swing(290 ℓ)	○	
	Large Size(330 ℓ)	○	
	Customized	☆	
<b>ETC</b>			
Tool Box		●	
Customized Color	Need for Munsel No.	☆	
CAD&CAM Software		☆	

		KF5600/50 II	KF6700/50 II
<b>Electric Device</b>			
Call Light	1 Color : ●	●	
Call Light & Buzzer	3 Color : ● ● ● B	○	
Electric Cabinet Light		○	
Remote MPG		●	
3 Axis MPG		○	
Work Counter	Digital	○	
Total Counter	Digital	○	
Tool Counter	Digital	○	
Multi Tool Counter	Digital	☆	
Electric Circuit Breaker		○	
AVR (Auto Voltage Regulator)		☆	
Transformer	30kVA	○	
	35kVA	-	
Auto Power Off		○	
Back up Module for Black out		○	
<b>Measuring Device</b>			
Air Zero	TACO		☆
	SMC		☆
Work Measuring Device			○
TLM (Marposh/Renishaw/Blum)	Touch		○
	Laser		○
Tool Broken Detecting Device			○
Linear Scale		X/Y/Z Axis	○
Coolant Level Sensor (Only for Chip Conveyor, Bladder Type)			☆
<b>Environment</b>			
Air Conditioner			○
Oil Mist Collector			☆
Oil Skimmer (Only for Chip Conveyor)			○
MQL (Minimal Quantity Lubrication)			☆
<b>Fixture &amp; Automation</b>			
Auto Door	Std.		○
	High Speed		☆
Auto Shutter (Only for Automatic System)			○
Sub O/P			☆
NC Rotary Table/F	Single		☆
	Channel		☆
Control of Additional Axis	1Axis		○
	2Axis		☆
External M Code 4ea			○
Automation Interface			☆
I/O Extension (In & Out)	16 Contact		☆
	32 Contact		☆
<b>Hyd. Device</b>			
Hyd. Unit for Fixture	45bar		-
	70bar		○
	100bar		○
	Customized		☆
<b>S/W</b>			
Automatic CAM (HW-ACAM)			-
Dialogue Program (HW-DPRO)			○
DNC software (HW-eDNC)			○
Machine Monitoring System (HW-MMS Cloud)			☆
Machine Monitoring System & Analysis (Customer Installation : HW-MMS Edge)			☆
Smart Guide-i : FANUC			●
Smart S/W			☆

# SPECIFICATIONS

## External Dimensions

unit : mm(in)

### KF4600 II

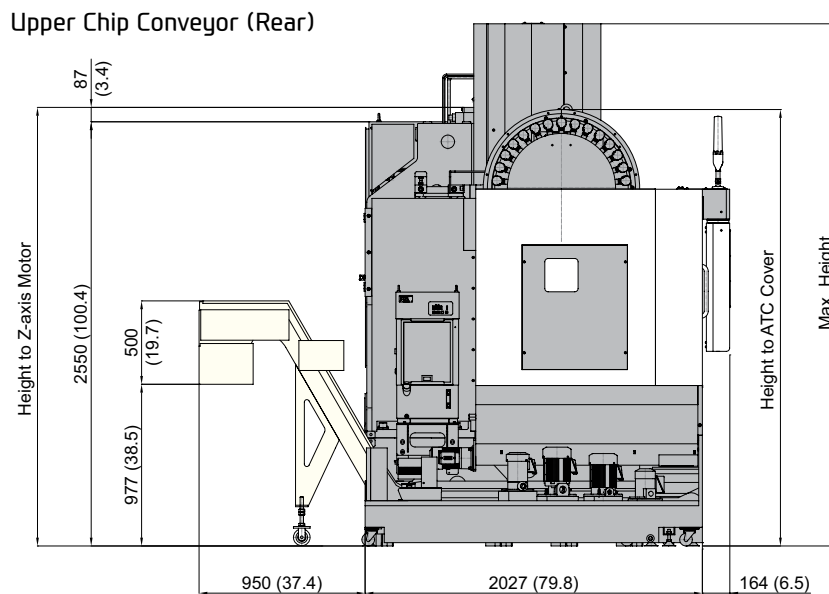
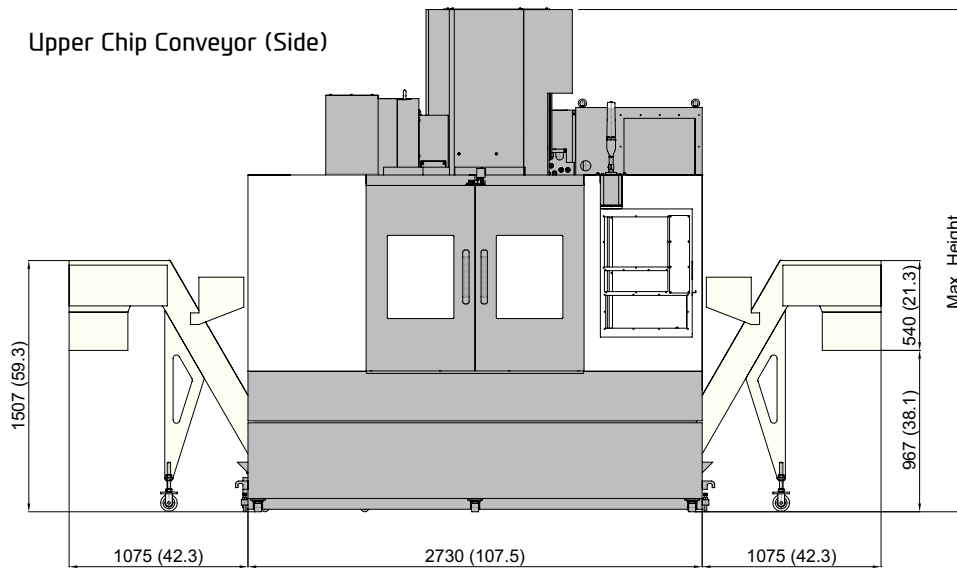

\*Level Block Height : Upper Chip Conveyor (Side)\_80mm (3.1"), Upper Chip Conveyor (Rear)\_200mm (7.9")

ITEM	Max. Height		30T ATC Cover		40T ATC Cover		Z-axis Motor	
	Std.	H/Column	Std.	H/Column	Std.	H/Column	Std.	H/Column
Upper/Side	3,028 (119.2")	3,228 (127.1")	2,510 (98.8")	2,710 (106.7")	2,710 (106.7")	2,910 (114.6")	2,740 (107.9")	2,940 (115.7")
Upper/Rear	3,148 (123.9")	3,348 (131.8")	2,630 (103.5")	2,830 (111.4")	2,830 (111.4")	3,030 (119.3")	2,860 (112.6")	3,060 (120.5")

# SPECIFICATIONS

## External Dimensions

unit : mm(in)

### KF5600 II

Upper Chip Conveyor (Side)

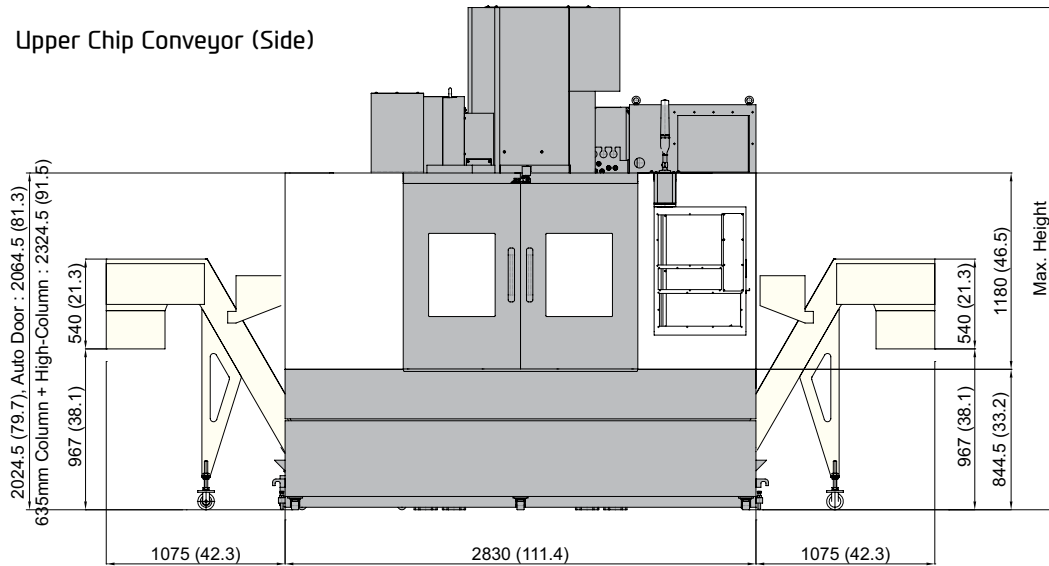

Upper Chip Conveyor (Rear)

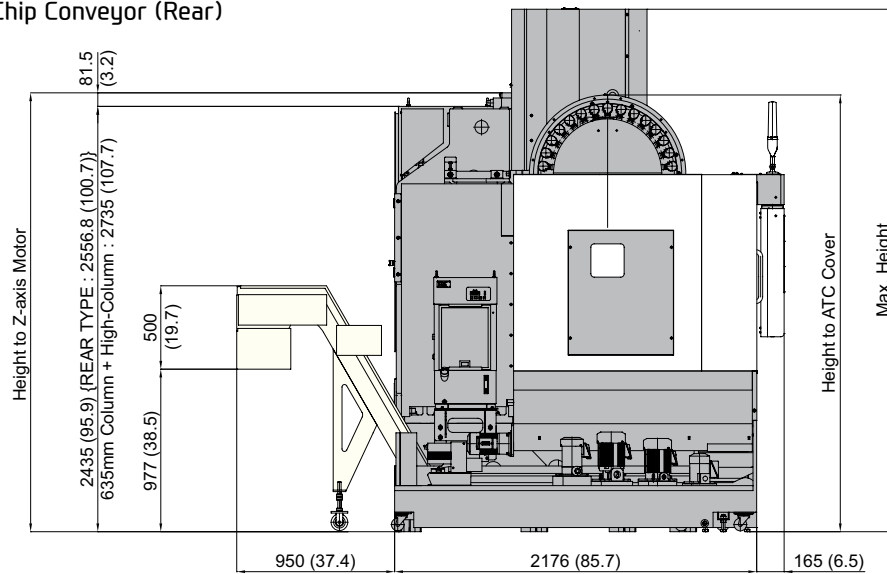

\*Level Block Height : Upper Chip Conveyor (Side)\_80mm (3.1"), Upper Chip Conveyor (Rear)\_200mm (7.9")

ITEM	Max. Height		30T ATC Cover			40T ATC Cover			60T ATC Cover			Z-axis Motor		
	Std.	H/C	Std.	635mm /C	H/C	Std.	635mm /C	H/C	Std.	635mm /C	H/C	Std.	635mm /C	H/C
Upper/ Side	3,028 (119.2")	3,443 (135.6")	2,510 (98.8")	2,627 (103.4")	2,926 (115.2")	2,710 (106.7")	2,828 (111.3")	3,126 (123.1")	2,380 (93.7")	2,495 (98.2")	2,680 (105.5")	2,740 (107.9")	2,855 (112.4")	3,155 (124.2")
Upper/ Rear	3,148 (123.9")	3,563 (140.3")	2,630 (103.5")	2,748 (108.2")	3,046 (119.9")	2,830 (111.4")	2,948 (116.1")	3,246 (127.8")	2,500 (98.4")	2,615 (103")	2,800 (110.2")	2,860 (112.6")	2,975 (117.1")	3,275 (128.9")

# SPECIFICATIONS

## External Dimensions

unit : mm(in)

### KF6700 II

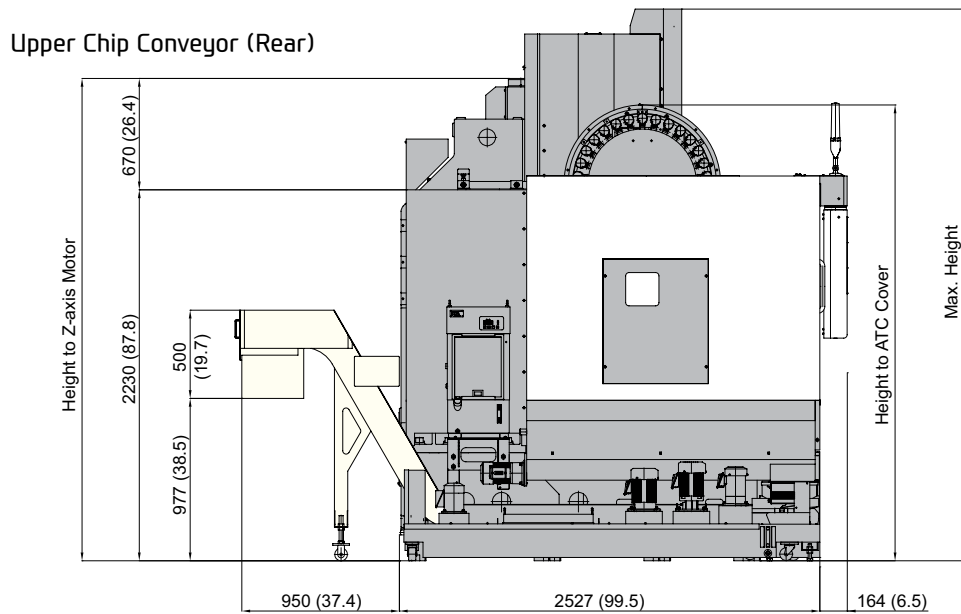
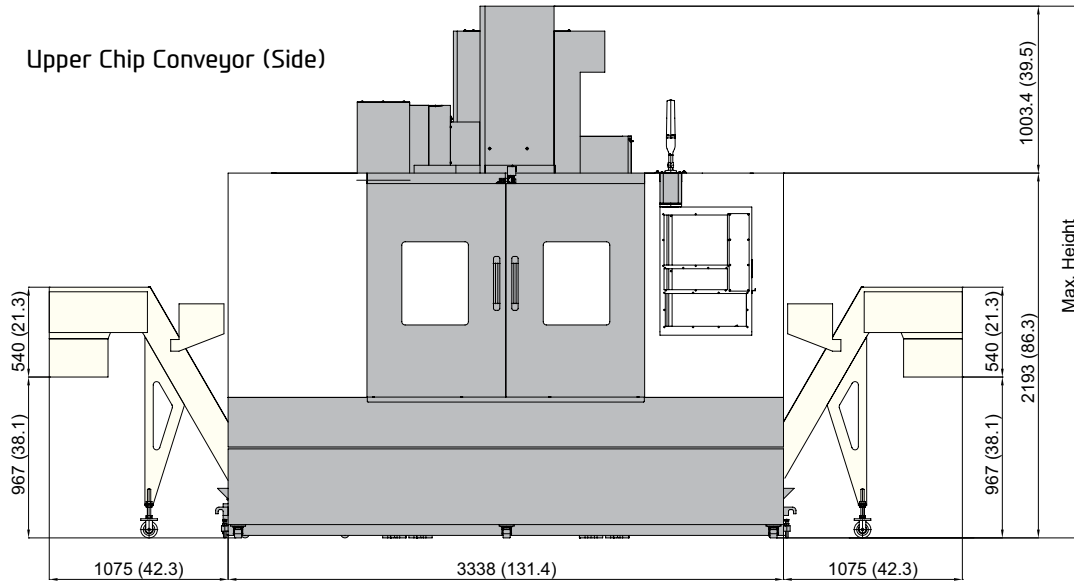

\*Level Block Height : Upper Chip Conveyor (Side)\_80mm (3.1"), Upper Chip Conveyor (Rear)\_200mm (7.9")

ITEM	Max. Height		30T ATC Cover		40T ATC Cover		60T ATC Cover		Z-axis Motor	
	Std.	H/Column	Std.	H/Column	Std.	H/Column	Std.	H/Column	Std.	H/Column
Upper/ Side	3,196 (125.8")	3,496 (137.6")	2,620 (103.1")	2,920 (115")	2,820 (111")	3,120 (122.8")	2,380 (93.7")	2,680 (105.5")	2,780 (109.4")	3,080 (121.3")
Upper/ Rear	3,316 (130.6")	3,616 (142.4")	2,740 (107.9")	3,040 (119.7")	2,940 (115.7")	3,240 (127.6")	2,500 (98.4")	2,800 (110.2")	2,900 (114.2")	3,200 (126")

# SPECIFICATIONS

## External Dimensions

unit : mm(in)

### KF5600L II

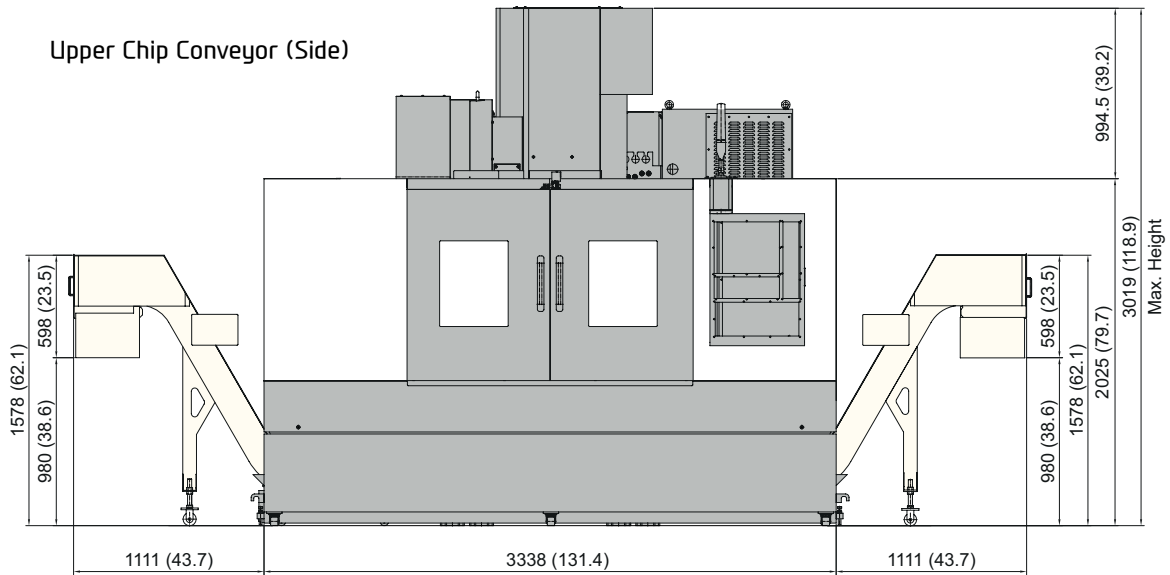

### Upper Chip Conveyor (Rear)

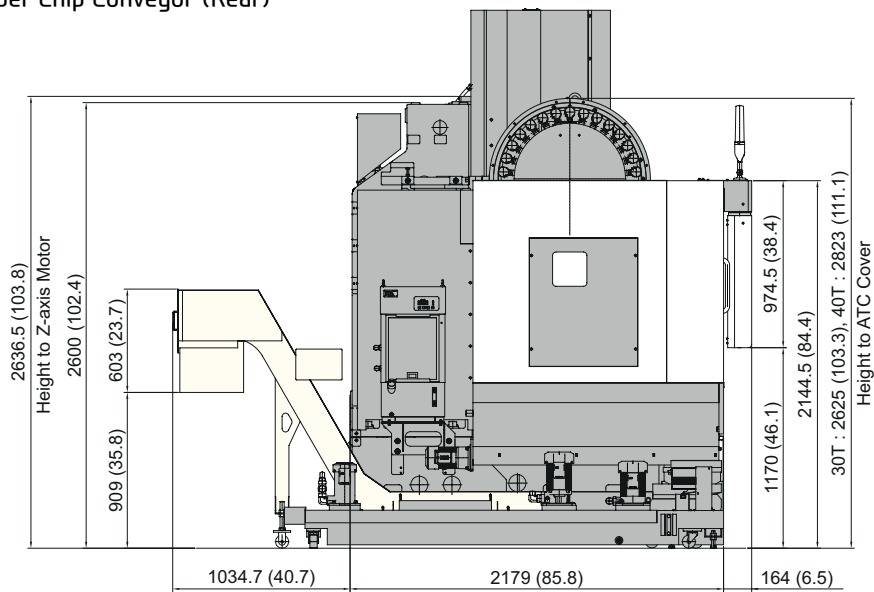

\*Level Block Height : Upper Chip Conveyor (Side)\_80mm (3.1"), Upper Chip Conveyor (Rear)\_200mm (7.9")

ITEM	Max. Height		30T ATC Cover		40T ATC Cover		Z-axis Motor	
	Std.	H/Column	Std.	H/Column	Std.	H/Column	Std.	H/Column
Upper/ Side	3,019 (118.9)	-	2,505 (98.6)	-	2,703 (106.4)	-	2,517 (99.1)	-
Upper/ Rear	3,139 (123.6)	-	2,625 (103.3)	-	2,823 (111.1)	-	2,636.5 (103.8)	-

# SPECIFICATIONS

## External Dimensions

unit : mm(in)

### KF5600/50 II

Upper Chip Conveyor (Side)

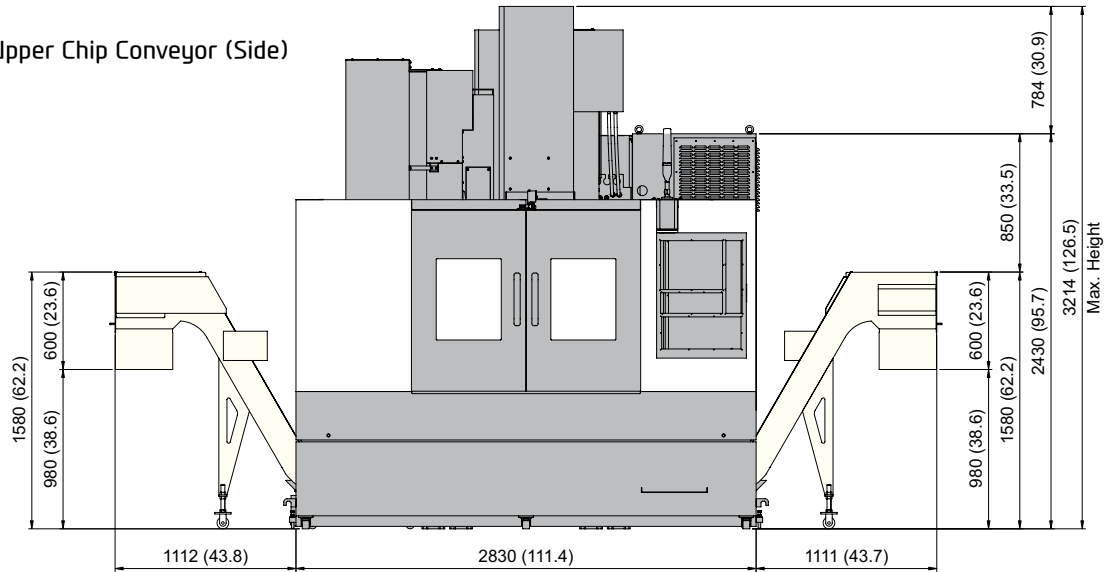

Upper Chip Conveyor (Rear)

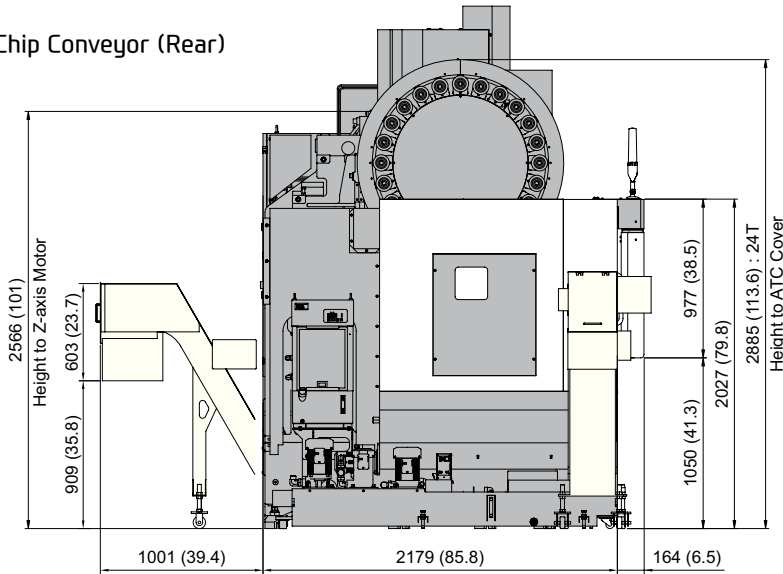

\*Level Block Height : Upper Chip Conveyor (Side) \_80mm (3.1"), Upper Chip Conveyor (Rear) \_200mm (7.9")

ITEM	Max. Height		24T ATC Cover			Z-axis Motor		
	Std.	H/Column	Std.	635mm/C	H/Column	Std.	635mm/C	H/Column
Upper/ Side	3,214 (126.5)	3,629 (142.9)	2,885 (113.6)	3,003 (118.2)	3,301 (130)	2,566 (101)	2,711 (106.7)	2,981 (117.4)
Upper/ Rear	3,334 (131.3)	3,749 (147.6)	3,005 (118.3)	3,123 (123)	3,421 (134.7)	2,686 (105.7)	2,831 (111.5)	3,101 (122.1)

# SPECIFICATIONS

## External Dimensions

unit : mm(in)

### KF6700/50 II

Upper Chip Conveyor (Side)

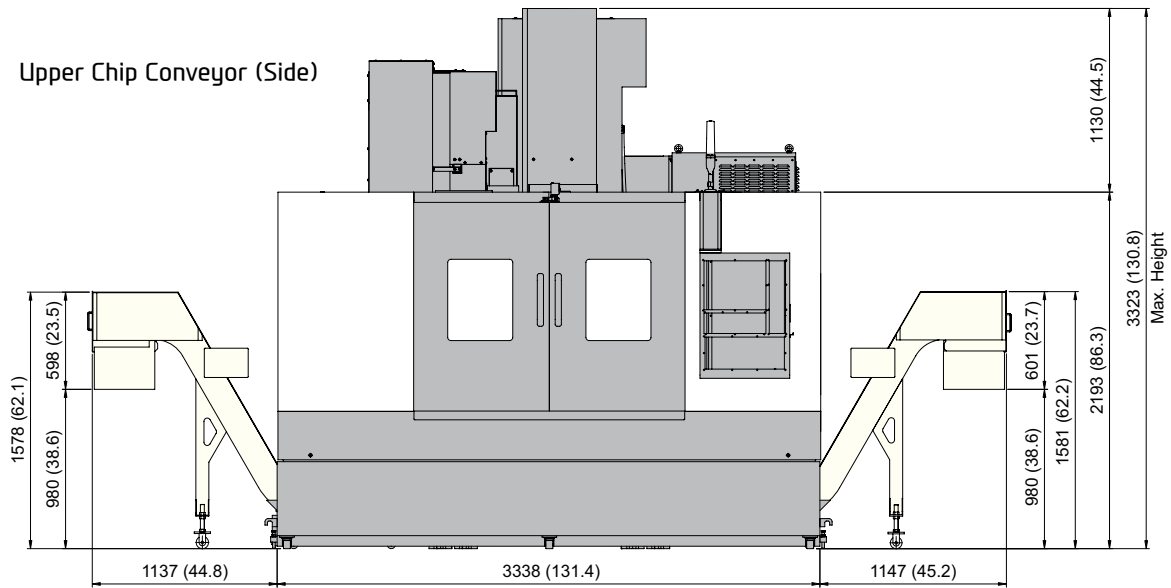

Upper Chip Conveyor (Rear)

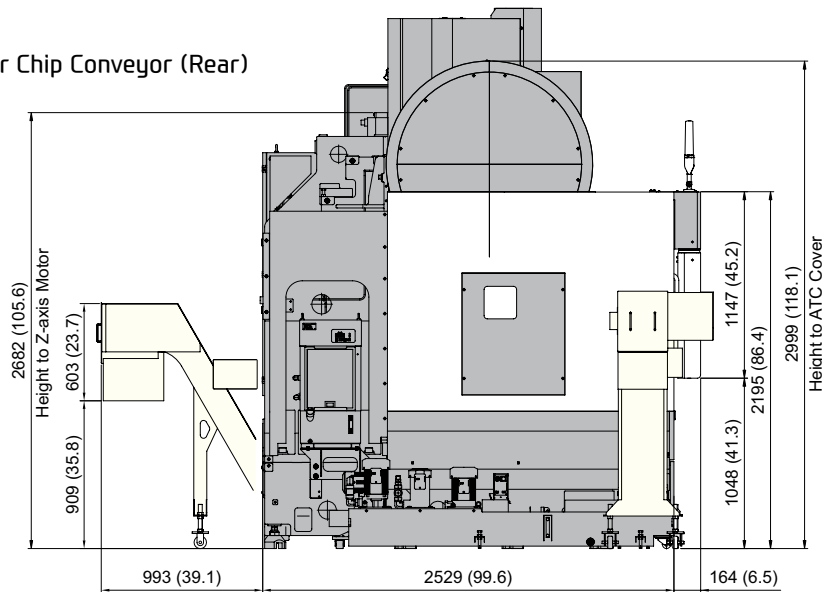

\*Level Block Height : Upper Chip Conveyor (Side) \_80mm (3.1"), Upper Chip Conveyor (Rear) \_200mm (7.9")

ITEM	Max. Height		24T ATC Cover		24T ATC Cover		Z-axis Motor	
	Std.	H/Column	Std.	H/Column	Std.	H/Column	Std.	H/Column
Upper/ Side	3,323 (130.8)	3,623 (142.6)	2,999 (118.1)	3,299 (129.9)	2,605 (102.6)	2,905 (114.4)	2,682 (105.6)	2,982 (117.4)
Upper/ Rear	3,443 (135.6)	3,743 (147.4)	3,119 (122.8)	3,419 (134.6)	2,725 (107.3)	3,025 (119.1)	2,802 (110.3)	3,102 (122.1)



# SPECIFICATIONS

## Tool Shank

unit : mm(in)

### BT50/BBT50, BIG PLUS

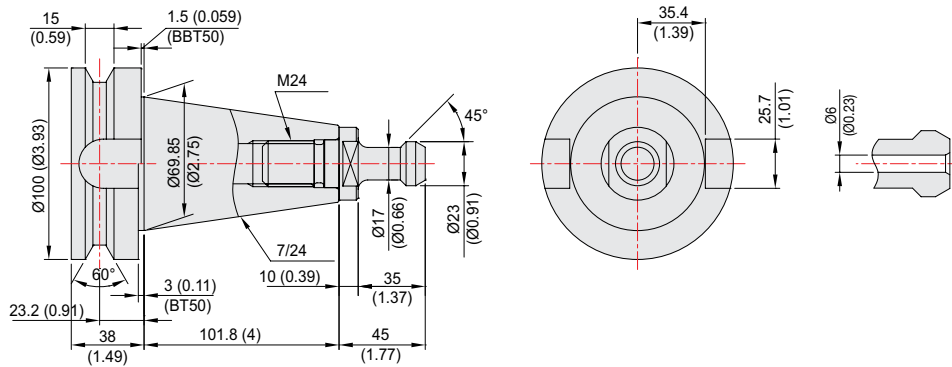

### HSK A-100

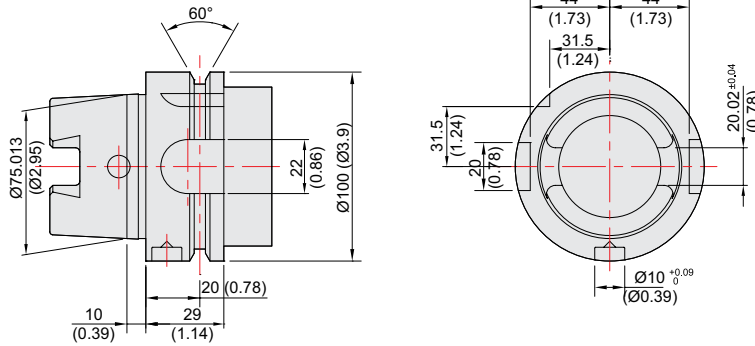

### CAT50/BCV50

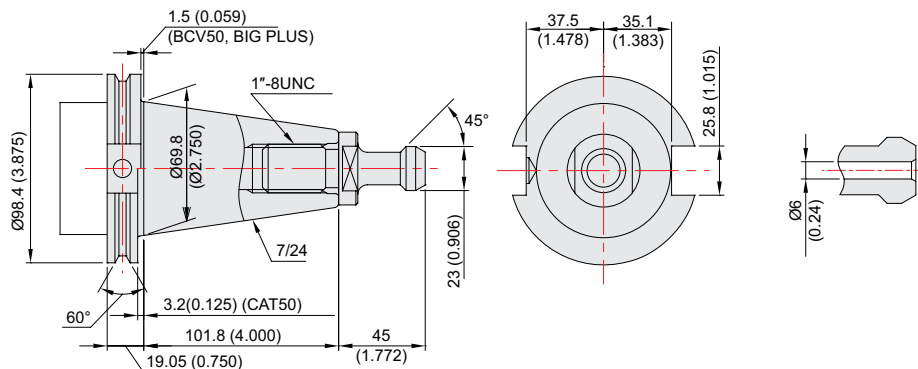





# SPECIFICATIONS

## Specifications

[ ] : Option

ITEM		KF4600 II	
TABLE	Table Size (L×W)	mm(in)	1,050×460 (41.3"×18.1")
	Maximum Load Capacity	kg(lb)	600 (1,323)
FEED	Travel (X/Y/Z)	mm(in)	900/460/520 (35.4"/18.1"/20.5")
	Rapid Traverse Rate (X/Y/Z)	m/min	36/36/30
	Distance from Table Top to SP. Nose	mm(in)	150 ~ 670 [870] (5.9" ~ 26.4" [34.3"])
	Distance from Column to SP. center	mm(in)	585 (23")
	Slide Type	-	ROLLER TYPE LM GUIDE
ATC	Number of Tools	ea	30 [40]
	Tool Shank	-	BBT40 [12K, 15K : HSK-A63]
	Max. Tool Dia. (W.T / W.O)	mm(in)	30T : Ø80 [40T : Ø76]/Ø125 (30T : Ø3.1" [40T : Ø3"]/Ø4.9")
	Max. Tool Length	mm(in)	300 (11.8")
	Max. Tool Weight	kg(lb)	8 (17.6)
	Tool Selection Method	-	RANDOM [FIXED]
	Tool Change Time	T-T	sec
C-C		sec	3.2
TANK CAPACITY	Coolant Tank	ℓ (gal)	340 (89.8)
	Lubricating Tank	ℓ (gal)	4 (1)
	Hydraulic Tank	ℓ (gal)	- (BOOSTER CYLINDER)
POWER SUPPLY	Air Consumption (0.5MPa)	ℓ /min(gal)	110 (29)
	Electric Power Supply	KVA	26
	Thickness of Power Cable	Sq	Over 25
	Voltage	V/Hz	220/60 (200/50)
MACHINE	Floor Space (L×W)	mm(in)	2,730×2,027 (107.5"×79.8")
	Height	mm(in)	3,028 (119.2")
	Weight	kg(lb)	5,500 (12,125)

## Spindle

[ ] : Option

ITEM	Speed r/min	Power (Max./Cont.) kW (HP)	Torque (Max./Cont.) N·m (lbf·ft)	Driving Method
HYUNDAI WIA FAPIIC - SMART PLUS	8,000	18.5/11 (25/15)	118/52.5 (87/38.7)	DIRECT
	[8,000 : High-torque]	15/11 (20/15)	286/143 (210.9/105.5)	
	[10,000]	18.5/11 (25/15)	118/52.5 (87/38.7)	
	[12,000]	18.5/11 (25/15)	118/52.5 (87/38.7)	
	[15,000]	18.5/11 (25/15)	118/52.5 (87/38.7)	
SIEMENS	[12,000]	16.2/8.5 (21.7/11.4)	119.7/63 (88.3/46.5)	
HEIDENHAIN	[12,000]	17/10 (22.8/13.4)	108.6/63.7 (80/47)	

# SPECIFICATIONS

## Specifications

[ ] : Option

ITEM		KF 5600 II	KF5600L II
TABLE	Table Size (L×W)	mm(in) 1,250×560 (49.2"×22")	1,500×560 (59.1"×22")
	Maximum Load Capacity	kg(lb)	1,000 (2,205)
FEED	Travel (X/Y/Z)	mm(in) 1,100/560/520 [635] (43.3"/22"/20.5" [25"])	1,300/560/520 (51.2"/22"/20.5")
	Rapid Traverse Rate (X/Y/Z)	m/min	36/36/30
	Distance from Table Top to SP. Nose	mm(in)	150 ~ 670 (5.9" ~ 26.4") [150 ~ 785 (5.9" ~ 30.9") [450 ~ 1,085 (17.7" ~ 42.7")]
	Distance from Column to SP. center	mm(in)	635 (23.4")
	Slide Type	-	ROLLER TYPE LM GUIDE
ATC	Number of Tools	ea	30 [40, 60] 30 [40]
	Tool Shank	-	BBT40 [12K, 15K : HSK-A63]
	Max. Tool Dia. (W.T / W.O)	mm(in)	30T : Ø80/Ø125 (30T : Ø3.1"/Ø4.9") [40, 60T : Ø76/Ø125 (Ø3"/Ø4.9")]
	Max. Tool Length	mm(in)	300 (11.8")
	Max. Tool Weight	kg(lb)	8 (17.6)
	Tool Selection Method	-	RANDOM [FIXED] RANDOM
	Tool Change Time	T-T	sec
C-C		sec	3.2 [Z-axis 635 mm (23.4") : 3.5] 3.5
TANK CAPACITY	Coolant Tank	ℓ (gal)	365 (96.4) 370 (97.7)
	Lubricating Tank	ℓ (gal)	4 (1)
	Hydraulic Tank	ℓ (gal)	- (BOOSTER CYLINDER)
POWER SUPPLY	Air Consumption (0.5MPa)	ℓ /min(gal)	110 (29)
	Electric Power Supply	kVA	26
	Thickness of Power Cable	Sq	Over 25
	Voltage	V/Hz	220/60 (200/50)
MACHINE	Floor Space (L×W)	mm(in)	2,830×2,176 (111.4"×85.7") 3,338×2,178 (131.4"×85.8")
	Height	mm(in)	3,028 (119.2") [3,443 (135.6")] 3,022 (119")
	Weight	kg(lb)	6,500 (14,330) [7,000 (15,432)] 6,700 (14,771)

## Spindle

[ ] : Option

ITEM	Speed r/min	Power (Max./Cont.) kW (HP)	Torque (Max./Cont.) N·m (lbf·ft)	Driving Method
HYUNDAI WIA FANUC - SMART PLUS	8,000	18.5/11 (25/15)	118/52.5 (87/38.7)	DIRECT
	[8,000 : High-torque]	15/11 (20/15)	286/143 (210.9/105.5)	
	[10,000]	18.5/11 (25/15)	118/52.5 (87/38.7)	
	[12,000]	18.5/11 (25/15)	118/52.5 (87/38.7)	
	[15,000]	18.5/11 (25/15)	118/52.5 (87/38.7)	
SIEMENS	[12,000]	16.2/8.5 (21.7/11.4)	119.7/63 (88.3/46.5)	
HEIDENHAIN	[12,000]	17/10 (22.8/13.4)	108.6/63.7 (80/47)	

# SPECIFICATIONS

## Specifications

[ ] : Option

ITEM		KF6700 II	
TABLE	Table Size (L×W)	mm(in)	1,500×670 (59"×26.4")
	Maximum Load Capacity	kg(lb)	1,300 (2,866)
FEED	Travel (X/Y/Z)	mm(in)	1,300/670/635 (51.2"/26.4"/25")
	Rapid Traverse Rate (X/Y/Z)	m/min	36/36/30
	Distance from Table Top to SP. Nose	mm(in)	150 ~ 785 (5.9" ~ 30.9") [450 ~ 1,085 (17.7" ~ 42.7")]
	Distance from Column to SP. center	mm(in)	690 (27.2")
	Slide Type	-	ROLLER TYPE LM GUIDE
ATC	Number of Tools	ea	30 [40, 60]
	Tool Shank	-	BBT40 [12K, 15K : HSK-A63]
	Max. Tool Dia. (W.T / W.O)	mm(in)	30T : Ø80/Ø125 (30T : Ø3.1"/Ø4.9") [40, 60T : Ø76/Ø125 (Ø3"/Ø4.9")]
	Max. Tool Length	mm(in)	300 (11.8")
	Max. Tool Weight	kg(lb)	8 (17.6)
	Tool Selection Method	-	RANDOM [FIXED]
	Tool Change Time	T-T	sec
C-C		sec	3.5
TANK CAPACITY	Coolant Tank	ℓ (gal)	365 (96.4)
	Lubricating Tank	ℓ (gal)	4 (1)
	Hydraulic Tank	ℓ (gal)	- (BOOSTER CYLINDER)
POWER SUPPLY	Air Consumption (0.5MPa)	ℓ /min(gal)	110 (29)
	Electric Power Supply	KVA	26
	Thickness of Power Cable	Sq	Over 25
	Voltage	V/Hz	220/60 (200/50)
MACHINE	Floor Space (L×W)	mm(in)	3,338×2,527 (131.4"×99.5")
	Height	mm(in)	3,196 (125.8")
	Weight	kg(lb)	7,600 (16,755)

## Spindle

[ ] : Option

ITEM	Speed r/min	Power (Max./Cont.) kW (HP)	Torque (Max./Cont.) N·m (lb·ft)	Driving Method
HYUNDAI WIA FAPIIC - SMART PLUS	8,000	18.5/15 (25/20)	118/71.6 (87/52.8)	DIRECT
	[8,000 : High-torque]	15/11 (20/15)	286/143 (210.9/105.5)	
	[10,000]	18.5/11 (25/15)	118/52.5 (87/38.7)	
	[12,000]	18.5/11 (25/15)	118/52.5 (87/38.7)	
	[15,000]	18.5/11 (25/15)	118/52.5 (87/38.7)	
SIEMENS	[12,000]	16.2/8.5 (21.7/11.4)	119.7/63 (88.3/46.5)	
HEIDENHAIN	[12,000]	17/10 (22.8/13.4)	108.6/63.7 (80/47)	

# SPECIFICATIONS

## Specifications

[ ] : Option

ITEM			KF5600/50 II	KF6700/50 II
TABLE	Table Size (L×W)	mm(in)	1,250×560 (49.2"×22")	1,500×670 (59"×26.4")
	Maximum Load Capacity	kg(lb)	1,000 (2,205)	1,300 (2,866)
SPINDLE	Spindle Taper	-	BBT50 [HSK-A100]	
	Spindle RPM	r/min	8,000	
	Spindle Power Output (Max./Cont.)	kW(HP)	22/11 (30/15)	
	Spindle Torque (Max./Cont.)	N·m(lbf·ft)	353.2/143 (260.5/105.5)	
	Spindle Driving Method	-	DIRECT	
FEED	Travel (X/Y/Z)	mm(in)	1,100/560/520 (43.3"/22"/20.5")	1,300/670/635 (51.2"/26.4"/25")
	Rapid Traverse Rate (X/Y/Z)	m/min	36/36/30	
	Distance from Table Top to SP. Nose	mm(in)	200~720 mm (7.9"~28.3")	200~835 mm (7.9"~32.9")
	Distance from Column to SP. center	mm(in)	635 (23.4")	690 (27.2")
	Slide Type	-	ROLLER TYPE LM GUIDE	
ATC	Number of Tools	ea	24	24 [30]
	Tool Shank	-	BBT50 [HSK-A100]	
	Max. Tool Dia. (W.T / W.O)	mm(in)	Ø125/Ø250 ( Ø4.9"/Ø9.8")	
	Max. Tool Length	mm(in)	350 (13.8")	
	Max. Tool Weight	kg(lb)	15 (33)	
	Tool Selection Method	-	RANDOM	
	Tool Change Time	T-T	sec	2.8
C-C		sec	5.5	
TANK CAPACITY	Coolant Tank	ℓ (gal)	350 (92.5)	370(97.7)
	Lubricating Tank	ℓ (gal)	4	
	Hydraulic Tank	ℓ (gal)	- (BOOSTER CYLINDER)	
POWER SUPPLY	Air Consumption (0.5MPa)	ℓ /min(gal)	110 (29)	
	Electric Power Supply	KVA	26	
	Thickness of Power Cable	Sq	Over 25	
	Voltage	V/Hz	220/60 (200/50)	
MACHINE	Floor Space (L×W)	mm(in)	2,830×2,176 (111.4"×85.7")	3,338×2,527 (131.4"×99.5")
	Height	mm(in)	3,137 (123.5")	3,336 (131.3")
	Weight	kg(lb)	7,300 (16,094)	9,000 (19,842)
NC	Controller	-	HYUNDAI WIA FANUC i Series - Smart Plus	

Specifications are subject to change without notice for improvement.

# CONTROLLER

## HYUNDAI WIA FANUC i Series – SMART PLUS

[ ] : Option ☆ Needed technical consultation

Controlled axis / Display / Accuracy Compensation	
Control axis	3 axis (X, Y, Z) [4 axis (X, Y, Z, A)] [5 axis (X, Y, Z, A, C)]
Simultaneously controlled axis	3 axis [Max. 4 axis]
Least setting Unit	X, Y, Z axis : 0.001 mm (0.0001 inch) B axis : 1 deg [0.001] deg
Least input increment	X, Y, Z axis : 0.001 mm (0.0001 inch) B axis : 1 deg [0.001] deg
Inch / Metric conversion	
High response vector control	
Interlock	All axis / Each axis
Machine lock	All axis
Backlash compensation	± 0 ~ 9999 pulses (Rapid traverse / Cutting feed)
Position switch	
LCD / MDI	15 inch LCD unit (with Touch Panel)
Feedback	Absolute motor feedback
Stored stroke check 1	Over travel
Stored stroke check 2, 3	
Stored pitch error compensation	
Operation	
Automatic operation (Memory)	
MDI operation	
DNC operation	Needed DNC software / CF card
Program restart	
Wrong operation prevention	
Program check function	Dry run, Program check, Z axis Machine lock Stored limit check before move
Single block	
Search function	Program Number / Sequence Number
Handle interruption	
Interpolation functions	
Nano interpolation	
Positioning	G00
Linear interpolation	G01
Circular interpolation	G02, G03
Exact stop mode	Single : G09, Continuous : G61
Dwell	G04, 0 ~ 9999.9999 sec
Skip	G31
Reference position return	1st reference, G28 / 2nd reference, G30 Ref. position check, G27
Single direction positioning	G60
Thread synchronous cutting	G33
Helical interpolation	Circular + Linear 2 axis (Max.)
Feed function / Acc. & Dec. control	
Manual feed	Rapid traverse Jog : 0~2,000mm/min (79 ipm) Manual handle : x1, x10, x100 pulses Reference position return
Cutting Feed command	Direct input F code
Feedrate override	0 ~ 200% (10% Unit)
Rapid traverse override	1%, 25%, 50%, 100%
Override cancel	
Feed per minute	G94
Feed per revolution	G95
Cylindrical interpolation	G07.1
Inverse time feed	G93
Look-ahead block	200 blocks (AI APC)
Program input	
Tape Code	EIA / ISO
Optional block skip	9 ea
Absolute / Incremental program	G90 / G91
Program stop / end	M00, M01 / M02, M30
Maximum command unit	± 999,999,999 mm (± 99,999,9999 inch)
Plane selection	X-Y, G17 / Z-X, G18 / Y-Z, G19
Workpiece coordinate system	G52, G53, 48 pairs (G54.1 P1 ~ 48)
Manual absolute	Fixed ON
Programmable data input	G10
Sub program call	10 folds nested
Custom macro	#100 ~ #199, #500 ~ #999
Programmable mirror image	G51.1, G50.1
G code preventing buffering	G4.1
Optional chamfering corner R	

Program input	
Polar coordinate command	G15, G16
Canned cycle	G73, G74, G76, G80 ~ G89
Scaling	G50, G51
Coordinate system rotation	G68, G69
Conversational Program	Smart Guide-i
Auxiliary function / Spindle speed function	
Level-up M Code	Multi / Bypass M code
Spindle speed function	S & 5 digit , Binary output
Spindle override	0% ~ 150% (10% Unit)
Spindle orientation	M19
Retraction for rigid tapping	
FSSB high speed rigid tapping	
Tool function / Tool compensation	
Tool function	Max. T8 digit
Tool life management	
Tool offset pairs	400 pairs
Tool nose / radius compensation	G40, G41, G42
Tool length offset	G43, G44, G49
Tool offset memory C	Tool geometry and wear (Cutter and tool length)
Tool length measurement	Z axis Input C
Editing function	
Part program storage size	5,120m (2MB)
No. of registerable programs	1,000 ea
Program protect	
Background editing	
Extended part program editing	Copy, move and change of NC program
Memory card program edit	
Data input / output & Interface	
I/O interface	CF card, USB memory Embedded Ethernet interface
Screen hard copy	
External message	
External key input	
External workpiece number search	
Automatic data backup	
Setting, display and diagnosis	
Self-diagnosis function	
History display & Operation	Alarm & Operator message & Operation
Run hour / Parts count display	
Maintenance information	
Actual cutting feedrate display	
Display of spindle speed / T code	
Graphic display	
Operating monitor screen	Spindle / Servo load etc.
Power consumption monitoring	Spindle & Servo
Spindle / Servo setting screen	
Multi language display	Support 24 languages
Display language switching	Selection of 5 optional Languages
LCD Screen Saver	Screen saver
Option	
Fast ethernet	Needed option board
Data server	Needed option board
Protection of data at 8 levels	
Additional Axis	
Manual handle feed	2/3 units #100 ~ #199, #500 ~ #999, #98000 ~ #98499
Add. Workpiece	Max. 300 pairs (G54.1 P1 ~ P300)
AICC II	400 blocks ☆

Figures in inch are converted from metric values.

The FANUC controller specifications are subject to change based on the policy of company CNC supplying.

# CONTROLLER

## SIEMENS 828D

[ ] : Option ☆ Needed technical consultation

### Controlled axis / Display / Accuracy Compensation

Control axis	3 axis (X, Y, Z) [4 axis (X, Y, Z, A)] [5 axis (X, Y, Z, A, C)]
Simultaneously controlled axis	Max. 4 axis
Least setting Unit	X, Y, Z axis : 0.001 mm (0.0001 inch) [A, C (B) axis : 1 deg [0.001] deg]
Least input increment	X, Y, Z축 : 0.001 mm (0.0001 inch) [A, C (B) axis : 1 deg [0.001] deg]
Inch / Metric changeover	G70 (inch) / G71 (metric)
Interlock	All axis / Each axis
Pitch error compensation	
Feedforward control	
LCD / MDI	10.4 inch color LCD [15 inch color LCD (With Touch panel)]
Keyboard	QWERTY full keyboard
Stored stroke check	Over travel

### Operation

Automatic operation	
MDI operation	
Program restart	
Program check function	Dry run / Program check / Machine lock
Single block	
Block search	Block search
Reposition	
Working area limit	Working area limitations

### Interpolation functions

Positioning	G00
Linear interpolation	G01
Circular interpolation	Circular Interpolation CW (G02) Circular Interpolation CCW (G03)
Exact position stop	Single block exact stop (G09) Exact stop G60 (G601, G602, G603)
Dwell	Dwell (G04)
Reference position return	Return to reference point Return to 2nd reference point
Helical interpolation	
Spline interpolation	Non-uniform rational B splines
Compressor for 3-axis machining (Improving machining quality)	Compacd /Compcurv (Cycle 832)

### Feed function / Acc. & Dec. control

Manual feed	Rapid traverse Jog Manual handle Reference position return
Cutting Feed command	Direct input F code
Feedrate override	0 ~ 200% (10% Unit)
Rapid traverse override	1%, 25%, 50%, 100%
Feed per minute	G94
Feed per revolution	G95
Look-ahead block	300 block 450 block : (SW28X Mold) [600 block]

### Program input

ISO correspondence	G291 (ISO)/G290 (ISO G Code system-A)
Optional block skip	2
Program stop / end	M00, M01 / M02, M30
Maximum command unit	± 999,999,999 mm, ± 99,999,999 inch
Plane selection	X-Y : G17, X-Z : G18, Y-Z : G19 G54 ~ G57, G505~G549
Workpiece coordinate system	G500 (Basic frame - settable zero offset) G53 (Work offset non modal) G153 (basic frame non modal)
Sub program call	11 folds nested
G code preventing buffering	STOPRE
Drilling/Milling cycle	Programing (Cycle 82, 83, 84, 840)
User cycle	

### Auxiliary function / Spindle speed function

Auxiliary function	M Code 4 digit
Spindle speed function	S Code 5 digit
Spindle override	0% ~ 150% (10% Unit)
Spindle orientation	SPOS
Rigid tapping	
Automatic mode Interchange	Spindle / Axis mode
Constant surface speed control	G96, G97
Spindle speed limitation	LIMS

### Tool function / Tool compensation

Tool function	Tool number & Tool name Tool : T + Offset : D
Tool life management	
Tools in tool list	256 ea 768 ea : (SW28X Mold)
Cutting Edges in tool list	512 ea 1,536 ea : (SW28X Mold)
Tool radius compensation	ISO (G40, G41, G42)
Tool length offset	
Geometry / Wear compensation	
Measurement of tool length	
Tool management function	

### Editing function

Part program storage size	5MB 10MB : (SW28X Mold)
No. of registerable programs	750 ea
External Storage devices	Local network, Server, USB, Flash drive
Background editing	
Extended part program editing	Copy, move and change of NC program
Memory card program edit	

### Data input / output & Interface

I/O interface	CF card interface (ONLY 10.4") USB memory interface Embedded Ethernet memory interface
---------------	--

### Screenshot

### Setting, display and diagnosis

Self-diagnosis function	
History display & Operation	Alarm & Operator message & Operation
Run hour / Parts count display	
Maintenance information	
Actual cutting feedrate display	
Display of spindle speed / T code	
Graphic display	
Operating monitor screen	Spindle / Servo load etc. Support 9 languages Chinese (Simplified/Traditional), English, French, German, Italian, Korean, Portuguese, Spanish [☆ 22 Support languages : Inquiry need]
Multi language display	
LCD Screen Saver	Screen saver & Motion sensing

### Option

Additional optional block skip	10 ea
Additional axis control	
Contour handwheel	
3D simulation	
Real time simulation	
ShopMill	Machining step programming for milling

# MOVEMENT FOR BETTER TOMORROW



## ECO FRIENDLY

Minimizing Environmental Impact and Maintaining Sustainable Ecology

**01**

**Achieve  
carbon  
neutrality**

- Develop Net-zero Roadmap
- Heighten carbon emissions management
- Achieve carbon neutrality goals

**02**

**Boost  
resource  
circulation**

- Detail plans to reduce environmental impact
- Gradually reduce pollutant emissions
- Build eco-friendly supply chain

**03**

**Establish  
environmental  
management  
framework**

- Set up environmental management process
- Assess business impact of climate change risks

# HYUNDAI WIA ECO SYSTEM

## MQL (Minimal Quantity Lubrication)

The goal of this system is to spray only the amount of lubricant required to prevent heat and chip build up at the cutting tool or work piece face.

### Example of Machining Center Application

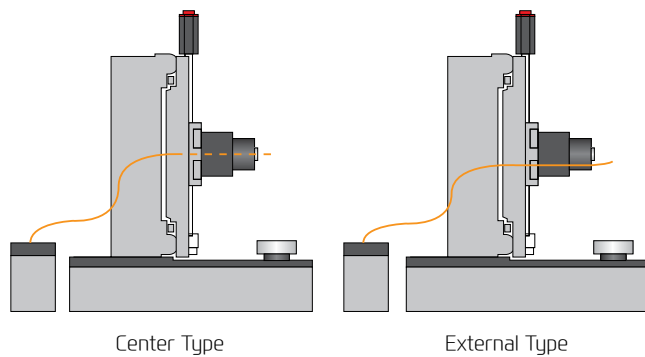

### Example of Etc.

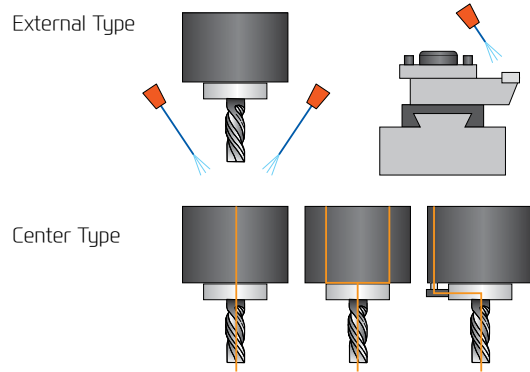

Oil Skimmer

An oil skimmer can increase coolant and tool life by removing tramp oil contaminants.



Mist Collector

Mist Collector reduces the amount of smoke and oil mist in the air. This helps build a safe and comfortable working environment and improve durability.

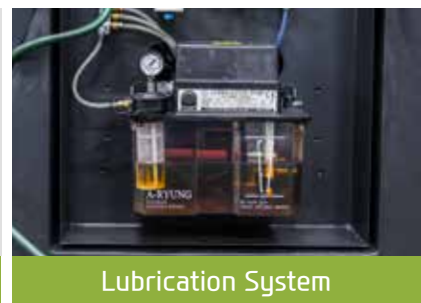

Lubrication System

By applying lubricant only when the machines axis are moving lubrication consumption is reduced by compared to standard systems.

# HYUNDAI WIA ENERGY SAVING

## HW-ESS (HYUNDAI WIA Energy Saving System)

HYUNDAI WIA Machine tool provides the optimum power saving function that can easily save energy with an intuitive user interface.



1. **Machine-ready power saving function** : Put all servo motors and other motors into sleep mode when no control or operation is done for a set time
2. **Work light auto-off function** : The work light is turned off automatically when no control or operation is done for a set time
3. **Chip conveyor auto power saving** : Operation/non operation time (timer) can be set to save energy
4. **Auto Power-off** : Auto power off after ending the an operation after a period of time
5. **Eco function** : Machine ready sleep mode can be activated/de-activated from the controller panel
6. **Power consumption monitor** : Real time power consumption can be monitored through the OP screen



YouTube HYUNDAI WIA MT  
[www.youtube.com/HYUNDAIWIAMT](http://www.youtube.com/HYUNDAIWIAMT)

## CREATING VALUE IN SEAMLESS MOBILITY

With its top-quality HYUNDAI WIA machine tool creates a new and better world.



<http://machine.hyundai-wia.com>  
HYUNDAI WIA Machine Tools  
Global Links

### HEADQUARTER

R&D Center/Factory 153, Jeongdong-ro, Seongsan-gu, Changwon-si, Gyeongsangnam-do, Korea TEL : +82 55 280 9114 FAX : +82 55 282 9114

Overseas Sales Team /R&D Center 37, Cheoldobangmulgwan-ro, Uiwang-si, Gyeonggi-do, Korea TEL : +82 31 8090 2539

### OVERSEAS OFFICES

HYUNDAI WIA Machine America corp. 450 Commerce Blvd, Carlstadt, NJ 07072, USA TEL : +1-201-987-7298

HYUNDAI WIA Europe GmbH Alexander-Fleming-Ring 57, 65428 Rüsselsheim Germany TEL : +49-0-6142-9256-0

HYUNDAI WIA Machine Tools China 2-3F, Bldg6, No.1535 Hongmei Road, Xuhui District, Shanghai, China TEL : +86-21-6427-9885

Russia Branch Office 141006, Russia, Moscow Region, Mytishchi, Volkovskoe sh. 5A, b. 1, office 306 TEL : +7-495-502-7023

India Branch Office #4/169, 1st Floor, LOTTE BLDG, Rajiv Gandhi Salai, (OMR), Kandanchavadi, Chennai - 600096, Tamilnadu, India TEL : +91-76-0490-3348